

Introduction

This document details the instruction set for the dsPIC33A family of DSC devices. This is intended to guide development in the native assembly language for optimization and direct control over instruction execution. Assembly code can be used to simplify and accelerate time-sensitive applications including embedded control loops and data processing. More information about these devices and products, along with corresponding technical documentation, is available on the Microchip website (www.microchip.com).

This manual is a software developer's reference that describes the instruction set in detail and also provides general information to assist the development of software for the dsPIC33A device families.

This manual does not include detailed information about the core, peripherals, system integration or device-specific information. The user should refer to the device specific data sheet for information on the core, peripherals and system integration. The data sheet will also include information on:

- Device memory map
- Device pinout and packaging details
- Device electrical specifications
- List of peripherals included on the device

Code examples/snippets are given throughout this manual. These examples are valid for the devices from the dsPIC33A families.

Development Support

Microchip offers a wide range of development tools that allow users to efficiently develop and debug application code. Microchip's development tools can be broken down into four categories:

- Code Generation
- Hardware/Software Debug
- Device Programmer
- Product Evaluation Boards

Information about the latest tools, product briefs and user guides can be obtained from the Microchip website (www.microchip.com) or from a local Microchip sales office.

Microchip offers additional resources to speed up the development cycle. These include:

- Application Notes
- Reference Designs
- Microchip Website
- Local Sales Offices with Field Application Support
- Corporate Support Line

The Microchip website also lists other sites that may serve as useful references.

Style and Symbol Conventions

Throughout this document, certain style and font format conventions are used. [Table 1](#) provides a description of the conventions used in this document.

Table 1. Document Conventions

Symbol or Term	Description
set	To force a bit/register to a value of logic '1'.
clear	To force a bit/register to a value of logic '0'.
Reset	<ol style="list-style-type: none">1. To force a register/bit to its default state.2. A condition in which the device places itself after a device reset occurs. Some bits will be forced to '0' (such as Interrupt Enable bits), while others will be forced to '1' (such as the I/O Data Direction bits).
0xnnnn	Designates the number 'nnnn' in the hexadecimal number system. These conventions are used in the code examples. For example, 0x013F or 0xA800.
: (colon)	Used to specify a range or the concatenation of registers/bits/pins. One example is ACCAU:ACCAH:ACCAL, which is the concatenation of three registers to form the 72-bit Accumulator. Concatenation order (left-right) usually specifies a positional relationship (MSb to LSb, higher to lower).
[]	Specifies bit locations in a particular register. One example is SR[7:5] (or IPL[2:0]), which specifies the register and associated bits or bit locations.
LSb, MSb	Indicates the Least Significant or Most Significant bit in a field.
LSB, MSB	Indicates the Least/Most Significant Byte in a field of bits.
lsw, msw	Indicates the least/most significant word in a field of bits
Courier New Font	Used for code examples, binary numbers and for instruction mnemonics in the text.
Times New Roman Font, <i>Italic</i>	Used for equations and variables.
Times New Roman Font, <i>Bold Italic</i>	Used in explanatory text for items called out from a figure, equation or example.
Note:	A Note presents information that we want to re-emphasize, either to help the user avoid a common pitfall or to make the user aware of operating differences between some device family members. A note can be in a box, or when used in a table or figure, it is located at the bottom of the table or figure.

Instruction Set Symbols

The summary tables in [Instruction Set Overview](#) and [Instruction Set Summary Tables](#), and the instruction descriptions in [Instruction Descriptions](#) utilize the symbols shown in [Table 2](#).

Table 2. Symbols Used in Instruction Summary Tables and Descriptions

Symbol ⁽¹⁾	Description
{ }	Optional field or operation
[text]	The location addressed by text
(text)	The contents of text
#text	The literal defined by text
{label: }	Optional label name
[n:m]	Register bit field
.l	32-bit Long Word mode selection
.b	8-bit Byte mode selection
.sl	24-bit (literal) Word mode selection
.V	Destination data value select (MAXABW, MINABW and FLIMW)
.w	16-bit Word mode selection (default)
AWB	Accumulator write back destination address register
bit3	3-bit bit selection field (used in byte addressed instructions) (0:7)
bit4	4-bit bit selection field (used in word addressed instructions) (0:15)
C, N, OV, Z	ALU status bits: Carry, Digit Carry, Negative, Overflow, Zero
d	File register destination (W0, none)
Expr	Absolute address, label or expression (resolved by the linker)
f	File register address (0x0000:0xFFFF) or (0x00000:0xFFFFF) (addressable space varies depending upon instruction class)
Fd ⁽²⁾	One of 32 FPU destination data registers (F0:F31) (Register Direct)
Fs ⁽²⁾	One of 32 FPU source data registers (F0:F31) (Register Direct)
FSR, FSRH, FCR, FEAR ⁽²⁾	FPU special (control & status) coprocessor registers (Register Direct)
label	Translates to a literal representing the location of the label name
lit1	1-bit unsigned literal (0:1)
lit3	3-bit unsigned literal (0:7)
lit5	5-bit unsigned literal (0:31)
lit6	6-bit unsigned literal (0:63)
lit8	8-bit unsigned literal (0:255)
lit16	16-bit unsigned literal (0:65535)
lit24	24-bit unsigned literal (0:1677215; LSB must be 0 if an address)
lit32	32-bit unsigned literal (0:4294967295)
none	Field does not require an entry and may be blank
OA, OB, SA, SB	DSC status bits: ACCA Overflow, ACCB Overflow, ACCA Saturate, ACCB Saturate
PC	Program Counter
Wd	Destination Working register
Rnd	Instruction rounding mode [E, Z, P, N]
Ws	Source Working register
slit6	Signed 6-bit literal (-32:31)
slit7	Signed 7-bit literal (-64:63)
slit8	Signed 8-bit literal (-128:127)
slit20	Signed 20-bit literal (-524288:524287)

Table 2. Symbols Used in Instruction Summary Tables and Descriptions (continued)

Symbol ⁽¹⁾	Description
SR	Status Register
$\text{text1} \in \{\text{text2}, \text{text3}, \dots\}$	text1 must be in the set of text2, text3, ...
v	Selects MULxxx operand data types
Wb	Base Working register
Wd	Destination Working register
Wm	One of 16 Working registers (W0:W15)
Wn	Both source and destination Working register (W0:W15)
Wnd	One of 16 destination Working registers
Wns	One of 16 source Working registers
Wm * Wm	Multiplicand and Multiplier Working register for Square instructions
Wm * Wn	Multiplicand and Multiplier W register for DSP instructions
Ws	Source Working register
Wx	X data space fetch address register for DSP instructions
Wy	Y data space fetch address register for DSP instructions

Notes:

1. The range of each symbol is instruction-dependent. Refer to [Instruction Descriptions](#) for the specific instruction range.
2. Only applicable when the FPU coprocessor is present.

Table of Contents

Introduction.....	1
Development Support.....	2
Style and Symbol Conventions.....	2
Instruction Set Symbols.....	3
1. dsPIC33A Core Architecture Overview.....	7
1.1. Features Specific to the dsPIC33A Core.....	7
1.2. Floating Point Unit (FPU) Overview.....	8
1.3. Programmer's Model.....	12
1.4. Working Register Array.....	13
1.5. Software Stack Frame Pointer.....	13
1.6. Software Stack Pointer.....	13
1.7. Stack Pointer Limit Register (SPLIM).....	13
1.8. Accumulator A and Accumulator B.....	13
1.9. Program Counter.....	13
1.10. RCOUNT Register.....	13
1.11. STATUS Register.....	13
1.12. Core Control Register.....	15
1.13. CPU STATUS Register.....	16
1.14. Core Control Register.....	19
2. Instruction Set Overview.....	21
2.1. Multicycle Instructions.....	21
2.2. Multiword Instructions.....	22
2.3. Instruction Set Summary Tables.....	22
3. Instruction Set Details.....	33
3.1. Data Addressing Modes.....	33
3.2. Data Addressing Mode Tree.....	40
3.3. Program Addressing Modes.....	40
3.4. Instruction Stalls.....	41
3.5. Byte Operations.....	42
3.6. Word Move Operations.....	44
3.7. Using 16-Bit Literal Operands.....	47
3.8. Bit Field Insert/Extract Instructions.....	47
3.9. Software Stack Pointer and Frame Pointer.....	48
3.10. Conditional Branch Instructions.....	52
3.11. Z Status Bit.....	54
3.12. DSP Data Formats.....	54
3.13. Accumulator Usage.....	56
3.14. Accumulator Access.....	57
3.15. DSP MAC Instructions.....	58
3.16. DSP Accumulator Instructions.....	60
3.17. Scaling Data with the FBCL Instruction.....	61
3.18. Data Range Limit Instructions.....	62
3.19. Normalizing the Accumulator with the NORM Instruction.....	62

4.	Instruction Descriptions.....	63
4.1.	Instruction Symbols.....	63
4.2.	Instruction Encoding Field Descriptors Introduction.....	63
4.3.	Instruction Description Example.....	67
4.4.	Instruction Descriptions (A to BZ).....	68
4.5.	Instruction Descriptions (C to DTB).....	146
4.6.	Instruction Descriptions (E to MULUU).....	175
4.7.	Instruction Descriptions (N to XORWF).....	254
4.8.	FPU Instruction Encoding and Opcode Field Description	333
4.9.	Floating-Point Instruction Description.....	334
5.	Built-In Functions.....	371
5.1.	Introduction.....	371
5.2.	Built-In Functions List.....	372
6.	Reference.....	389
6.1.	Instruction Bit Map.....	389
6.2.	Instruction Set Summary Table.....	389
7.	Revision History.....	408
	Microchip Information.....	409
	Trademarks.....	409
	Legal Notice.....	409
	Microchip Devices Code Protection Feature.....	409

1. dsPIC33A Core Architecture Overview

This section provides an overview of the features and capabilities of the dsPIC33A family of devices.

1.1. Features Specific to the dsPIC33A Core

The dsPIC33A devices are 32-bit (data) modified Harvard architecture, with a 5-stage instruction pipeline and a single-phase clock design, featuring an enhanced instructions set. The core has a 32-bit instruction word with an 8-bit opcode field. The Program Counter (PC) is 24 bits wide and addresses up to 4M x 32 bits of user program memory space. An instruction prefetch mechanism is used to help maintain throughput and provides predictable execution. The majority of instructions execute in a single cycle.

1.1.1. Registers

The dsPIC33A devices have sixteen 32-bit Working registers. Each of the Working registers can act as a data, address or offset register. The 16th Working register (W15) operates as a Software Stack Pointer (SSP) for interrupts and function calls.

1.1.2. Instruction Set

The instruction set is almost identical for the 16-bit MCU and DSC architectures. The instruction set includes many addressing modes and was designed for optimum C compiler efficiency.

1.1.3. Addressing Modes

The core supports Inherent (no operand), Relative, Literal, Memory Direct, Register Direct, Register Indirect and Register Offset Addressing modes. Each instruction is associated with a predefined addressing mode group, depending upon its functional requirements. As many as seven addressing modes are supported for each instruction.

For most instructions, the CPU is capable of executing a data (or program data) memory read, a Working register (data) read, a data memory write and a program (instruction) memory read per instruction cycle. As a result, 3-operand instructions can be supported, allowing $A + B = C$ operations to be executed in a single cycle.

1.1.4. Arithmetic and Logic Unit

A high-speed, 33-bit by 33-bit multiplier is included to significantly enhance the core's arithmetic capability and throughput. The multiplier supports signed and unsigned, as well as 32-bit by 32-bit, or 16-bit by 16-bit integer multiplication. All multiply instructions execute in a single cycle.

The Arithmetic Logic Unit (ALU) is enhanced with integer divide assist hardware that supports an iterative non-restoring divide algorithm. It operates in conjunction with the REPEAT instruction looping mechanism and a selection of iterative divide instructions to support 32/32-bit, 32/16-bit, and 16/16-bit signed and unsigned, integer and fractional divide operations.

1.1.5. Exception Processing

The dsPIC33A devices have a vectored exception scheme with support for up to eight sources of non-maskable traps and up to 502 interrupt sources. Each interrupt source can be assigned to one of seven priority levels.

1.1.6. MCU Multiplications With 64-Bit Result

32x32-bit MUL instructions include an option to store the product in a single 32-bit Working register rather than a pair of registers. This feature helps free up a register for other purposes in cases where the numbers being multiplied are small in magnitude and therefore expected to provide a 16-bit result. See the individual MUL instruction descriptions in [Instruction Descriptions](#) for more details.

1.1.7. DSP Context Switch Support

DSP Overflow and Saturation Status bits are writable. This allows the state of the DSP engine to be efficiently saved and restored while switching between DSP tasks. See [DSP ALU Status Bits](#) for more details on DSP Status bits. There are also seven additional sets of CORCON, DSP Accumulators A and B for fast context switching; each set is inherently assigned to a respective IPL.

Any writes to CORCON at context-0 will be replicated across all DSP-related bits within CORCON registers mapped to contexts 1–7, until a write is made to the CORCON within one of the contexts 1–7 for the first time. A reset will re-enable CORCON write replication.

For instance, if the CPU IPL changes to IPL3 and the user writes to the associated CORCON (that is, CORCON of context-3), any subsequent writes to CORCON from context-0 will no longer affect CORCON from context-3. This applies to any CORCON register that was written from within its context. In contrast, further writes to CORCON at context-0 will continue to replicate over all CORCON registers that haven't been written to from within their contexts.

The code can assume that the DSP CORCON state remains consistent across all CPU register contexts following a reset and background initialization. In many applications, all DSP functions will utilize the same DSP engine configuration, making consistent initialization beneficial by eliminating the need to set up CORCON for each context individually. However, if a specific context requires a unique DSP engine configuration, it can initialize it as needed and subsequently prevent any background changes to CORCON from affecting the local CORCON configuration.

1.1.8. DSP Instruction Class

The DSP class of instructions are seamlessly integrated into the architecture and will execute from a single execution unit.

1.1.9. Data Space Addressing

The data space is split into two blocks, referred to as X and Y data memory. Each memory block has its own independent Address Generation Unit (AGU). The MCU class of instructions operates solely through the X memory AGU, which accesses the entire memory map as one linear data space. The DSP dual source class of instructions operates through the X and Y AGUs, which splits the data address space into two parts. The X and Y data space boundary is arbitrary and device-specific.

1.1.10. Modulo and Bit-Reversed Addressing

Overhead-free circular buffers (Modulo Addressing) are supported in both X and Y address spaces. The Modulo Addressing removes the software boundary checking overhead for DSP algorithms. Furthermore, the X AGU Circular Addressing can be used with any of the MCU class of instructions. The X AGU also supports Bit-Reversed Addressing to greatly simplify input or output data reordering for radix-2 FFT algorithms.

1.1.11. DSP Engine

The DSP engine features a high-speed 33-bit by 33-bit multiplier, a 72-bit ALU, two 72-bit saturating accumulators and a 72-bit bidirectional barrel shifter. The barrel shifter is capable of shifting a 72-bit value up to 32 bits right or up to 32 bits left in a single cycle. The DSP instructions operate seamlessly with all other instructions and have been designed for optimal real-time performance. The MAC instruction and other associated instructions can concurrently fetch two data operands from memory while multiplying two Working registers. This requires that the data space be split for these instructions and linear for all others. This is achieved in a transparent and flexible manner through dedicating certain Working registers to each address space.

1.2. Floating Point Unit (FPU) Overview

The IEEE standard for floating-point arithmetic (IEEE 754-2008) specifies the floating-point data formats as shown in [Figure 1-1](#), which are comprised of a Sign bit, an exponent value and a (fractional) mantissa value. The dsPIC33A Floating-Point Unit (FPU) supports both single precision (32-bit, SP) and double precision (64-bit, DP) operations for most instructions.

To avoid the need for another Sign bit in the exponent, the IEEE floating-point format exponent is biased by 127 (SP) or 1023 (DP). Consequently, for any datum, the required IEEE exponent value = datum exponent + bias. In addition, the '1' to the left of the Most Significant bit (MSb) of the mantissa is implied for all numbers except subnormal numbers and is consequently referred to as the leading bit convention or "hidden bit." Therefore, the mantissa is a fractional value with an implied integer value of [1].

Figure 1-1. IEEE Floating-Point Data Formats and Single Precision Example

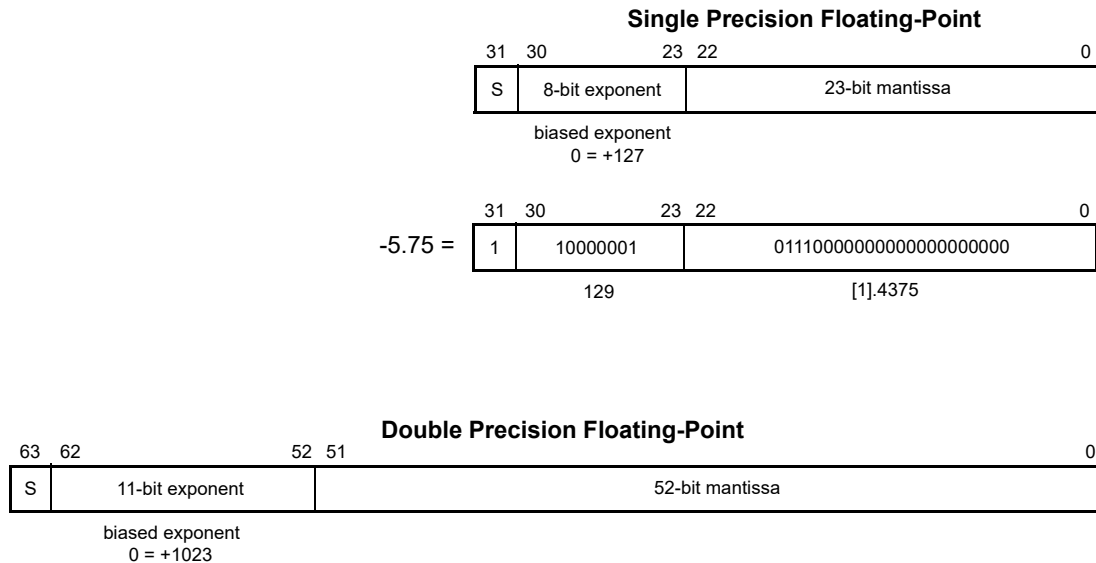

$$(-1)^S \times [1].m_{\text{base}2} \times 2^{(e-\text{bias})}$$

where:

- 'S' indicates the sign of the number (same values as a signed integer value)
- 'e' represents the exponent value
- 'm' represents the fractional mantissa value
- 'bias' is 127 (SP) or 1023 (DP)

For example, $-5.75 = -(1.4375 \times 2^2)$. In IEEE SP format, this would be represented as:

$$(-1)^1 \times [1].4375 \times 2^{(129-127)}$$

or (as shown in [Figure 1-1](#)):

$$S = 1, \text{ exponent} = 129_{10}, \text{ mantissa} = [1].4375_{10}$$

or: 0xC0B8 0000

1.2.1. Floating-Point Unit Registers

The dsPIC33A Floating-Point Unit (FPU) provides a large set of Working registers (F-regs):

- 32 x 32-bit (Single Precision, F0 ... F31) or
- 16 x 64-bit (Double Precision, F0, F2 ... F28, F30) or
- A mix of the two sizes aligned as shown in [Figure 1-2](#).

In addition to the F-regs, status (FSR) and control (FCR) registers are also supported as shown in [Figure 1-2](#):

- FSR (FPU Status Register, 32-bit): Holds the status of retired floating-point instructions:

- FSR[6:0]: Instruction "most-recent" exception status
- FSR[14:8]: Instruction "sticky" exception status
- FSR[19:16]: CPS/CPQ instruction status
- FSR[28:24]: FTST instruction status
- FCR (FPU Control Register, 16-bit):
 - FCR[6:0]: Exception mask control
 - FCR[9:8]: Rounding mode control
 - FCR[10]: Subnormal result "Flush to Zero" (FTZ) control
 - FCR[11]: Subnormal operand "Subnormals are Zeros" (SAZ) control
- FEAR: (FPU Exception Address Capture Register, 24-bit):
 - Holds the address of the first instruction encountered that causes an exception. All subsequent instructions in the FPU pipeline that subsequently retire will not affect the FEAR, even if they too generate exceptions.

Figure 1-2. FPU Programmer's Model

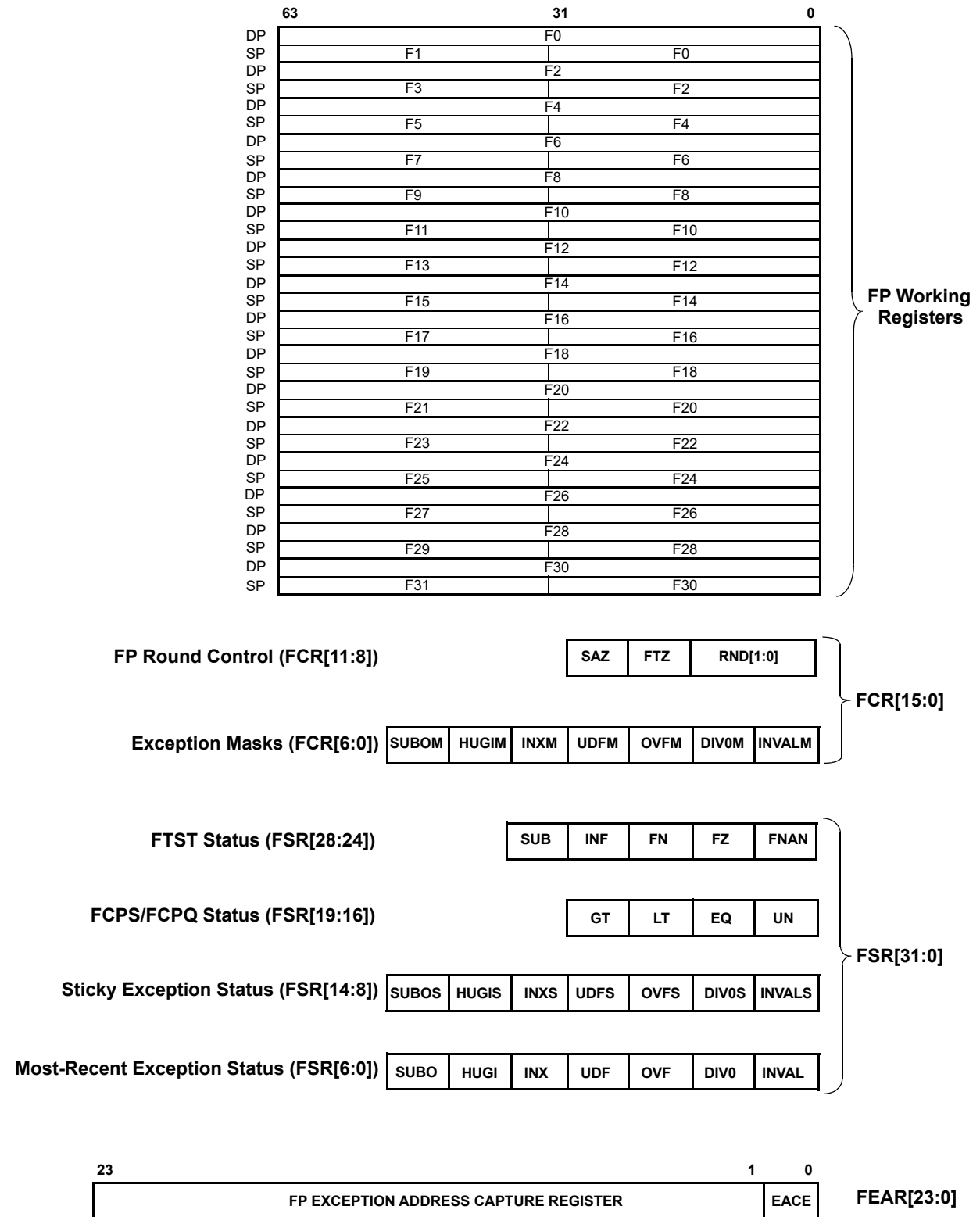

Note: Only a single register context shown.

1.3. Programmer's Model

Figure 1-3 shows the programmer's model diagrams for the dsPIC33A family of devices.

Figure 1-3. dsPIC33A Programmer's Model

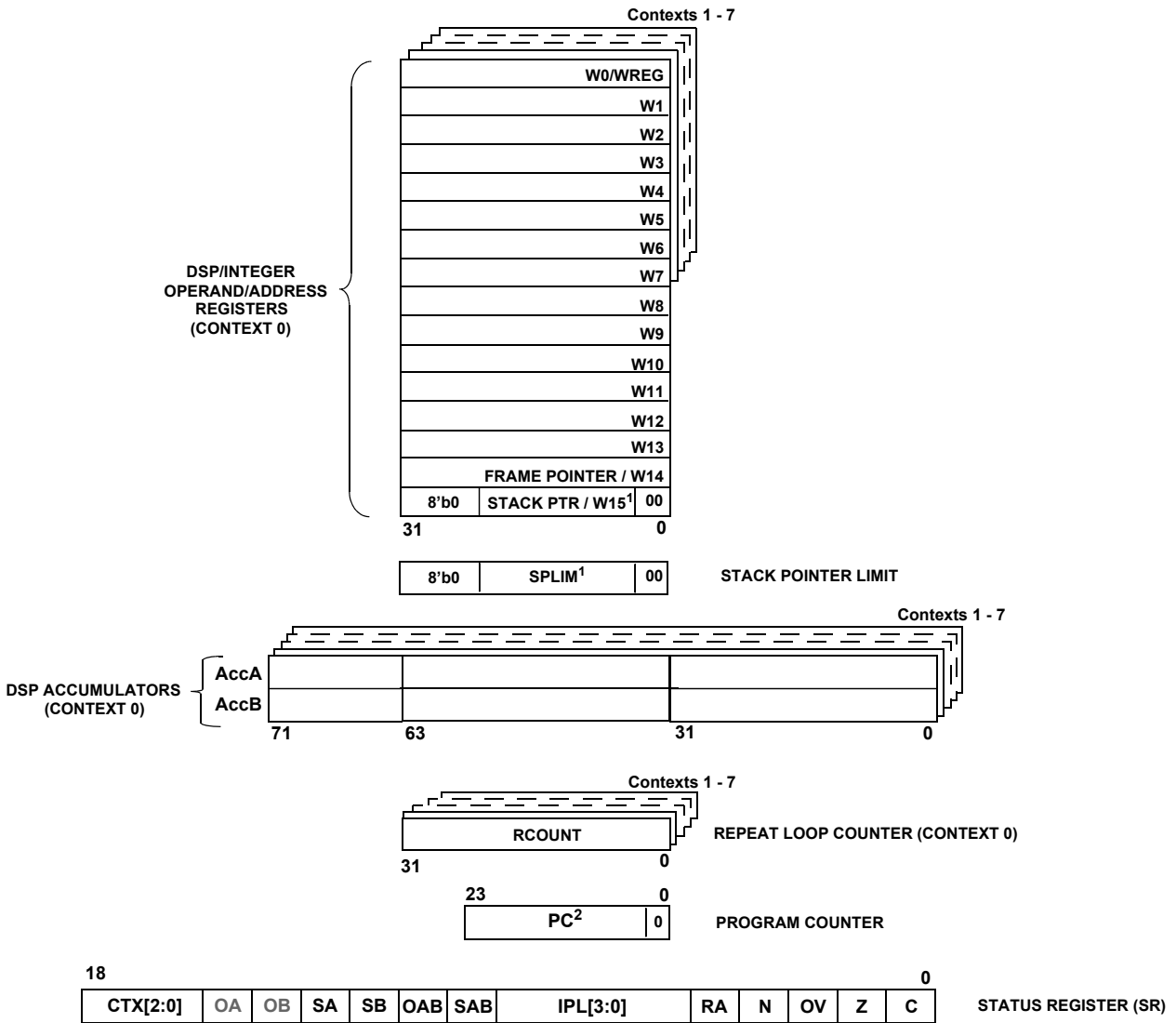

Notes:

1. W15[1:0] and SPLIM[1:0] always = 0b00.
2. PC[0] always = 0b0.

Table 1-1. Programmer's Model Register Descriptions

Register	Description
CORCON	CPU Core Configuration register
PC	24-Bit Program Counter
RCOUNT	REPEAT Loop Counter register
SPLIM	Stack Pointer Limit Value register
SR	ALU and DSP Engine STATUS Register
W0-W15	Working register array
ACCA, ACCB	72-Bit DSP Accumulators

1.4. Working Register Array

The 16 Working (W) registers can function as data, address or offset registers. The function of a W register is determined by the instruction that accesses it.

Byte instructions, which target the Working register array, only affect the Least Significant Byte (LSB) of the target register.

1.5. Software Stack Frame Pointer

A frame is a user-defined section of memory in the stack, used by a function to allocate memory for local variables. W14 has been assigned for use as a Stack Frame Pointer with the link (`LNK`) and unlink (`ULNK`) instructions. However, if a Stack Frame Pointer and the `LNK` and `ULNK` instructions are not used, W14 can be used by any instruction in the same manner as all other W registers. See [Software Stack Frame Pointer](#) for detailed information about the Frame Pointer.

1.6. Software Stack Pointer

W15 serves as a dedicated Software Stack Pointer and will be automatically modified by function calls, exception processing and returns. However, W15 can be referenced by any instruction in the same manner as all other W registers. This simplifies reading, writing and manipulating the Stack Pointer. Refer to [Software Stack Pointer](#) for detailed information about the Stack Pointer.

1.7. Stack Pointer Limit Register (SPLIM)

The SPLIM is a 32-bit register associated with the Stack Pointer. It is used to prevent the Stack Pointer from overflowing and accessing memory beyond the user allocated region of stack memory. Refer to [Stack Pointer Overflow](#) for detailed information about the SPLIM.

1.8. Accumulator A and Accumulator B

Accumulator A (ACCA) and Accumulator B (ACCB) are 72-bit wide registers utilized by DSP instructions to perform mathematical and shifting operations.

Accumulator A and Accumulator B can also be used as destination registers in MCU `MUL.xx` instructions. This helps reduce the execution time of extended precision arithmetic operations.

Refer to [Figure 3-13](#) for details on using ACCA and ACCB.

1.9. Program Counter

The Program Counter (PC) is 24 bits wide. Instructions are addressed in the 4M x 32-bit user program memory space by `PC[23:1]`, where `PC[0]` is always set to '0' to maintain instruction word alignment and provide compatibility with Data Space Addressing. This means that during normal instruction execution, the PC increments by two, four or eight during sequential 16-bit, 32-bit or 64-bit instruction execution, respectively.

1.10. RCOUNT Register

The 32-bit RCOUNT register contains the loop counter for the `REPEAT` instruction. When a `REPEAT` instruction is executed, RCOUNT is loaded with the repeat count of the instruction, either "lit20" for the "`REPEAT #lit20`" instruction, "lit5" for the "`REPEAT #lit5`" instruction or Wn register for the "`REPEAT Wn`" instruction. The `REPEAT` loop will be executed `RCOUNT + 1` time.

Note: If a `REPEAT` loop is executing and gets interrupted, RCOUNT may be cleared by the Interrupt Service Routine (ISR) to break out of the `REPEAT` loop when the foreground code is re-entered.

1.11. STATUS Register

The 32-bit STATUS Register maintains status information for the instructions which have been executed most recently. Operation Status bits exist for MCU operations, loop operations and DSP operations. Additionally, the STATUS Register contains the CPU Interrupt Priority Level bits, `IPL[2:0]`,

which are used as a context identifier and for interrupt processing. See [SR](#) for more detailed information.

1.11.1. MCU ALU Status Bits

The MCU operation Status bits are either affected or used by the majority of instructions in the instruction set. Most of the logic, math, rotate/shift and bit instructions modify the MCU Status bits after execution, and the conditional branch instructions use the state of individual Status bits to determine the flow of program execution. All conditional branch instructions are listed in [Conditional Branch Instructions](#).

The Carry (C), Zero (Z), Overflow (OV) and Negative (N) bits show the immediate status of the MCU ALU by indicating whether an operation has resulted in a Carry, Zero, Overflow or Negative result. When a subtract operation is performed, the C flag is used as a Borrow flag.

The Z Status bit is useful for extended precision arithmetic. The Z Status bit functions like a normal Z flag for all instructions except those that use a carry or borrow input (ADDC, CPB, SUBB and SUBBR). See [Z Status Bit](#) for more detailed information.

Note:

1. All MCU bits are stacked during exception processing (see [Software Stack Pointer](#)).

1.11.2. REPEAT Loop Active (RA) Status Bit

The `REPEAT` Loop Active bit (RA) is used to indicate when looping is active. The RA flag indicates that a `REPEAT` instruction is being executed, and it is only affected by the `REPEAT` instructions. The RA flag is set to '1' when the instruction being repeated begins execution, and it is cleared when the instruction being repeated completes execution for the last time.

Since the RA flag is also read-only, it may not be directly cleared. However, if a `REPEAT` or its target instruction is interrupted, the Interrupt Service Routine may clear the RA flag, which resides on the stack. This action will disable looping once program execution returns from the Interrupt Service Routine because the restored RA will be '0'.

1.11.3. DSP ALU Status Bits

The high byte of the STATUS Register is used by the DSP class of instructions and it is modified when data passes through one of the adders. It provides status information about overflow and saturation for both accumulators. The Saturate A, Saturate B, Overflow A and Overflow B (SA, SB, OA, OB) bits provide individual accumulator status, while the Saturate AB and Overflow AB (SAB, OAB) bits provide combined accumulator status. The SAB and OAB bits provide an efficient method for the software developer to check the register for saturation or overflow.

The OA and OB bits are used to indicate when an operation has generated an overflow into the Guard bits (bits 63 through 71) of the respective accumulator. This condition can only occur when the processor is in Super Saturation mode or if saturation is disabled. It indicates that the operation has generated a number which cannot be represented with the lower 62 bits of the accumulator.

The SA and SB bits are used to indicate when an operation has generated an overflow out of the MSb of the respective accumulator. The SA and SB bits are active, regardless of the Saturation mode (Disabled, Normal or Super) and may be considered "sticky." Namely, once the SA or SB bit is set to '1', it can only be cleared by software, regardless of subsequent DSP operations. When it is required, the `BCLR` instruction can be used to clear the SA or SB bit.

In addition, the SA and SB bits can be set by software, enabling efficient context state switching.

For convenience, the OA and OB bits are logically ORed together to form the OAB flag, and the SA and SB bits are logically ORed to form the SAB flag. These cumulative Status bits provide efficient overflow and saturation checking when an algorithm is implemented. Instead of interrogating the OA and OB bits independently for arithmetic overflows, a single check of OAB can be performed.

Likewise, when checking for saturation, SAB may be examined instead of checking both the SA and SB bits. Note that clearing the SAB flag will clear both the SA and SB bits.

1.11.4. Interrupt Priority Level Status Bits

The three Interrupt Priority Level (IPL) bits of the SRL (SR[7:5]) and the IPL3 bit (SR[8]) set the CPU's IPL, which is used for exception processing. Exceptions consist of interrupts and hardware traps. Interrupts have a user-defined priority level between 0 and 7, while traps have a fixed priority level between 8 and 15. The fourth Interrupt Priority Level bit, IPL3, is a special IPL bit that may only be read or cleared by the user. This bit is only set when a hardware trap is activated, and it is cleared after the trap is serviced.

The CPU's IPL identifies the lowest level exception which may interrupt the processor. The interrupt level of a pending exception must always be greater than the CPU's IPL for the CPU to process the exception. This means that if the IPL is 0, all exceptions at Priority Level 1 and above may interrupt the processor. If the IPL is 7, only hardware traps may interrupt the processor.

When an exception is serviced, the IPL is automatically set to the priority level of the exception being serviced, which will disable all exceptions of equal and lower priority. However, since the IPL field is read/write, one may modify the lower three bits of the IPL in an Interrupt Service Routine to control which exceptions may preempt the exception processing. Since the SRL is stacked during exception processing, the original IPL is always restored after the exception is serviced. If required, one may also prevent exceptions from nesting by setting the NSTDIS bit (INTCON1[15]).

1.12. Core Control Register

The Core Control register (CORCON) is used to set the configuration of the CPU.

In addition to setting CPU modes, the following features are available through the CORCON register:

- Sets the ACCA and ACCB saturation enable
- Sets the Data Space Write Saturation mode
- Sets the Accumulator Saturation and Rounding modes
- Sets the Multiplier mode for DSP operations

1.13. CPU STATUS Register

Name: SR

Notes:

1. This bit may be read or cleared (not set). Clearing this bit will clear SA and SB irrespective of the value simultaneously written to SA and/or SB.
2. IPL[2:0] become read only bits if NSTDIS(INTCON1[15])=1 (nesting disabled).

Legend: C = Clearable bit

Bit	31	30	29	28	27	26	25	24
Access								
Reset								
Bit	23	22	21	20	19	18	17	16
Access	VF						CTX[2:0]	
Reset	R					R	R	R
Bit	15	14	13	12	11	10	9	8
Access	OA	OB	SA	SB	OAB	SAB		IPL3
Reset	R/W	R/W	R/W	R/W	R	R/C		R/C
Bit	7	6	5	4	3	2	1	0
Access	IPL[2:0]			RA	N	OV	Z	C
Reset	R/W	R/W	R/W	R	R/W	R/W	R/W	R/W

Bit 23 – VF Vector (Fetch) Fail Status

Value	Description
1	Indicates to the bus error handler that the source of the bus error is a vector fetch. The vector data read will be substituted with the contents of the Vector Fail Address (VFA) SFR.
0	Indicates to the bus error handler that the source of the bus error is not a vector fetch.

Bits 18:16 – CTX[2:0] Current (W register) Context Identifier

Identifies which W register context is currently in use by the CPU

Value	Description
111	Context 7 is currently in use
110	Context 6 is currently in use
101	Context 5 is currently in use
100	Context 4 is currently in use
011	Context 3 is currently in use
010	Context 2 is currently in use
001	Context 1 is currently in use
000	Context 0 is currently in use

Bit 15 – OA Accumulator A Fractional Overflow Status

Value	Description
1	Accumulator A fractional overflow has occurred (its contents can no longer be represented as a 1.31 fractional value)

Value	Description
0	Accumulator A not overflowed

Bit 14 – OB Accumulator B Fractional Overflow Status

Value	Description
1	Accumulator A fractional overflow has occurred (its contents can no longer be represented as a 1.31 fractional value)
0	Accumulator A not overflowed

Bit 13 – SA Accumulator A Saturation/Sign Overflow 'Sticky' Status

Value	Description
1	Accumulator A is saturated or has been saturated at some time, or has overflowed into bit 71 (if saturation is disabled)
0	Accumulator A is not saturated or has not overflowed into bit 71 (if saturation is disabled)

Bit 12 – SB Accumulator B Saturation/Sign Overflow 'Sticky' Status

Value	Description
1	Accumulator B is saturated or has been saturated at some time, or has overflowed into bit 71 (if saturation is disabled)
0	Accumulator B is not saturated or has not overflowed into bit 71 (if saturation is disabled)

Bit 11 – OAB OA || OB Combined Accumulator Fractional Overflow Status

Value	Description
1	Accumulators A or B fractional overflow has occurred (one or both of their contents can no longer be represented as a 1.31 fractional value)
0	Neither Accumulators A nor B have overflowed

Bit 10 – SAB SA || SB Combined Accumulator 'Sticky' Status⁽¹⁾

Value	Description
1	Accumulators A or B are saturated or have been saturated at some time, or have overflowed into bit 71 (if saturation is disabled)
0	Neither Accumulator A nor B are saturated or have overflowed into bit 71 (if saturation is disabled)

Bit 8 – IPL3 MSb (Most Significant bit) of CPU Priority Level Nibble

Value	Description
1	CPU Priority ≥ 8 (trap exception underway)
0	CPU Priority < 8 (no trap exception underway)

Bits 7:5 – IPL[2:0] CPU Interrupt Priority Level Status⁽²⁾

Value	Description
111	All interrupts disabled
110	Level 7 interrupts enabled
101	Level 6 and 7 interrupts enabled
100	Level 5 through 7 interrupts enabled
011	Level 4 through 7 interrupts enabled
010	Level 3 through 7 interrupts enabled
001	Level 2 through 7 interrupts enabled
000	Level 1 through 7 interrupts enabled

Bit 4 – RA REPEAT Loop Active

Value	Description
1	REPEAT loop in progress
0	REPEAT loop not in progress

Bit 3 – N MCU ALU Negative

Value	Description
1	Result was negative
0	Result was non-negative (zero or positive)

Bit 2 – OV MCU ALU Overflow

This bit is used for signed arithmetic (2's complement). It indicates an overflow of the magnitude that causes the Sign bit to change state.

Value	Description
1	Overflow occurred for signed arithmetic (in this arithmetic operation)
0	No overflow occurred

Bit 1 – Z MCU ALU 'Sticky' Zero

Value	Description
1	An operation which effects the Z bit has set it at some time in the past
0	The most recent operation which effects the Z bit has cleared it (i.e., a non-zero result)

Bit 0 – C MCU ALU Carry/Borrow

Value	Description
1	A carry-out from the MSb of the result occurred
0	No carry-out from the MSb of the result occurred

1.14. Core Control Register

Name: CORCON

Note:

1. This bit has no effect if US = 1 (Unsigned mode).

Bit	31	30	29	28	27	26	25	24
Access								
Reset								
Bit	23	22	21	20	19	18	17	16
Access								
Reset								
Bit	15	14	13	12	11	10	9	8
Access				US				
Reset				R/W 0				
Bit	7	6	5	4	3	2	1	0
Access	SATA	SATB	SATDW	ACCSAT			RND	IF
Reset	R/W 0	R/W 0	R/W 1	R/W 0			R/W 0	R/W 0

Bit 12 – US DSP Multiply Unsigned/Signed Control

Value	Description
1	DSP Engine Unsigned mode enabled
0	DSP Engine Signed mode enabled

Bit 7 – SATA ACCA Saturation Enable⁽¹⁾

Value	Description
1	Accumulator A saturation is enabled
0	Accumulator A saturation is disabled

Bit 6 – SATB ACCB Saturation Enable⁽¹⁾

Value	Description
1	Accumulator B saturation is enabled
0	Accumulator B saturation is disabled

Bit 5 – SATDW Data Space Write from DSP Engine Saturation Enable

Value	Description
1	Data Space write saturation is enabled
0	Data Space write saturation is disabled

Bit 4 – ACCSAT Accumulator Saturation Mode Select

Value	Description
1	9.31 Saturation (super saturation)
0	1.31 Saturation (normal saturation)

Bit 1 – RND Rounding Mode Select

Value	Description
1	Biased (conventional) rounding is enabled
0	Unbiased (convergent) rounding is enabled

Bit 0 – IF Integer or Fractional Multiplier Mode Select

Value	Description
1	Integer mode is enabled for DSP multiply
0	Fractional mode is enabled for DSP multiply

2. Instruction Set Overview

The dsPIC33A instruction set provides a broad suite of instructions that includes traditional microcontroller applications and DSP-based math-intensive applications. Since almost all of the functionality of the 16-bit MCU and DSC instruction set has been maintained, this hybrid instruction set allows an easy 32-bit migration path for users already familiar with the PIC microcontroller architecture and instructions.

Instructions can be grouped into the functional categories, as shown in [Table 2-1](#). [Table 2](#) defines the symbols used in the instruction summary tables. [Table 2-1](#) through [Table 2-13](#) define the syntax, description, storage and execution requirements for each instruction. Storage requirements are represented in 32-bit instruction words and execution requirements are represented in instruction cycles.

Table 2-1. Instruction Groups

Functional Group	Summary Table
Move Instructions	Table 2-3
Math Instructions	Table 2-4
Logic Instructions	Table 2-5
Rotate/Shift Instructions	Table 2-6
Bit Instructions	Table 2-7
Compare/Skip and Compare/Branch Instructions	Table 2-8
Program Flow Instructions	Table 2-9
Shadow/Stack Instructions	Table 2-10
Control Instructions	Table 2-11
DSP Instructions	Table 2-12
FPU Instructions	Table 2-13

Several instructions have different addressing modes and execution flows, which require different instruction variants. For instance, there are up to seven unique `ADD` instructions and each instruction variant has its own instruction encoding. Instruction format descriptions and specific instruction operations are provided in [Instruction Descriptions](#). Additionally, a composite alphabetized instruction set table is provided in the [Reference](#) section.

2.1. Multicycle Instructions

As shown in the instruction summary tables, most instructions execute in a single cycle with the following exceptions:

- `ASRM`, `LSRM`, `ED`, `EDAC` and a few other instructions require two cycles to execute.
- Instructions `DIVF`, `DIVFL`, `DIVU`, `DIVUL`, `DIVS`, and `DIVSL` are single-cycle instructions, which should be executed consecutive times as the target of a `REPEAT` instruction.
- Instructions that change the Program Counter require two cycles to execute. Instructions such as `CALL` also require two cycles to execute.
- `RETFIE`, `RETLW` and `RETURN` are a special case of an instruction that changes the Program Counter. These execute in three to four cycles, unless an exception is pending, and then they execute in two cycles.

The cycle count of program flow change instructions also depend on the status of PBU cache. The table below shows the cycle counts of these instructions under different scenarios.

Table 2-2. Program Flow Control and Instruction Execution Times

Instruction	Cycle Counts		
	Cache/ISB Hit	Cache/ISB Miss	Execution from RAM
Conditional Branch ¹	1 (3)	1 (6 to 9)	1 (3)
BRA	1	4-7	1
BRA W	5-8	5-8	2
CALL	1	4-7	1
CALL W	5-8	5-8	2
GOTO	1	4-7	1
GOTO W	5-8	5-8	2
RCALL	1	4-7	1
RCALL W	5-8	5-8	2
RETFIE	7-10	7-10	4
RETLW	6-9	6-9	3
RETURN	6-9	6-9	3

Note:
1. Branch taken execution times in () brackets.

2.2. Multiword Instructions

As defined by [Table 2-3](#) through [Table 2-13](#), almost all instructions consume one instruction word (32 bits), with the exception of the `CALL` and `GOTO` instructions, which are program flow instructions listed in [Table 2-9](#). These instructions require two words of memory because their opcodes embed large literal operands.

2.3. Instruction Set Summary Tables

Table 2-3. Move Instructions

Assembled Syntax	Description	Words	Cycles
<code>EXCH Wns, Wnd</code>	Swap Wns with Wnd	1	2
<code>MOV Ws, Wd</code>	Move Ws to Wd	0.5/1	1
<code>MOV.l lit32, Wnd</code>	Move 32-bit unsigned literal to Wnd	2	2
<code>MOV.sl lit24, Wnd</code>	Move 24-bit unsigned literal to Wnd; 0 extend to 32-bits	1	1
<code>MOV.w lit16, Wnd</code>	Move 16-bit unsigned literal to Wnd; 0 extend to 32-bits	1	1
<code>MOV.bz lit8, Wnd</code>	Move 8-bit unsigned literal to Wnd; 0 extend to 32-bits	1	1
<code>MOV.l [W15-lit7], Wnd [W14+slit7], Wnd</code>	Move from system stack with literal offset to Wnd using SP or FP	0.5	1
<code>MOV.l Wns, [W15-lit7] Wns, [W14+slit7]</code>	Move from Wns to system stack with literal off-set using SP or FP	0.5	1
<code>MOV.l f, Wnd</code>	Move f to Wnd (Word or Long Word)(f < ~1MB)	1	1
<code>MOV.b f, Wnd</code>	Move f to Wnd (Byte)	1	1
<code>MOV.l Wns, f</code>	Move Wns to f (Word or Long Word)(f < ~1MB)	1	1
<code>MOV.w Wns, f</code>	Move Wns to f (Word or Long Word)(f > ~1MB)	2	2
<code>MOV.b Wns, f</code>	Move Wns to f (Byte)	1	1
<code>MOV [Wns+Slit12], Wnd</code>	Move [Wns+Slit12] to Wnd	1	1

Table 2-3. Move Instructions (continued)

Assembled Syntax	Description	Words	Cycles
MOV Wns, [Wnd+Slit12]	Move Wns to [Wnd+Slit12]	1	1
MOVIF.l CC, Wb, Wns, Wd	If CC == True Move W1 to [W15++] Else Move W2 to [W15++] where, CC -> Z, N, C, OV, GT, LT, GTU	1	1
MOVR.l	Move Ws to Wd with destination Bit Reversed addressing		
MOVS.l slit16, Wd	Move signed extended 16-bit literal to Wd	1	1
MOVS.b slit8, Wnd	Move 8-bit literal to Wd; no extension.	1	1
SWAP Wn	Wn = Word or byte swap Wn	1	1
TST f	Test f	1	1
TST f, Wnd	Test f and move f to Wnd	1	1

Table 2-4. Math Instructions

Assembled Syntax	Description	Words	Cycles
ADD f, Wn	$f = f + Wn$	1	1
ADD f, Wn, Wn	$Wn = f + Wn$	1	1
ADD.l lit5, Wn	$Wn = Wn + lit5$	0.5	1
ADD lit16, Wn	$Wn = Wn + lit16$	1	1
ADD Wb, Ws, Wd	$Wd = Wb + Ws$	0.5/1	1
ADD Wb, lit7, Wd	$Wd = Wb + lit7$ (literal zero-extended)	1	1
ADDC f, Wn	$f = f + Wn + (C)$	1	1
ADDC f, Wn, Wn	$Wn = f + Wn + (C)$	1	1
ADDC lit16, Wn	$Wn = Wn + lit16 + (C)$	1	1
ADDC Wb, Ws, Wd	$Wd = Wb + Ws + (C)$	0.5/1	1
ADDC Wb, lit7, Wd	$Wd = Wb + lit7 + (C)$ (literal zero-extended)	1	1
DEC f	$f = f - 1$	1	1
DEC f, Wd	$W5 = f - 1$	1	1
DEC Ws, Wd	$Wd = Ws - 1$	1	1
DEC2 f	$f = f - 2$	1	1
DEC2 f, Wd	$W5 = f - 2$	1	1
DEC2 Ws, Wd	$Wd = Ws - 2$	1	1
DIVF Wm/Wn	Interruptible Signed 16/16 or 32/16 Fractional Divide	1	1
DIVFL Wm/Wn	Interruptible Signed 32/32 Fractional Divide	1	1
DIVS.w Wm/Wn	Interruptible Signed 16/16-bit Integer Divide	1	1
DIVS.l Wm/Wn	Interruptible Signed 32/16-bit Integer Divide	1	1
DIVSL Wm/Wn	Interruptible Signed 32/32 Integer Divide	1	1
DIVU.w Wm/Wn	Interruptible Unsigned 16/16-bit Integer Divide	1	1
DIVU.l Wm/Wn	Interruptible Unsigned 32/16-bit Integer Divide	1	1
DIVUL Wm/Wn	Interruptible Unsigned 32/32 Integer Divide	1	1

Table 2-4. Math Instructions (continued)

Assembled Syntax	Description	Words	Cycles
FLIM Wb, Ws	Force Data (Upper and Lower) Range Limit without Limit Excess Result	1	1
FLIM Wb, Ws, Wd	Force Data (Upper and Lower) Range Limit with Limit Excess Flag (Wd=-1)	1	2
FLIM.V Wb, Ws, Wd	Force Data (Upper and Lower) Range Limit with Limit Excess Result	1	2
INC f	$f = f + 1$	1	1
INC f, Wd	$W5 = f + 1$	1	1
INC Ws, Wd	$Wd = Ws + 1$	1	1
INC2 f	$f = f + 2$	1	1
INC2 f, Wd	$W5 = f + 2$	1	1
INC2 Ws, Wd	$Wd = Ws + 2$	1	1
MULSS Wb, Ws, Wnd	$\{Wd\} = \text{signed}(Wb) * \text{signed}(Ws)$	0.5/1	1
MULSU Wb, Ws, Wnd	$\{Wd\} = \text{signed}(Wb) * \text{unsigned}(Ws)$	0.5/1	1
MULUS Wb, Ws, Wnd	$\{Wd\} = \text{unsigned}(Wb) * \text{signed}(Ws)$	0.5/1	1
MULUU Wb, Ws, Wnd	$\{Wd\} = \text{unsigned}(Wb) * \text{unsigned}(Ws)$	0.5/1	1
MULSU Wb, lit8, Wnd	$\{Wd\} = \text{signed}(Wb) * \text{unsigned}(lit8)$	1	1
MULUU Wb, lit8, Wnd	$\{Wd\} = \text{unsigned}(Wb) * \text{unsigned}(lit8)$	1	1
MULSS Wb, slit8, Wnd	$\{Wd\} = \text{signed}(Wb) * \text{signed}(slit8)$	1	1
MULUS Wb, slit8, Wnd	$\{Wd\} = \text{unsigned}(Wb) * \text{signed}(slit8)$	1	1
MUL f, Wn	$W2 = f * Wn$	1	1
SE Ws, Wnd	$Wd = \text{sign-extended } Ws$	0.5/1	1
SUB f, Wn	$f = f - Wn$	1	1
SUB f, Wn, Wn	$Wn = f - Wn$	1	1
SUB.l lit5, Wn	$Wn = Wn - lit5$	0.5	1
SUB lit16, Wn	$Wn = Wn - lit16$	1	1
SUB Wb, Ws, Wd	$Wd = Wb - Ws$	0.5/1	1
SUB Ws, lit7, Wd	$Wd = Ws - lit7$ (literal zero-extended)	1	1
SUBB f, Wn	$f = f - Wn - (C)$	1	1
SUBB f, Wn, Wn	$Wn = f - Wn - (C)$	1	1
SUBB lit16, Wn	$Wn = Wn - lit16 - (C)$	1	1
SUBB Wb, Ws, Wd	$Wd = Wb - Ws - (C)$	0.5/1	1
SUBB Ws, lit7, Wd	$Wd = Ws - lit7 - (C)$ (literal zero-extended)	1	1
SUBR f, Wn	$f = Wn - f$	1	1
SUBR f, Wn, Wn	$Wn = Wn - f$	1	1
SUBR Wb, Ws, Wd	$Wd = Ws - Wb$	0.5/1	1
SUBR Ws, lit7, Wd	$Wd = lit7 - Ws$ (literal zero-extended)	0.5/1	1
SUBBR f, Wn	$f = Wn - f - (C)$	1	1
SUBBR f, Wn, Wn	$Wn = Wn - f - (C)$	1	1
SUBBR Wb, Ws, Wd	$Wd = Ws - Wb - (C)$	0.5/1	1
SUBBR Ws, lit7, Wd	$Wd = lit7 - Ws - (C)$ (literal zero-extended)	1	1
ZE Ws, Wnd	$Wd = \text{Zero-extend } Ws$	0.5/1	1

Table 2-5. Logic Instructions

Assembled Syntax	Description	Words	Cycles
AND f, Wn	$f = f .AND. Wn$	1	1

Table 2-5. Logic Instructions (continued)

Assembled Syntax	Description	Words	Cycles
AND f,Wn,Wn	W0 = f .AND. Wn	1	1
AND lit16,Wn	Wn = Wn .AND. lit16	1	1
AND Wb,Ws,Wd	Wd = Wb .AND. Ws	0.5/1	1
AND Wb,lit7,Wd	Wd = Wb .AND. Lit7 (literal zero-extended)	1	1
AND1 Wb,lit7,Wd	Wd = Wb .AND. Lit7 (literal zero-extended)	1	1
CLR f	f = 0x0000	1	1
CLR Wd	Wd = 0x0000	1	1
COM f	f = f	1	1
COM f,Wd	Wd = f	1	1
COM Ws,Wd	Wd = Ws	0.5/1	1
IOR f,Wn	f = f .IOR. Wn	1	1
IOR f,Wn,Wn	Wn = f .IOR. Wn	1	1
IOR lit16,Wn	Wn = Wn .IOR. lit16	1	1
IOR Wb,Ws,Wd	Wd = Wb .IOR. Ws	0.5/1	1
IOR Wb,lit7,Wd	Wd = Wb .IOR. lit7	1	1
NEG f	f = $\bar{f} + 1$	1	1
NEG f,Wd	Wd = $\bar{f} + 1$	1	1
NEG Ws,Wd	Wd = $\overline{Ws} + 1$	0.5/1	1
SETM f	f = 0xFFFF	1	1
SETM Wd	Wd = 0xFFFF	1	1
XOR f,Wn	f = f .XOR. Wn	1	1
XOR f,Wn,Wn	Wn = f .XOR. Wn	1	1
XOR lit16,Wn	Wn = Wn .XOR. lit16	1	1
XOR Wb,Ws,Wd	Wd = Wb .XOR. Ws	0.5/1	1
XOR Wb,lit7,Wd	Wd = Wb .XOR. Lit7 (literal zero-extended)	1	1

Table 2-6. Rotate/Shift Instructions

Assembled Syntax	Description	Words	Cycles
ASR f	f = Arithmetic Right Shift f by 1	1	1
ASR f,Wn	Wn = Arithmetic Right Shift f by 1	1	1
ASR Ws,Wd	Wd = Arithmetic Right Shift Ws by 1	0.5/1	1
ASR Ws,Wb,Wd	Wnd = Arithmetic Right Shift Ws by Wb	0.5/1	1
ASR Ws,lit5,Wd	Wnd = Arithmetic Right Shift Ws by lit5	0.5/1	1
ASRM Ws, lit5, Wnd	Wnd = Arithmetic Right Shift Ws by lit5, then logically OR with next lsw	1	2
ASRM Ws, Wb, Wnd	Wnd = Arithmetic Right Shift Ws by Wb, then logically OR with next lsw	1	2
LSR f	f = Logical Right Shift f by 1	1	1
LSR f,Wd	Wd = Logical Right Shift f by 1	1	1
LSR Ws,Wd	Wd = Logical Right Shift Ws by 1	0.5/1	1
LSR Ws,Wb,Wd	Wnd = Logical Right Shift Ws by Wns	0.5/1	1
LSR Ws,lit5,Wd	Wnd = Logical Right Shift Ws by lit5	0.5/1	1
LSRM Ws, lit5, Wnd	Wnd = Logical Right Shift Ws by lit5, then logically OR with next lsw	1	2
LSRM Ws, Wb, Wnd	Wnd = Logical Right Shift Ws by Wb, then logically OR with next lsw	1	2
RLC f	f = Rotate Left through Carry f	1	1

Table 2-6. Rotate/Shift Instructions (continued)

Assembled Syntax	Description	Words	Cycles
RLC f, Wd	Wd = Rotate Left through Carry f	1	1
RLC Ws, Wd	Wd = Rotate Left through Carry Ws	0.5/1	1
RLNC f	f = Rotate Left (No Carry) f	1	1
RLNC f, Wd	Wd = Rotate Left (No Carry) f	1	1
RLNC Ws, Wd	Wd = Rotate Left (No Carry) Ws	0.5/1	1
RRC f	f = Rotate Right through Carry f	1	1
RRC f, Wd	Wd = Rotate Right through Carry f	1	1
RRC Ws, Wd	Wd = Rotate Right through Carry Ws	0.5/1	1
RRNC f	f = Rotate Right (No Carry) f	1	1
RRNC f, Wd	Wd = Rotate Right (No Carry) f	1	1
RRNC Ws, Wd	Wd = Rotate Right (No Carry) Ws	0.5/1	1
SL f	f = Left Shift f by 1	1	1
SL f, Wd	Wd = Left Shift f by 1	1	1
SL Ws, Wd	Wd = Left Shift Ws by 1	0.5/1	1
SL Ws, Wb, Wnd	Wnd = Left Shift Wb by Wns	0.5/1	1
SL Ws, lit5, Wnd	Wnd = Left Shift Ws by lit5	0.5/1	1
SLM Ws, lit5, Wnd	Wnd = Left Shift Wb by lit5, then logically OR with next msw	1	2
SLM Ws, Wb, Wnd	Wnd = Left Shift Wb by Wb, then logically OR with next msw	1	2

Table 2-7. Bit Instructions

Assembled Syntax	Description	Words	Cycles
BCLR.b f, bit3	Bit Clear f	1	1
BCLR Ws, bit5	Bit Clear Ws	0.5/1	1
BFEXT bit5, wid6, Ws, Wb	Bit Field Extract from Ws to Wb	1	1
BFEXT bit5, wid6, f, Wb	Bit Field Extract from f to Wb	2	2
BFINS bit5, wid6, Wb, Ws	Bit Field Insert from Wb into Ws	1	1
BFINS bit5, wid6, Wb, f	Bit Field Insert from Wb into f	2	2
BFINS bit5, wid6, lit16, Ws	Bit Field Insert lit8 into Ws	2	2
BSET.b f, bit3	Bit Set f	1	1
BSET Ws, bit5	Bit Set Ws	0.5/1	1
BSW.C Ws, Wb	Write C or Z bit to Ws<Wb>	1	1
BSW.Z Ws, Wb	Write C or Z bit to Ws<Wb>	0.5/1	1
BTG.b f, bit3	Bit Toggle f	1	1
BTG Ws, bit5	Bit Toggle Ws	0.5/1	1
BTST.b f, bit3	Bit Test f	1	1
BTST.C Ws, bit5	Bit Test Ws to C	0.5/1	1
BTST.Z Ws, bit5	Bit Test Ws to Z	1	1
BTST.C Ws, Wb	Bit Test Ws<Wb> to C	0.5/1	1
BTST.Z Ws, Wb	Bit Test Ws<Wb> to Z	1	1
BTSTS.b f, bit3	Bit Test then Set f	1	1
BTSTS.C Ws, bit5	Bit Test Ws to C then Set	0.5/1	1
BTSTS.Z Ws, bit5	Bit Test Ws to Z then Set	1	1
FBCL Ws, Wnd	Find Bit Change from Left (MSb) Side	1	1
FF1L Ws, Wnd	Find First One from Left (MSb) Side	1	1

Table 2-7. Bit Instructions (continued)

Assembled Syntax	Description	Words	Cycles
FF1R Ws,Wnd	Find First One from Right (LSb) Side	1	1

Table 2-8. Compare/Skip and Compare/Branch Instructions

Assembled Syntax	Description	Words	Cycles
CP f,Ws	Compare f with Ws	1	1
CP Ws,lit13	Compare Ws with lit13 (literal zero-extended)	1	1
CP Wb,lit16	Compare Wb with lit16 (literal zero-extended)	1	1
CP Wb, Ws	Compare Wb with Ws	0.5/1	1
CP0 f	Compare f with 0x0000	1	1
CP0 Ws	Compare Ws with 0x0000 (substitute CPLS Ws,#0)	1	1
CPB f,Ws	Compare f with Ws, with borrow	1	1
CP Wb,lit13	Compare Wb with lit13, with borrow (literal zero-extended)	1	1
CP Wb,lit16	Compare Wb with lit16, with borrow (literal zero-extended)	1	1
CPB Wb,Ws	Compare Borrow Wb with Ws	0.5/1	1
DTB Wn,Label	Decrement Wn, then branch if not zero	1	1(2/3)

Table 2-9. Program Flow Instructions

Assembled Syntax	Description	Words	Cycles
BRA Label	Branch Unconditionally	1	1
BRA Wn	Computed Branch	1	2
BRA C,Label	Branch if Carry	1	1(2/3)
BRA GE,Label	Branch if greater than or equal	1	1(2/3)
BRA GEU,Label	Branch if unsigned greater than or equal	1	1(2/3)
BRA GT,Label	Branch if greater than	1	1(2/3)
BRA GTU,Label	Branch if unsigned greater than	1	1(2/3)
BRA LE,Label	Branch if less than or equal	1	1(2/3)
BRA LEU,Label	Branch if unsigned less than or equal	1	1(2/3)
BRA LT,Label	Branch if less than	1	1(2/3)
BRA LTU,Label	Branch if unsigned less than	1	1(2/3)
BRA N,Label	Branch if Negative	1	1(2/3)
BRA NC,Label	Branch if Not Carry	1	1(2/3)
BRA NN,Label	Branch if Not Negative	1	1(2/3)
BRA NOV,Label	Branch if Not Overflow	1	1(2/3)
BRA NZ,Label	Branch if Not Zero	1	1(2/3)
BRA Z,Label	Branch if Zero	1	1(2/3)
BREAK	Stop user code execution	0.5/1	1
CALL Label	Call subroutine (label < ~ 16MB)	1	1
CALL Wns	Call indirect subroutine at address [W11]	1	2
GOTO Label	Goto address (address < ~ 16MB)	1	1
GOTO Wn	Go to indirect address at [W11]	1	2
RCALL Label	Relative Call	1	1
RCALL Wns	Computed Call	1	2

Table 2-9. Program Flow Instructions (continued)

Assembled Syntax	Description	Words	Cycles
REPEAT lit15	Repeat Next Instruction lit15+1 times	1	1
REPEAT lit5	Repeat Next Instruction lit5+1 times	0.5	1
REPEAT Wn	Repeat Next Instruction (Wn)+1 times	1	1
RETFIE	Return from interrupt enable	0.5	4
RETLW lit16, Wn	Return from Subroutine with literal in Wn	1	3
RETURN	Return from Subroutine	0.5	3

Table 2-10. Shadow/Stack/Context Instructions

Assembled Syntax	Description	Words	Cycles
BOOTSWP	Swap Active and Inactive address space	0.5	2
CTXTSWP lit3	Swap to CPU register context #2	0.5	2
CTXTSWP Wn	Swap to CPU register context defined in Wn[2:0]	1	2
LNK lit16	Link frame pointer	1	1
LNK lit7	Link frame pointer (literal < 128)	0.5	1
POP f	Pop f from top of stack (TOS)	1	1
POP {[--Ws],} Wnd	Pop Wnd Register from system stack.	0.5	1
POP Fd	Pop Fd Register from system stack.	0.5	1
PUSH f	Push f to top of stack (TOS)	1	1
PUSH Wns, {[Wd++]}	Push Wns Register to system stack	0.5	1
PUSH Fs	Push Fs Register to system stack	0.5	1
ULNK	Unlink frame pointer	0.5	1

Table 2-11. Control Instructions

Assembled Syntax	Description	Words	Cycles
CLRWDT	Clear Watchdog Timer	0.5	1
DISICTL lit3 {,Wd}	Disable interrupts at IPL <= lit3 Optionally save prior IPL threshold to Wd	1	1
DISICTL Wns {,Wd}	Disable interrupts at IPL <= Wns[2:0] Optionally save prior IPL threshold to Wd	1	1
NEOP	None executable NOP (16-bit instruction pad)	0.5	0
NOP	No Operation	1	1
NOPR	No Operation	1	1
PWRSV mode	Go into standby mode	0.5	2
RESET	Software device RESET	1	1

Table 2-12. DSP Instructions

Assembled Syntax	Description	Words	Cycles
ADD A	Add Accumulators	0.5	1
ADD Ws, Slit6, A	Signed Add to Accumulator	1	1

Table 2-12. DSP Instructions (continued)

Assembled Syntax	Description	Words	Cycles
BRA OA,Label	Branch if accumulator A overflow	1	1(2/3)
BRA OB,Label	Branch if accumulator B overflow	1	1(2/3)
BRA OV,Label	Branch if Overflow	1	1(2/3)
BRA SA,Label	Branch if accumulator A saturated	1	1(2/3)
BRA SB,Label	Branch if accumulator B saturated	1	1(2/3)
CLR A	Clear Accumulator	0.5	1
ED Wx, Wy, A, AWB	Euclidean Distance	1	2
EDAC Wx, Wy, A, AWB	Euclidean Distance Accumulate	1	2
LAC Ws,Slit6, A	Load Accumulator (16/32-bit), literal shift	1	1
LLAC.l Ws Slit6, A	Load Lower (LS-word of) Accumulator (32-bit), literal shift	1	1
IUAC.l Ws, Slit6, A	Load Upper (LS-byte) of Accumulator (32-bit), literal shift	1	1
MAC Wx, Wy, A, AWB	Multiply and Accumulate	1	1
MAX Wb, Ws	Force Data Maximum Range Limit	1	1
MAX A	Force Data Maximum Range Limit	0.5	1
MAX.V A, Wd	Force Data Maximum Range Limit with Result	1	2
MIN Wb, Ws	Force Data Minimum Range Limit	1	1
MIN A	Force Data Minimum Range Limit	0.5	1
MIN.V A, Wd	Force Data Minimum Range Limit with Result	1	2
MULISS Wb,Ws,A	Integer: Acc(A or B) = signed(Wb) * signed(Ws)	1	1
MULFSS Wb,Ws,A	Fractional: Acc(A or B) = signed(Wb) * signed(Ws)	1	1
MULISU Wb,Ws,A	Integer: Acc(A or B) = signed(Wb) * unsigned(Ws)	1	1
MULFSU Wb,Ws,A	Fractional: Acc(A or B) = signed(Wb) * unsigned(Ws)	1	1
MULIUS Wb,Ws,A	Integer: Acc(A or B) = unsigned(Wb) * signed(Ws)	1	1
MULFUS Wb,Ws,A	Fractional: Acc(A or B) = unsigned(Wb) * signed(Ws)	1	1
MULIUU Wb,Ws,A	Integer: Acc(A or B) = unsigned(Wb) * unsigned(Ws)	1	1
MULFUU Wb,Ws,A	Fractional: Acc(A or B) = unsigned(Wb) * unsigned(Ws)	1	1
MULISS Wb,slit8,A	Integer: Acc(A or B) = signed(Wb) * signed(slit8)	1	1

Table 2-12. DSP Instructions (continued)

Assembled Syntax	Description	Words	Cycles
MULFSS Wb, slit8, A	Integer: Acc(A or B) = signed(Wb) * signed(slit8)	1	1
MULISU Wb, lit8, A	Integer: Acc(A or B) = signed(Wb) * unsigned(lit8)	1	1
MULFSU Wb, lit8, A	Integer: Acc(A or B) = signed(Wb) * unsigned(lit8)	1	1
MULIUS Wb, slit8, A	Integer: Acc(A or B) = signed(Wb) * signed(slit8)	1	1
MULFUS Wb, slit8, A	Integer: Acc(A or B) = signed(Wb) * signed(slit8)	1	1
MULIUU Wb, lit8, A	Integer: Acc(A or B) = signed(Wb) * unsigned(lit8)	1	1
MULFUU Wb, lit8, A	Integer: Acc(A or B) = signed(Wb) * unsigned(lit8)	1	1
MPY Wx, Wy, A, AWB	Multiply Wm by Wn to Accumulator	1	1
MPYN Wx, Wy, A, AWB	-(Multiply Wm by Wn) to Accumulator	1	1
MSC Wx, Wy, A, AWB	Multiply and Subtract from Accumulator	1	1
NEG A	Negate Accumulator	0.5	1
NORM A, Wd	Normalize Accumulator	1	1
SAC A, Slit6, Wd	Store Accumulator (16/32-bit)	1	1
SACR A, Slit6, Wd	Store Rounded Accumulator (16/32-bit), literal shift	1	1
SACR A, Ws, Wd	Store Rounded Accumulator (16/32-bit), Wb shift	1	1
SLAC.l A, Slit6, Wd	Store Lower (LS-Word of) Accumulator (32-bit), literal shift	1	1
SUAC.l A, Slit6, Wd	Store sign extended Upper (MS-Byte of) Accumulator (32-bit), literal shift	1	1
SFTAC A, Wn	Arithmetic Shift by (Wn) Accumulator	1	1
SFTAC A, Slit7	Arithmetic Shift by Slit7 Accumulator	1	1
SQR Wx, A, AWB	Square to Accumulator	1	1
SQRAC Wx, A, AWB	Square and Accumulate	1	1
SQRN Wx, A, AWB	Negated Square to Accumulator	1	1
SQRSC Wx, A, AWB	Square and Subtract from Accumulator	1	1
SUB A	Subtract Accumulators	0.5	1
SUB Ws, Slit6, A	Signed Subtract from Accumulator	1	1

Table 2-13. FPU Instructions

Assembled Syntax	Description	Words	Cycles
ABS Fs, Fd	Absolute value of Fs	1	1
ADD Fb, Fs, Fd	Fd = Fb + Fs	1	2

Table 2-13. FPU Instructions (continued)

Assembled Syntax	Description	Words	Cycles
AND lit16, FSR	FSR = FSR AND lit16	1	1
AND lit16, FCR	FCR = FCR AND lit16	1	1
AND lit16, FEAR	FEAR = FEAR AND lit16	1	1
COS Fs, Fd	Fd = COS(Fs)	1	4
CPQ Fb, Fs	Compare Fb with Fs, Quiet Signaling	1	1
CPS Fb, Fs	Compare Fb with Fs, Signaling	1	1
DI2F Fs, Fd	Convert Double Word (64-bit) Integer to Floating-Point, Fs (integer) -->Fd (float)	1	2
DIV Fb, Fs, Fd	Signed Floating-Point Divide, Fd = Fb/Fs	1	11/32
FBRA EQ, Label	Floating Point Branch if Equal	1	1(2/3)
FBRA NE, Label	Floating Point Branch if Not Equal	1	1(2/3)
FBRA GT, Label	Floating Point Branch if Greater Than	1	1(2/3)
FBRA GE, Label	Floating Point Branch if Greater Than or Equal	1	1(2/3)
FBRA LT, Label	Floating Point Branch if Less Than	1	1(2/3)
FBRA LE, Label	Floating Point Branch if Less Than or Equal	1	1(2/3)
FBRA OR, Label	Floating Point Branch if Ordered	1	1(2/3)
FBRA UNE, Label	Floating Point Branch if Unordered or Not Equal	1	1(2/3)
FBRA UEQ, Label	Floating Point Branch if Unordered or Equal	1	1(2/3)
FBRA ULE, Label	Floating Point Branch if Unordered or Less Than or Equal	1	1(2/3)
FBRA ULT, Label	Floating Point Branch if Unordered or Less Than	1	1(2/3)
FBRA UGE, Label	Floating Point Branch if Unordered or Greater Than or Equal	1	1(2/3)
FBRA UGT, Label	Floating Point Branch if Unordered or Greater Than	1	1(2/3)
FBRA UN, Label	Floating Point Branch if Unordered	1	1(2/3)
FLIM Fb, Fs, Fd	Force Signed Data Limit, If Fd > Fs Then Fd = Fs If Fd < Fb then Fd = Fb	1	1
F2DI Fs, Fd	Convert Floating-Point Fs to Double Word (64-bit) Integer, Fs (float)--> Fd (integer)	1	1/2
F2LI Fs, Fd	Convert Floating-Point Fs to Long Word (32-bit) Integer, Fs (float)-->Fd (integer)	1	1/2
IOR lit16, FSR	Inclusive OR FSR, FSR = FSR .IOR. lit16	1	1

Table 2-13. FPU Instructions (continued)

Assembled Syntax	Description	Words	Cycles
IOR lit16, FCR	Inclusive OR FCR, FCR = FCR .IOR. Lit16	1	1
IOR lit16, FEAR	Inclusive OR FEAR, FEAR = FEAR .IOR. Lit16	1	1
LI2F Fs, Fd	Convert Long Word (32-bit) Integer to Floating-Point, Fs (integer)-->Fd (float)	1	1
MAC Fb, Fs, Fd	Floating-Point Signed Multiply and Accumulate, Fd = Fd +(Fb * Fs)	1	3/4
MAX Fb, Fs, Fd	Select the Signed Maximum of Fb and Fs {IEEE 754-2019 maximum(x,y)}, if Fs >= Fb then Fd = Fs Else Fd= Fb	1	1
MAXNM Fb, Fs, Fd	Select the Signed Maximum of Fb and Fs {IEEE 754-2019 maximumNumber(x,y)},, if Fs >= Fb then Fd = Fs Else Fd= Fb	1	1
MIN Fb, Fs, Fd	Select the Signed Minimum of Fb and Fs {IEEE 754-2019 minimum(x,y)}, if Fs <= Fb then Fd = Fs Else Fd= Fb	1	1
MINNM Fb, Fs, Fd	Select the Signed Minimum of Fb and Fs [minimumNumber()], if Fs <= Fb then Fd = Fs Else Fd= Fb	1	1
MOV.l Fs, Wd	Move coprocessor register to Wd	0.5/1	1
MOV.l Ws, Fd	Move Ws to coprocessor register	0.5/1	1
MOV.l lit32, Fd	Move 32-bit unsigned literal to coprocessor register	2	2
MOV Fs, [Wnd+Slit12]	Move Fs to [Wnd+Slit12]	1	1
MOV [Wns+Slit12], Fd	Move [Wns+Slit12] to Fd	1	1
MOV Fs, Fd	Move Fs to Fd	1	1
MOV index, Fd	Fd = Constant table (index) Fd	1	1
MUL Fb, Fs, Fd	Fd = Fb * Fs	1	3
NEG Fs, Fd	Fd = -Fs	1	1
SIN Fs, Fd	Fd = SIN(Fs)	1	4
SQRT Fs, Fd	Fd = \sqrt{Fs}	1	10/13
SUB Fb, Fs, Fd	Fd= Fb- Fs	1	2
TST Fs	Test Fs	1	1

3. Instruction Set Details

3.1. Data Addressing Modes

The dsPIC33A devices support three native addressing modes for accessing data memory. Data accesses may be performed using File Register Addressing, Register Direct or Indirect Addressing, and a few Immediate Addressing types, allowing a fixed value to be used by the instruction.

File Register Addressing provides the ability to operate on data stored up to 64 KB (if a WREG operand is required), and the MOV instruction provides access to all 1 MB of data space. Register Direct Addressing is used to access the 16 memory-mapped Working registers, W0:W15. Register Indirect Addressing is used to efficiently operate on data stored in the entire data space, using the contents of the Working registers as an Effective Address (EA). Immediate Addressing does not access data memory but provides the ability to use a constant value as an instruction operand. The address range of each mode is summarized in [Table 3-1](#).

Table 3-1. dsPIC33A Addressing Modes

Addressing Mode	Address Range
File Register	Upto 64 KB/1 MB
Register Direct	0x000F (Working register array, W0:W15)
Register Indirect	0x0000-0xFFFFFFFF
Immediate	N/A (constant value)

3.1.1. File Register Addressing

File Register Addressing is used by instructions that use a predetermined data address as an operand for the instruction. The majority of instructions that support File Register Addressing provide access up to 64 KB (if a WREG operand is required). However, the MOV instruction provides access to all 1 MB of memory using File Register Addressing. This allows the loading of the data from any location in data memory to any Working register and storing the contents of any Working register to any location in data memory. It should be noted that File Register Addressing supports byte, extended byte, word and long word data sizes. Refer to [Example 3-1](#) of File Register Addressing modes.

Most instructions which support File Register Addressing perform an operation on the specified file register and the default Working register, WREG. If only one operand is supplied in the instruction, WREG is an implied operand and the operation results are stored back to the file register. In these cases, the instruction is effectively a Read-Modify-Write instruction. However, when both the file register and the WREG register are specified in the instruction, the operation results are stored in the WREG register and the contents of the file register are unchanged. Sample instructions that show the interaction between the file register and the WREG register are shown in [Example 3-2](#).

Note: Instructions which support File Register Addressing use 'f' as an operand in the instruction summary tables of [Instruction Set Overview](#).

Example 3-1. File Register Addressing

```
DEC    0x5000    ; decrement data stored at 0x5000
```

Before Instruction:

```
Data Memory 0x5000 = 0x55555555
```

After Instruction:

```
Data Memory 0x5000 = 0x55555554
```

```
MOV.L    0x000027FE, W0    ; move data stored at 0x000027FE to W0
```

Before Instruction:

```
W0 = 0x55555555
Data Memory 0x000027FE = 0x12345678
```

After Instruction:

```
W0 = 0x12345678
Data Memory 0x000027FE = 0x12345678
```

Example 3-2. File Register Addressing and WREG

```
AND     0x00001000    ; AND 0x00001000 with WREG, store to 0x00001000
```

Before Instruction:

```
W0 (WREG) = 0x0000332C
Data Memory 0x00001000 = 0x55555555
```

After Instruction:

```
W0 (WREG) = 0x0000332C
Data Memory 0x00001000 = 0x00001104
```

```
AND     0x00001000, WREG    ; AND 0x00001000 with WREG, store to WREG
```

Before Instruction:

```
W0 (WREG) = 0x0000332C
Data Memory 0x00001000 = 0x55555555
```

After Instruction:

```
W0 (WREG) = 0x00001104
Data Memory 0x00001000 = 0x55555555
```

3.1.2. Register Direct Addressing

Register Direct Addressing is used to access the contents of the 16 Working registers (W0:W15). The Register Direct Addressing mode is fully orthogonal, which allows any Working register to be specified for any instruction that uses Register Direct Addressing, and it supports byte, word, and long word accesses. Instructions which employ Register Direct Addressing use the contents of the specified Working register as data to execute the instruction; therefore, this addressing mode is useful only when data already resides in the Working register core. Sample instructions which utilize Register Direct Addressing are shown in [Example 3-3](#).

Another feature of Register Direct Addressing is that it provides the ability for dynamic flow control. Since variants of the `REPEAT` instruction support Register Direct Addressing, flexible looping constructs may be generated using these instructions.

Note: Instructions that must use Register Direct Addressing use the symbols W_b , W_n , W_{ns} and W_{nd} in the summary tables of [Instruction Set Overview](#). Commonly, Register Direct Addressing may also be used when Register Indirect Addressing may be used. Instructions that use Register Indirect Addressing use the symbols W_d and W_s in the summary tables of [Instruction Set Overview](#).

Example 3-3. Register Direct Addressing

```
EXCH    W2, W3    ; Exchange W2 and W3
```

Before Instruction:

```
W2 = 0x00003499
W3 = 0x0000003D
```

After Instruction:

```
W2 = 0x0000003D
W3 = 0x00003499
```

```
IOR.L   #0x44, W0    ; Inclusive-OR 0x44 and W0
```

Before Instruction:

```
W0 = 0x12349C2E
```

After Instruction:

```
W0 = 0x12349C6E
```

```
SL      W6, W7, W8    ; Shift left W6 by W7, and store to W8
```

Before Instruction:

```
W6 = 0x0000000C
W7 = 0x00000008
W8 = 0x12345678
```

After Instruction:

```
W6 = 0x0000000C
W7 = 0x00000008
W8 = 0x00000C00
```

3.1.3. Register Indirect Addressing

Register Indirect Addressing is used to access any location in data memory by treating the contents of a Working register as an Effective Address (EA) to data memory. Essentially, the contents of the Working register become a pointer to the location in data memory that is to be accessed by the instruction.

This addressing mode is powerful because it also allows one to modify the contents of the Working register, either before or after the data access is made, by incrementing or decrementing the EA. By modifying the EA in the same cycle that an operation is being performed, Register Indirect Addressing allows for the efficient processing of data that is stored sequentially in memory. The modes of Indirect Addressing supported by dsPIC33A devices are shown in [Table 3-2](#).

Table 3-2. Indirect Addressing Modes

Indirect Mode	Syntax	Function (Byte Instruction)	Function (Word Instruction)	Function (Long word instruction)	Description
No Modification	[Wn]	EA = [Wn]	EA = [Wn]	EA = [Wn]	The contents of Wn form the EA.
Pre-Increment	[++Wn]	EA = [Wn + = 1]	EA = [Wn + = 2]	EA = [Wn + = 4]	Wn is pre-incremented to form the EA.
Pre-Decrement	[--Wn]	EA = [Wn - = 1]	EA = [Wn - = 2]	EA = [Wn - = 4]	Wn is pre-decremented to form the EA.
Post-Increment	[Wn++]	EA = [Wn] + = 1	EA = [Wn] + = 2	EA = [Wn] + = 4	The contents of Wn form the EA, then Wn is post-incremented.
Post-Decrement	[Wn--]	EA = [Wn] - = 1	EA = [Wn] - = 2	EA = [Wn] - = 4	The contents of Wn form the EA, then Wn is post-decremented.
Register Offset	[Wn+Wb]	EA = [Wn + Wb]	EA = [Wn + Wb]	EA = [Wn + Wb]	The sum of Wn and Wb forms the EA. Wn and Wb are not modified.

Table 3-2 shows that four addressing modes modify the EA used in the instruction, and this allows the following updates to be made to the Working register: post-increment, post-decrement, pre-increment and pre-decrement.

Table 3-2 also shows that the Register Offset mode addresses data which is offset from a base EA stored in a Working register. This mode uses the contents of a second Working register to form the EA by adding the two specified Working registers. Note that neither of the Working registers used to form the EA is modified. Example 3-4 shows how Register Offset Indirect Addressing may be used to access data memory.

Note: The MOV with offset instructions provides a literal addressing offset ability to be used with Indirect Addressing. In these instructions, the EA is formed by adding the contents of a Working register to a signed literal. Example 3-5 shows how these instructions may be used to move data to and from the Working register array.

Example 3-4. Indirect Addressing with Effective Address Update

```
MOV.B      [W0++], [W13--]      ; byte move [W0] to [W13]
; post-inc W0, post-dec W13
```

Before Instruction:

```
W0 = 0x2300
W13 = 0x2708
Data Memory 0x2300 = 0x7783
Data Memory 0x2708 = 0x904E
```

After Instruction:

```
W0 = 0x2301
W13 = 0x2707
Data Memory 0x2300 = 0x7783
Data Memory 0x2708 = 0x9083
```

```
ADD      W1, [--W5], [++W8]      ; pre-dec W5, pre-inc W8
; add W1 to [W5], store in [W8]
```

Before Instruction:

```

W1 = 0x0800
W5 = 0x2200
W8 = 0x2400
Data Memory 0x21FE = 0x7783
Data Memory 0x2402 = 0xAACC

```

After Instruction:

```

W1 = 0x0800
W5 = 0x21FE
W8 = 0x2402
Data Memory 0x21FE = 0x7783
Data Memory 0x2402 = 0x7F83

```

Example 3-5. Indirect Addressing with Register Offset

```

MOV.B      [W0+W1], [W7++]      ; byte move
; [W0+W1] to W7, post-inc W7

```

Before Instruction:

```

W0 = 0x2300
W1 = 0x01FE
W7 = 0x1000
Data Memory 0x24FE = 0x7783
Data Memory 0x1000 = 0x11DC

```

After Instruction:

```

W0 = 0x2300
W1 = 0x01FE
W7 = 0x1001
Data Memory 0x24FE = 0x7783
Data Memory 0x1000 = 0x1183

```

```

LAC.l      [W0+W8], A          ; load ACCA with [W0+W8]
; (sign-extend and zero-backfill)

```

Before Instruction:

```

W0 = 0x2344
W8 = 0x0008
ACCA = 0x00 7877 9321 0000 0000
Data Memory 0x234C = 0xE290

```

After Instruction:

```

W0 = 0x2344
W8 = 0x0008
ACCA = 0xFF E290 0000 0000 0000
Data Memory 0x234C = 0xE290

```

Example 3-6. Move with Literal Offset Instructions

```

MOV        [W0+0x20], W1      ; move [W0+0x20] to W1

```

Before Instruction:

```

W0 = 0x1200
W1 = 0x01FE
Data Memory 0x1220 = 0xFD27

```

After Instruction:

```
W0 = 0x1200
W1 = 0xFD27
Data Memory 0x1220 = 0xFD27
```

```
MOV      W4, [W8-0x300]      ; move W4 to [W8-0x300]
```

Before Instruction:

```
W4 = 0x3411
W8 = 0x2944
Data Memory 0x2644 = 0xCB98
```

After Instruction:

```
W4 = 0x3411
W8 = 0x2944
Data Memory 0x2644 = 0x3411
```

3.1.3.1. Register Indirect Addressing and the Instruction Set

The addressing modes presented in [Table 4-2](#) demonstrate the Indirect Addressing mode capability of the dsPIC33A devices. Due to operation encoding and functional considerations, not every instruction which supports Indirect Addressing supports all modes shown in [Table 4-2](#). The majority of instructions which use Indirect Addressing support the No Modify, Pre-Increment, Pre-Decrement, Post-Increment and Post-Decrement Addressing modes. The `MOV` instructions and several accumulator-based DSP instructions are also capable of using the Register Offset Addressing mode.

Note: Instructions that use Register Indirect Addressing use the operand symbols W_d and W_s in the summary tables of [Instruction Set Overview](#).

3.1.3.2. DSP MAC Indirect Addressing Modes

A special class of Indirect Addressing modes is utilized by the DSP MAC instructions. As is described later in [DSP MAC Instructions](#), the DSP MAC class of instructions is capable of performing two fetches from memory using Effective Addressing. Since DSP algorithms frequently demand a broader range of address updates, the addressing modes offered by the DSP MAC instructions provide greater range in the size of the Effective Address update which may be made. The following table shows that both X and Y prefetches support Post-Increment and Post-Decrement Addressing modes with updates of two, four and six bytes. Since DSP instructions only execute in Word/Long-word mode, no provisions are made for odd-sized EA updates.

Table 3-3. DSP MAC Indirect Addressing Modes

Addressing Mode	Word-Mode		Long-Word Mode	
	X Memory	Y Memory	X Memory	Y Memory
Indirect with No Modification	EA = [Wx]	EA = [Wy]	EA = [Wx]	EA = [Wy]
Indirect with Post-Increment by two	EA = [Wx] + = 2	EA = [Wy] + = 2	EA = [Wx] + = 4	EA = [Wy] + = 4
Indirect with Post-Increment by four	EA = [Wx] + = 4	EA = [Wy] + = 4	EA = [Wx] + = 8	EA = [Wy] + = 8
Indirect with Post-Increment by six	EA = [Wx] + = 6	EA = [Wy] + = 6	EA = [Wx] + = 12	EA = [Wy] + = 12
Indirect with Post-Decrement by two	EA = [Wx] - = 2	EA = [Wy] - = 2	EA = [Wx] - = 4	EA = [Wy] - = 4
Indirect with Post-Decrement by four	EA = [Wx] - = 4	EA = [Wy] - = 4	EA = [Wx] - = 8	EA = [Wy] - = 8
Indirect with Post-Decrement by six	EA = [Wx] - = 6	EA = [Wy] - = 6	EA = [Wx] - = 12	EA = [Wy] - = 12
Indirect with Register Offset	EA = [W9 + W12]	EA = [W11 + W12]	EA = [W9 + W12]	EA = [W11 + W12]

3.1.3.3. Modulo and Bit-Reversed Addressing Modes

The dsPIC33A architecture provides support for two special Register Indirect Addressing modes that are commonly used to implement DSP algorithms. Modulo (or circular) Addressing provides an automated means to support circular data buffers in X and/or Y memory. Modulo buffers remove the need for software to perform address boundary checks, which can improve the performance of certain algorithms. Similarly, Bit-Reversed Addressing allows one to access the elements of a buffer in a nonlinear fashion. This addressing mode simplifies data re-ordering for radix-2 FFT algorithms and provides a significant reduction in FFT processing time.

Both of these addressing modes are powerful features of the dsPIC33A architectures, which can be exploited by any instruction that uses Indirect Addressing.

3.1.4. Immediate Addressing

In Immediate Addressing, the instruction encoding contains a predefined constant operand that is used by the instruction. This addressing mode may be used independently, but it is more frequently combined with the File Register, Direct and Indirect Addressing modes. The size of the immediate operand which may be used varies with the instruction type. Constants of size 1-bit (#lit1), 5-bit (#bit5, #lit5 and #Slit5), 7-bit (#lit7), 6-bit (#Slit6), 8-bit (#lit8), 14-bit (#Slit14), 16-bit (#lit16), 20-bit (#lit20, #Slit20), and 32-bit (#lit32) may be used. Constants may be signed or unsigned, and the symbols #Slit6, #Slit8, and #Slit20 designate a signed constant. All other immediate constants are unsigned. [Table 3-4](#) shows the usage of each immediate operand in the instruction set.

Table 3-4. Immediate Operands in the Instruction Set

Operand	Instruction Usage
#lit1	PWRSVAV
#lit3	CTXTSWP DISICTL
#bit5	BCLR, BSET, CLRWDI, BTG, BTST, BTSTS
#lit5	ASR, LSR, SL
#wid6	BFEXT, BFINS
#lit7	ADD, ADDC, AND, CP, CPB, IOR, SUB, SUBB, SUBBR, SUBR, XOR
#Slit6	SFTAC
#lit8	MOV.B, MULSU, MULUU, MULIUU, MULISU
#lit7	ADD, ADDC, AND, CP, CPB, IOR, RETLW, SUB, SUBB, XOR
#Slit6	LAC, LLAC, LUAC, SAC, SLAC, SUAC, SFTAC, SACR, SUB
#lit16	LNK, RETLW, MOV, SUB, SUBB, XOR, ADD, ADDC, AND, CP, IOR
#lit20	REPEAT
#lit16	MOV
#lit32	MOV, CALL, GOTO

The syntax for Immediate Addressing requires that the number sign (#) must immediately precede the constant operand value. The “#” symbol indicates to the assembler that the quantity is a constant. If an out-of-range constant is used with an instruction, the assembler will generate an error. Several examples of Immediate Addressing are shown in [Example 3-7](#).

Example 3-7. Immediate Addressing

```
PWRSVAV    #1           ; Enter IDLE mode
ADD.B     #0x10, W0      ; Add 0x10 to W0 (byte mode)
```

Before Instruction:

```
W0 = 0x12A9
```

```

After Instruction:

W0 = 0x12B9
XOR     W0, #1, [W1++]           ; Exclusive-OR W0 and 0x1
                                ; Store the result to
[W1]                               ; Post-increment W1

Before Instruction:

W0 = 0xFFFF
W1 = 0x0890
Data Memory 0x0890 = 0x0032

After Instruction:

W0 = 0xFFFF
W1 = 0x0892
Data Memory 0x0890 = 0xFFFE
    
```

3.2. Data Addressing Mode Tree

The Data Addressing modes of the dsPIC33A family are summarized in [Figure 3-1](#).

Figure 3-1. Data Addressing Mode Tree

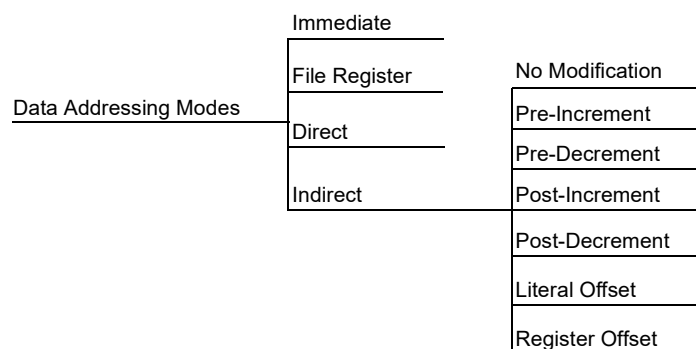

3.3. Program Addressing Modes

The dsPIC33A devices have a 24-bit Program Counter (PC). The PC addresses the 24-bit wide program memory to fetch instructions for execution and it may be loaded in several ways. Instructions are either 16-bit, 32-bit or 64-bit entities; therefore, the PC is incremented by 2, 4 or 8 during sequential 16-bit, 32-bit or 64-bit instruction execution, respectively.

Several methods may be used to modify the PC in a non-sequential manner and both absolute and relative changes may be made to the PC. The change to the PC may be from an immediate value encoded in the instruction or a dynamic value contained in a Working register. For exception handling, the PC is loaded with the address of the exception handler, which is stored in the Interrupt Vector Table (IVT). When required, the software stack is used to return scope to the foreground process from where the change in program flow occurred.

[Table 3-5](#) summarizes the instructions which modify the PC. When performing function calls, it is recommended that `RCALL` be used instead of `CALL`, since `RCALL` only consumes one word of program memory.

Table 3-5. Methods of Modifying Program Flow

Condition/Instruction	PC Modification	Software Stack Usage
Sequential Execution	PC = (PC + 2) / (PC + 4) / (PC + 8) Depending on size of the instruction.	None
BRA Expr ⁽¹⁾ (Branch Unconditionally)	PC = PC + Expr	None
BRA Condition, Expr ⁽¹⁾ (Branch Conditionally)	PC = PC + 4 (condition false) PC = PC + Expr (condition true)	None
CALL Expr ⁽¹⁾ (Call Subroutine)	PC = lit24	PC + 4 is PUSHed on the stack ⁽²⁾
CALL Wn (Call Subroutine Indirect)	PC = Wn	PC + 4 is PUSHed on the stack ⁽²⁾
GOTO Expr ⁽¹⁾ (Unconditional Jump)	PC = lit24	None
GOTO Wn (Unconditional Indirect Jump)	PC = Wn	None
RCALL Expr ⁽¹⁾ (Relative Call)	PC = (PC + 4) + Expr	PC + 4 is PUSHed on the stack ⁽²⁾
RCALL Wn (Computed Relative Call)	PC = (PC + 4) + Wn	PC + 4 is PUSHed on the stack ⁽²⁾
Exception Handling	PC = Address of the exception handler (read from vector table)	PC + 4 is PUSHed on the stack ⁽³⁾
PC = Target REPEAT instruction (REPEAT Looping)	PC not modified (if REPEAT active)	None

Notes:

1. For BRA, CALL and GOTO, the Expr may be a label, absolute address or expression, which is resolved by the linker to a 20-bit or 24-bit value (slit20 or lit24). When representing an address offset value, Expr can also be indicated by using a "." and a sign, "+" or "-". For example, the expression, ".+2", means an address offset of +2 (i.e., the next instruction address relative to the current position of the Program Counter). See [Instruction Descriptions](#) for details.
2. After CALL or RCALL is executed, RETURN or RETLW will POP the Top-of-Stack (TOS) back into the PC.
3. After an exception is processed, RETFIE will POP the Top-of-Stack (TOS) back into the PC.

3.4. Instruction Stalls

In order to maximize device throughput, all instructions are pipelined. A consequence of this pipelining is that address register data dependencies may arise between successive read and write operations using common registers.

'Read-After-Write' (RAW) dependencies occur across instruction boundaries and are detected by the hardware. An example of a RAW dependency would be a write operation that modifies W5, followed by a read operation that uses W5 as an Address Pointer. The contents of W5 will not be valid for the read operation until the earlier write completes. This problem is resolved by stalling the instruction execution for one instruction cycle, which allows the write to complete before the next read is started.

3.4.1. RAW Dependency Detection

During the Read-After-Write (RAW) instruction predecode, the core determines if any address register dependency is imminent across an instruction boundary. The stall detection logic compares the W register (if any) used for the destination EA of the instruction currently being executed with the W register to be used by the source EA (if any) of the prefetched instruction. When a match between the destination and source registers is identified, a set of rules is applied to decide whether or not to stall the instruction by one cycle. [Table 3-6](#) lists various RAW conditions that cause an instruction execution stall.

Table 3-6. Raw Dependency Rules (Detection By Hardware)

Destination Addressing Mode Using Wn	Source Addressing Mode Using Wn	Stall Required?	Examples ⁽²⁾ (Wn = W2)
Direct	Direct	No Stall	ADD.W W0, W1, W2 MOV.W W2, W3
Indirect	Direct	No Stall	ADD.W W0, W1, [W2] MOV.W W2, W3
Indirect	Indirect	No Stall	ADD.W W0, W1, [W2] MOV.W [W2], W3
Indirect	Indirect with Pre/Post-Modification	No Stall	ADD.W W0, W1, [W2] MOV.W [W2++], W3
Indirect with Pre/Post-Modification	Direct	No Stall	ADD.W W0, W1, [W2++] MOV.W W2, W3
Direct	Indirect	Stall ⁽¹⁾	ADD.W W0, W1, W2 MOV.W [W2], W3
Direct	Indirect with Pre/Post-Modification	Stall ⁽¹⁾	ADD.W W0, W1, W2 MOV.W [W2++], W3
Indirect	Indirect	Stall ⁽¹⁾	ADD.W W0, W1, [W2] (2) MOV.W [W2], W3 (2)
Indirect	Indirect with Pre/Post-Modification	Stall ⁽¹⁾	ADD.W W0, W1, [W2] (2) MOV.W [W2++], W3 (2)
Indirect with Pre/Post-Modification	Indirect	Stall ⁽¹⁾	ADD.W W0, W1, [W2++] MOV.W [W2], W3
Indirect with Pre/Post-Modification	Indirect with Pre/Post-Modification	Stall ⁽¹⁾	ADD.W W0, W1, [W2++] MOV.W [W2++], W3

When stalls are detected, one cycle is added to the instruction execution time.
For these examples, the contents of W2 = the mapped address of W2 (0x0004).

Note: When Register Indirect with Offset Addressing is used to specify the destination for an instruction, and w_s is the same register as w_d , the old value of w_s is used for w_d (i.e., the address offset is ignored).

3.4.2. Instruction Stalls and Exceptions

In order to maintain deterministic operation, instruction stalls are allowed to happen, even if they occur immediately prior to exception processing.

3.4.3. Instruction Stalls and Instructions that Change Program Flow

CALL and RCALL write to the stack using W15; therefore, they may be subject to an instruction stall if the source read of the subsequent instruction uses W15.

GOTO, RETFIE and RETURN instructions are never subject to an instruction stall because they do not perform write operations to the Working registers.

3.4.4. Instruction Stalls and REPEAT Loops

Instructions operating in a REPEAT loop are subject to instruction stalls, just like any other instruction. Stalls may occur on loop entry, loop exit and also during loop processing.

3.5. Byte Operations

Since the data memory is byte-addressable, most of the base instructions may operate in either Byte mode or Word mode. When these instructions operate in Byte mode, the following rules apply:

- All direct Working register references use the Least Significant Byte (LSB) of the 32-bit Working register and leave the Most Significant Byte (MSB) unchanged

- All indirect Working register references use the data byte specified by the 32-bit address stored in the Working register
- All file register references use the data byte specified by the byte address
- The STATUS Register (SR) is updated to reflect the result of the byte operation

It should be noted that data addresses are always represented as byte addresses. Additionally, the native data format is little-endian, which means that words are stored with the LSB at the lower address and the MSB at the adjacent, higher address (as shown in [Figure 3-2](#)). [Example 3-8](#) shows sample byte move operations and [Example 3-9](#) shows sample byte math operations.

Note: The instructions that operate in Byte mode must use the “.b” or “.B” instruction extension to specify a byte instruction. For example, the following two instructions are valid forms of a byte clear operation: `CLR.b W0` or `CLR.B W0`.

Example 3-8. Sample Byte Move Operations

```
MOV.B    #0x30, W0    ; move the literal byte 0x30 to W0
```

Before Instruction:

```
W0 = 0x5555
```

After Instruction:

```
W0 = 0x5530
```

```
MOV.B    0x1000, W0   ; move the byte at 0x1000 to W0
```

Before Instruction:

```
W0 = 0x5555
Data Memory 0x1000 = 0x1234
```

After Instruction:

```
W0 = 0x5534
Data Memory 0x1000 = 0x1234
```

```
MOV.B    W0, 0x1001  ; byte move W0 to address 0x1001
```

Before Instruction:

```
W0 = 0x1234
Data Memory 0x1000 = 0x5555
```

After Instruction:

```
W0 = 0x1234
Data Memory 0x1000 = 0x3455
```

```
MOV.B    W0, [W1++]  ; byte move W0 to [W1], then post-inc W1
```

Before Instruction:

```
W0 = 0x1234
W1 = 0x1001
Data Memory 0x1000 = 0x5555
```

After Instruction:

```
W0 = 0x1234
W1 = 0x1002
Data Memory 0x1000 = 0x3455
```

Example 3-9. Sample Byte Math Operations

```
CLR.B      [W6--]      ; byte clear [W6], then post-dec W6
```

Before Instruction:

```
W6 = 0x1001
Data Memory 0x1000 = 0x5555
```

After Instruction:

```
W6 = 0x1000
Data Memory 0x1000 = 0x0055
```

```
SUB.B      W0, #0x10, W1      ; byte subtract literal 0x10 from W0
                                   ; and store to W1
```

Before Instruction:

```
W0 = 0x1234
W1 = 0xFFFF
```

After Instruction:

```
W0 = 0x1234
W1 = 0xFF24
```

```
ADD.B      W0, W1, [W2++]      ; byte add W0 and W1, store to [W2]
                                   ; and post-inc W2
```

Before Instruction:

```
W0 = 0x1234
W1 = 0x5678
W2 = 0x1000
Data Memory 0x1000 = 0x5555
```

After Instruction:

```
W0 = 0x1234
W1 = 0x5678
W2 = 0x1001
Data Memory 0x1000 = 0x55AC
```

3.6. Word Move Operations

Even though the data space is byte-addressable, all move operations made in Word mode must be word-aligned. This means that for all source and destination operands, the Least Significant Address bit must be '0'. Likewise, for long-word accesses, last 2 bits of addresses must be zero. If a word/long-word move is made to or from an unaligned address, an address error exception is generated. [Figure 3-2](#) shows how bytes and words may be aligned in data memory. [Example 3-10](#) contains several legal word move operations.

When an exception is generated due to a misaligned access, the exception is taken after the instruction executes. If the illegal access occurs from a data read, the operation will be allowed to complete, but the Least Significant bit (LSb) of the source address will be cleared to force word alignment. If the illegal access occurs during a data write, the write will be inhibited. [Example 3-11](#) contains several illegal word move operations.

Figure 3-2. Data Alignment in Memory

0x4001		b0	0x4000
0x4003	b1		0x4002
0x4005	b3	b2	0x4004
0x4007	b5	b4	0x4006
0x4009	b7	b6	0x4008
0x400B		b8	0x400A

Legend:

- b0 – byte stored at 0x4000
- b1 – byte stored at 0x4003
- b5:b2 – long-word stored at 0x4007:4004 (b2 is LSB)
- b7:b6 – word stored at 0x4009:0x4008 (b6 is LSB)
- b8 – byte stored at 0x400A

Note: Instructions that operate in Word mode are not required to use an instruction extension. However, they may be specified with an optional “.w” or “.W” extension. For example, the following instructions are valid forms of a word clear operation: CLR W0 or CLR.w W0 or CLR.W W0.

Example 3-10. Legal Word Move Operations

```
MOV    #0x30, W0    ; move the literal word 0x30 to W0
```

Before Instruction:

```
W0 = 0x5555
```

After Instruction:

```
W0 = 0x0030
```

```
MOV    0x1000, W0   ; move the word at 0x1000 to W0
```

Before Instruction:

```
W0 = 0x5555
Data Memory 0x1000 = 0x1234
```

After Instruction:

```
W0 = 0x1234
Data Memory 0x1000 = 0x1234
```

```
MOV    [W0], [W1++] ; word move [W0] to [W1],
; then post-inc W1
```

Before Instruction:

```
W0 = 0x1234
W1 = 0x1000
```

```
Data Memory 0x1000 = 0x5555
Data Memory 0x1234 = 0xAAAA
```

After Instruction:

```
W0 = 0x1234
W1 = 0x1004
Data Memory 0x1000 = 0xAAAA
Data Memory 0x1234 = 0xAAAA
```

Example 3-11. Illegal Word Move Operations

```
MOV      0x1001, W0          ; move the word at 0x1001 to W0
```

Before Instruction:

```
W0 = 0x5555
Data Memory 0x1000 = 0x1234
Data Memory 0x1002 = 0x5678
```

After Instruction:

```
W0 = 0x1234
Data Memory 0x1000 = 0x1234
Data Memory 0x1002 = 0x5678
```

ADDRESS ERROR TRAP GENERATED

(source address is misaligned, so MOV is performed)

```
MOV      W0, 0x1001        ; move W0 to the word at 0x1001
```

Before Instruction:

```
W0 = 0x1234
Data Memory 0x1000 = 0x5555
Data Memory 0x1002 = 0x6666
```

After Instruction:

```
W0 = 0x1234
Data Memory 0x1000 = 0x5555
Data Memory 0x1002 = 0x6666
```

ADDRESS ERROR TRAP GENERATED

(destination address is misaligned, so MOV is not performed)

```
MOV      [W0], [W1++]      ; word move [W0] to [W1],
; then post-inc W1
```

Before Instruction:

```
W0 = 0x1235
W1 = 0x1000
Data Memory 0x1000 = 0x1234
Data Memory 0x1234 = 0xAAAA
Data Memory 0x1236 = 0xB BBB
```

After Instruction:

```
W0 = 0x1235
W1 = 0x1002
Data Memory 0x1000 = 0xAAAA
```

```
Data Memory 0x1234 = 0xAAAA
Data Memory 0x1236 = 0xBBBB
```

ADDRESS ERROR TRAP GENERATED

(source address is misaligned, so MOV is performed)

3.7. Using 16-Bit Literal Operands

Several instructions that support Byte and Word mode have 16-bit operands. For byte instructions, a 16-bit literal is too large to use. Therefore, when 16-bit literals are used in Byte mode, the range of the operand must be reduced to eight bits or the assembler will generate an error. Likewise, the literal is zero-extended to 32-bits for long-word instructions. Likewise, the literal is zero-extended to 32-bits for long-word instructions. Table 3-7 shows that the range of a 16-bit literal is 0:65535 in Word/long-word mode and 0:255 in Byte mode.

Instructions that employ 16-bit literals in Byte and Word/Long-Word mode are ADD, ADDC, AND, IOR, RETLW, SUB, SUBB and XOR. Example 3-12 shows how positive and negative literals are used in Byte mode for the ADD instruction.

Table 3-7. 16-Bit Literal Coding

Literal Value	Word/long-word Mode kk kkkk kkkk	Byte Mode kkkk kkkk
0	0000 0000 0000 0000	0000 0000
1	0000 0000 0000 0001	0000 0001
2	0000 0000 0000 0010	0000 0010
127	0000 0000 0111 1111	0111 1111
128	0000 0000 1000 0000	1000 0000
255	0000 0000 1111 1111	1111 1111
256	0000 0001 0000 0000	N/A
512	0000 0010 0000 0000	N/A
1023	0000 0011 1111 1111	N/A
65535	1111 1111 1111 1111	N/A

Note: Using a literal value greater than 127 in Byte mode is functionally identical to using the equivalent negative two's complement value, since the MSb of the byte is set. When operating in Byte mode, the assembler will accept either a positive or negative literal value (i.e., #-10).

Example 3-12. Using 16-Bit Literals for Byte Operands

```
ADD.B    #0x80, W0      ; add 128 (or -128) to W0
ADD.B    #0x380, W0    ; ERROR... Illegal syntax for byte mode
ADD.B    #0xFF, W0     ; add 255 (or -1) to W0
ADD.B    #0x3FF, W0    ; ERROR... Illegal syntax for byte mode
ADD.B    #0xF, W0      ; add 15 to W0
ADD.B    #0x7F, W0     ; add 127 to W0
ADD.B    #0x100, W0    ; ERROR... Illegal syntax for byte mode
```

3.8. Bit Field Insert/Extract Instructions

dsPIC33A provides a set of instructions that operate on bit fields within a target word.

3.8.1. BFEXT

This instruction can extract multiple bits from a W register or data memory location into a destination W register.

3.8.2. BFINS

This instruction can insert multiple bits from a source W register or an 8-bit literal value into a W register or data memory location.

In both instructions, the location and width of the bit field within the target word are defined as literal values within the instruction.

3.9. Software Stack Pointer and Frame Pointer

3.9.1. Software Stack Pointer

The dsPIC33A devices feature a software stack which facilitates function calls and exception handling. W15 is the default Stack Pointer (SP) and after any reset, it is initialized to 0x4000. This ensures that the SP will point to valid RAM and permits stack availability for exceptions, which may occur before the SP is set by the user software. The user may reprogram the SP during initialization to any location within data space.

The SP always points to the first available free word at TOS (Top-of-Stack) and fills the software stack, working from lower addresses towards higher addresses. It pre-decrements for a stack POP (read) and post-increments for a stack PUSH (write).

The software stack is manipulated using the PUSH and POP instructions. The PUSH and POP instructions are the equivalent of a MOV instruction with W15 used as the destination pointer. For example, the contents of W0 can be PUSHed onto the TOS by:

```
PUSH.L W0
```

This syntax is equivalent to:

```
MOV.L W0, [W15++]
```

The contents of the TOS can be returned to W0 by:

```
POP.L W0
```

This syntax is equivalent to:

```
MOV.L [--W15], W0
```

During any CALL instruction, the PC is PUSHed onto the stack, such that when the subroutine completes execution, program flow may resume from the correct location. When the PC is PUSHed onto the stack, the Most Significant Byte of PC is zero-extended, as shown in [Figure 3-3](#). During exception processing, the Most Significant seven bits of the PC are concatenated with the lower byte of the STATUS Register (SRL) and IPL[3] (CORCON[3]). This allows the primary STATUS Register contents and CPU Interrupt Priority Level to be automatically preserved during interrupts.

Note: In order to protect against misaligned stack accesses, W15[0] is always clear.

Figure 3-3. Stack Operation for CALL Instruction

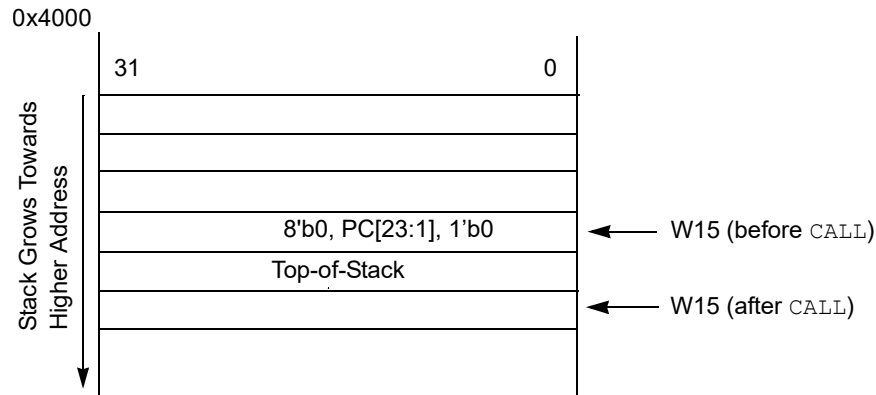

3.9.1.1. Stack Pointer Example

Figure 3-4 through Figure 3-7 show how the software stack is modified for the code snippet shown in Example 3-13. Figure 3-4 shows the software stack before the first PUSH has executed. Note that the SP has the initialized value of 0x4000. Furthermore, the example loads 0x5A5A and 0x3636 to W0 and W1, respectively. The stack is PUSHed for the first time in Figure 3-5 and the value contained in W0 is copied to TOS. W15 is automatically updated to point to the next available stack location and the new TOS is 0x4004. In Figure 3-6, the contents of W1 are PUSHed onto the stack and the new TOS becomes 0x4008. In Figure 3-7, the stack is POPped, which copies the last PUSHed value (W1) to W3. The SP is decremented during the POP operation and at the end of the example, the final TOS is 0x4004.

Figure 3-4. Stack Pointer Before the First PUSH

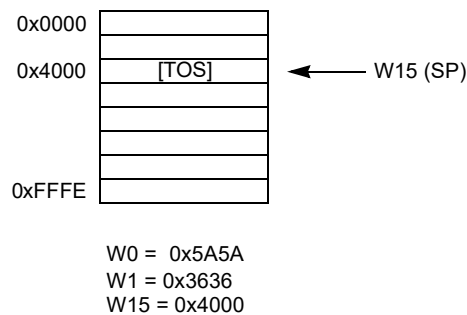

Figure 3-5. Stack Pointer After "PUSH.L W0" Instruction

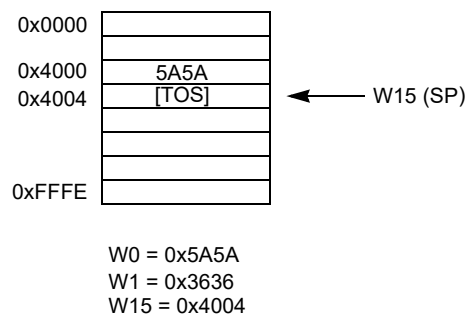

Figure 3-6. Stack Pointer After “PUSH.L W1” Instruction

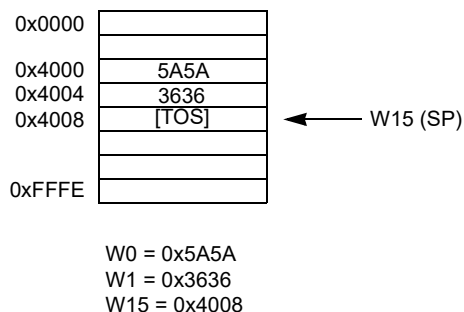
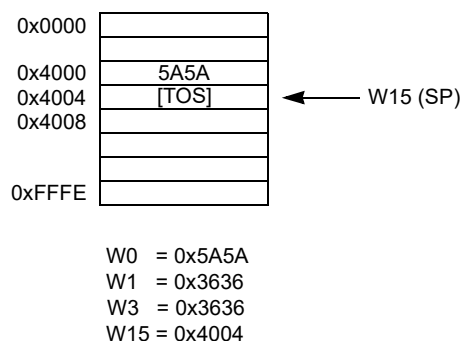

Figure 3-7. Stack Pointer After “POP.L W3” Instruction

**Example 3-13. Stack Pointer Usage**

```

MOV      #0x5A5A, W0      ; Load W0 with 0x5A5A
MOV      #0x3636, W1      ; Load W1 with 0x3636
PUSH.L   W0               ; Push W0 to TOS
PUSH.L   W1               ; Push W1 to TOS
POP.L    W3               ; Pop TOS to W3

```

3.9.2. Software Stack Frame Pointer

A stack frame is a user-defined section of memory residing in the software stack. It is used to allocate memory for temporary variables, which a function uses, and one stack frame may be created for each function. W14 is the default Stack Frame Pointer (FP) and it is initialized to 0x0000 on any reset. If the Stack Frame Pointer is not used, W14 may be used like any other Working register.

The Link (LNK) and Unlink (ULNK) instructions provide stack frame functionality. The LNK instruction is used to create a stack frame. It is used during a call sequence to adjust the SP, such that the stack may be used to store temporary variables utilized by the called function. After the function completes execution, the ULNK instruction is used to remove the stack frame created by the LNK instruction. The LNK and ULNK instructions must always be used together to avoid stack overflow.

3.9.2.1. Stack Frame Pointer Example

Figure 3-8 through Figure 3-10 show how a stack frame is created and removed for the code snippet shown in Example 3-14. This example demonstrates how a stack frame operates and is not indicative of the code generated by the compiler. Figure 3-8 shows the stack condition at the beginning of the example, before any registers are pushed to the stack. Here, W15 points to the first free stack location (TOS) and W14 points to a portion of stack memory allocated for the routine that is currently executing.

Before calling the function, "COMPUTE", the parameters of the function (W0, W1 and W2) are PUSHed on the stack. After the "CALL COMPUTE" instruction is executed, the PC changes to the address of "COMPUTE" and the return address of the function, "TASKA", is placed on the stack (Figure 3-9). Function "COMPUTE" then uses the "LNK #4" instruction to PUSH the calling routine's Frame Pointer value onto the stack and the new Frame Pointer will be set to point to the current Stack Pointer. Then, the literal 4 is added to the Stack Pointer address in W15, which reserves memory for two long-word of temporary data (Figure 3-10).

Inside the function, "COMPUTE", the FP is used to access the function parameters and temporary (local) variables. [W14 + n] will access the temporary variables used by the routine and [W14 - n] is used to access the parameters. At the end of the function, the ULNK instruction is used to copy the Frame Pointer address to the Stack Pointer and then POP the calling subroutine's Frame Pointer back to the W14 register. The ULNK instruction returns the stack back to the state shown in Figure 3-9.

A RETURN instruction will return to the code that called the subroutine. The calling code is responsible for removing the parameters from the stack. The RETURN and POP instructions restore the stack to the state shown in Figure 3-8.

Figure 3-8. Stack at the Beginning of Frame Pointer Usage Example

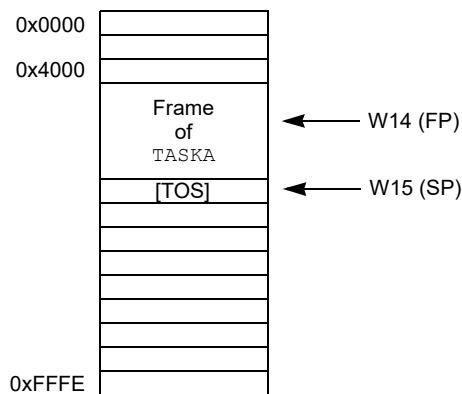

Figure 3-9. Stack After "CALL COMPUTE" Executes

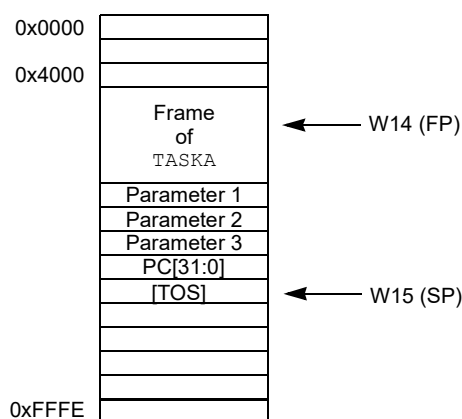
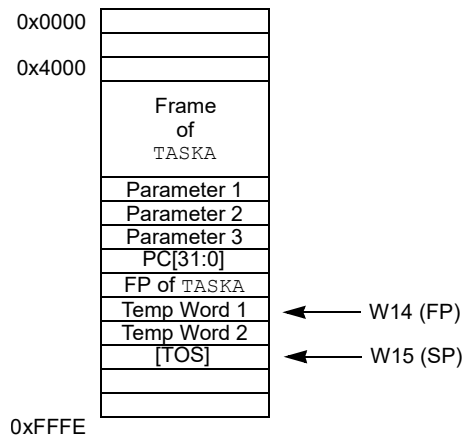

Figure 3-10. Stack After “LNK #4” Executes

**Example 3-14. Frame Pointer Usage**

```

TASKA:    ...
          PUSH W0      ; Push parameter 1
          PUSH W1      ; Push parameter 2
          PUSH W2      ; Push parameter 3
          CALL COMPUTE ; Call COMPUTE function
          POP W2       ; Pop parameter 3
          POP W1       ; Pop parameter 2
          POP W0       ; Pop parameter 1
          ...

COMPUTE:
  LNK #4      ; Stack FP, allocate 4 bytes for local variables
  ...
  ULNK       ; Free allocated memory, restore original FP
  RETURN     ; Return to TASKA

```

3.9.3. Stack Pointer Overflow

There is a Stack Limit register (SPLIM) associated with the Stack Pointer that is reset to 0x00000000. SPLIM is a 32-bit register, but SPLIM[1:0] is fixed to '00', because all stack operations must be long word-aligned. To match the Stack Pointer, the device address space is limited to 24-bits, so the upper 8-bits of SPLIM are always all 0.

The stack overflow check will not be enabled until a word write to SPLIM occurs, after which time it can only be disabled by a device reset. All Effective Addresses generated using W15 as a source or destination are compared against the value in SPLIM. Should the Effective Address be greater than the contents of SPLIM, then a stack error trap is generated.

If stack overflow checking has been enabled, a stack error trap will also occur if the W15 Effective Address calculation wraps over the end of data space (0x00FFFFFF).

3.9.4. Stack Pointer Underflow

The stack is initialized to 0x4000 during reset. A stack error trap will be initiated should the Stack Pointer address ever be less than 0x4000.

3.10. Conditional Branch Instructions

Conditional branch instructions are used to direct program flow based on the contents of the STATUS Register. These instructions are generally used in conjunction with a compare class instruction, but they may be employed effectively after any operation that modifies the STATUS Register.

The compare instructions, `CP`, `CP0` and `CPB`, perform a subtract operation (minuend – subtrahend), but do not actually store the result of the subtraction. Instead, compare instructions just update the flags in the STATUS Register, such that an ensuing conditional branch instruction may change program flow by testing the contents of the updated STATUS Register. If the result of the STATUS Register test is true, the branch is taken. If the result of the STATUS Register test is false, the branch is not taken.

The supported conditional branch instructions are shown in [Table 3-8](#). This table identifies the condition in the STATUS Register that must be true for the branch to be taken. In some cases, just a single bit is tested (as in `BRA C`), while in other cases, a complex logic operation is performed (as in `BRA GT`). Both signed and unsigned conditional tests are supported, and support is provided for DSP algorithms with the `OA`, `OB`, `SA` and `SB` condition mnemonics.

Table 3-8. Conditional Branch Instructions

Condition Mnemonic ⁽¹⁾	Description	Status Test
C	Carry (not Borrow)	C
GE	Signed Greater Than or Equal	$(\bar{N} \& \bar{OV}) \mid \mid (N \& OV)$
GEU ⁽²⁾	Unsigned Greater Than or Equal	C
GT	Signed Greater Than	$(Z \& \bar{N} \& \bar{OV}) \mid \mid (Z \& N \& OV)$
GTU	Unsigned Greater Than	$C \& \bar{Z}$
LE	Signed Less Than or Equal	$Z \mid \mid (\bar{N} \& OV) \mid \mid (N \& \bar{OV})$
LEU	Unsigned Less Than or Equal	$\bar{C} \mid \mid Z$
LT	Signed Less Than	$(\bar{N} \& OV) \mid \mid (N \& \bar{OV})$
LTU ⁽³⁾	Unsigned Less Than	C
N	Negative	N
NC	Not Carry (Borrow)	C
NN	Not Negative	N
NOV	Not Overflow	OV
NZ	Not Zero	Z
OA	Accumulator A Overflow	OA
OB	Accumulator B Overflow	OB
OV	Overflow	OV
SA	Accumulator A Saturate	SA
SB	Accumulator B Saturate	SB
Z	Zero	Z

Notes:

1. Instructions are of the form: `BRA mnemonic, Expr`.
2. `GEU` is identical to `C` and will reverse assemble to `BRA C, Expr`.
3. `LTU` is identical to `NC` and will reverse assemble to `BRA NC, Expr`.

Note: The “Compare and Skip” instructions (`CPBEQ`, `CPBGT`, `CPBLT`, `CPBNE`, `CPSEQ`, `CPSGT`, `CPSLT` and `CPSNE`) do not modify the STATUS Register.

3.10.1. Floating Point Branch Instruction

Subsequent to floating point `CPS/CPQ` instructions setting one of the FSR ordering relations status bits, a subsequent floating point conditional branch (`FBRA`) instruction will (indirectly) examine these status bits, applying them to a logical predicate that represents the required condition. A list of the supported floating point branches and corresponding predicates is shown in [Table 3-9](#).

Table 3-9. FPU Conditional Branch Instruction

Condition Mnemonic ⁽¹⁾	Description	Status test
EQ	Equal	FSR.EQ
UNE	Unordered or Not Equal	(FSR.GT FSR.LT FSR.UN)
NE	Not Equal	(FSR.GT FSR.LT)
UEQ	Unordered or Equal	(FSR.EQ FSR.UN)
GT	Greater Than	FSR.GT
ULE	Unordered or Less Than or Equal	(FSR.LT FSR.EQ FSR.UN)
GE	Greater Than or Equal	(FSR.GT FSR.EQ)
ULT	Unordered or Less Than	(FSR.LT FSR.UN)
LT	Less Than	FSR.LT
UGE	Unordered or Greater Than or Equal	(FSR.GT FSR.EQ FSR.UN)
LE	Less Than or Equal	(FSR.LT FSR.EQ)
UGT	Unordered or Greater Than	(FSR.GT FSR.UN)
OR	Ordered	(FSR.GT FSR.LT FSR.EQ)
UN	Unordered	FSR.UN

Note:

- Instructions are of the form: FBRA mnemonic, Expr.

3.11. Z Status Bit

The Z Status bit is a special Zero Status bit that is useful for extended precision arithmetic. The Z bit functions like a normal Z flag for all instructions, except those that use the Carry/Borrow input (ADDC, CPB, SUBB and SUBBR). For the ADDC, CPB, SUBB and SUBBR instructions, the Z bit can only be cleared and never set. If the result of one of these instructions is non-zero, the Z bit will be cleared and will remain cleared, regardless of the result of subsequent ADDC, CPB, SUBB or SUBBR operations. This allows the Z bit to be used for performing a simple zero check on the result of a series of extended precision operations.

A sequence of instructions working on multiprecision data (starting with an instruction with no Carry/Borrow input) will automatically logically AND the successive results of the zero test. All results must be zero for the Z flag to remain set at the end of the sequence of operations. If the result of the ADDC, CPB, SUBB or SUBBR instruction is non-zero, the Z bit will be cleared and remain cleared for all subsequent ADDC, CPB, SUBB or SUBBR instructions.

3.12. DSP Data Formats

3.12.1. Integer and Fractional Data

The DSP engine supports both integer and fractional data types. Integer data is inherently represented as a signed two's complement value, where the MSb is defined as a Sign bit. Generally speaking, the range of an N-bit two's complement integer is -2^{N-1} to $2^{N-1} - 1$. For a 16-bit integer, the data range is -32768 (0x8000) to 32767 (0x7FFF), including '0'. For a 32-bit integer, the data range is -2,147,483,648 (0x8000 0000) to 2,147,483,647 (0x7FFF FFFF).

Fractional data is represented as a two's complement number, where the MSb is defined as a Sign bit and the radix point is implied to lie just after the Sign bit. This format is commonly referred to as 1.15 (or Q15) format, where 1 is the number of bits used to represent the integer portion of the number and 15 is the number of bits used to represent the fractional portion. The range of an N-bit two's complement fraction with this implied radix point is -1.0 to $(1 - 2^{1-N})$. For a 16-bit fraction, the 1.15 data range is -1.0 (0x8000) to 0.999969482 (0x7FFF), including 0.0 and it has a precision of 3.05176×10^{-5} . In Normal Saturation mode, the 32-bit accumulators use a 1.31 format, which enhances the precision to 4.6566×10^{-10} . In Fractional mode, the 32x32-bit dsPIC33A multiplier generates a Q1.63 product, which has a precision of 1.08420×10^{-19} .

The dynamic range of the accumulators can be expanded by using the eight bits of the Upper Accumulator register (ACCxU) as Guard bits. Guard bits are used if the value stored in the accumulator overflows beyond the 62nd bit and they are useful for implementing DSP algorithms. This mode is enabled when the ACCSAT bit (CORCON[4]) is set to '1' and it expands the accumulators to 72 bits. The Guard bits are also used when the accumulator saturation is disabled. The accumulators then support an integer range of -2^{71} (0x80 0000 0000 0000 0000) to 2^{71-1} (0x7F FFFF FFFF FFFF FFFF). In Fractional mode, the Guard bits of the accumulator do not modify the location of the radix point and the 72-bit accumulators use a 9.63 fractional format. Note that all fractional operation results are stored in the 72-bit accumulator, justified with a 1.63 radix point. As in Integer mode, the Guard bits merely increase the dynamic range of the accumulator. 9.63 fractions have a range of -256.0 (0x80 0000 0000 0000 0000) to $256.0 - 1.08420 \times 10^{-19}$ (0x7F FFFF FFFF FFFF FFFF).

Table 3-10 identifies the range and precision of integers and fractions on 16-bit, 32-bit and 72-bit registers.

With the exception of DSP multiplies, the ALU operates identically on integer and fractional data. Namely, an addition of two integers will yield the same result (binary number) as the addition of two fractional numbers. The only difference is how the result is interpreted by the user. However, multiplies performed by DSP operations are different. In these instructions, data format selection is made by the IF bit (CORCON[0]) and it must be set accordingly ('0' for Fractional mode, '1' for Integer mode). This is required because of the implied radix point used by fractional numbers.

Table 3-10. dsPIC33A Data Ranges

Register Size	Integer Range	Fraction Range	Fraction Resolution
16-bit	-32768 to 32767	-1.0 to $(1.0 - 2^{-15})$	3.052×10^{-5}
32-bit	-2,147,483,648 to 2,147,483,647	-1.0 to $(1.0 - 2^{-31})$	4.657×10^{-10}
72-bit	-2^{71} to 2^{71}	-256.0 to $256.0 - 1.08420 \times 10^{-19}$	1.08420×10^{-19}

3.12.2. Integer and Fractional Data Representation

Both integer and fractional data treat the MSb as a Sign bit, and the binary exponent decreases by one as the bit position advances toward the LSb. The binary exponent for an N-bit integer starts at (N-1) for the MSb and ends at '0' for the LSb. For an N-bit fraction, the binary exponent starts at '0' for the MSb and ends at (1-N) for the LSb (as shown in [Figure 3-11](#) for a positive value and in [Figure 3-12](#) for a negative value).

Conversion between integer and fractional representations can be performed using simple division and multiplication. To go from an N-bit integer to a fraction, divide the integer value by 2^{N-1} . Similarly, to convert an N-bit fraction to an integer, multiply the fractional value by 2^{N-1} .

Figure 3-11. Different Representations of 0x4001

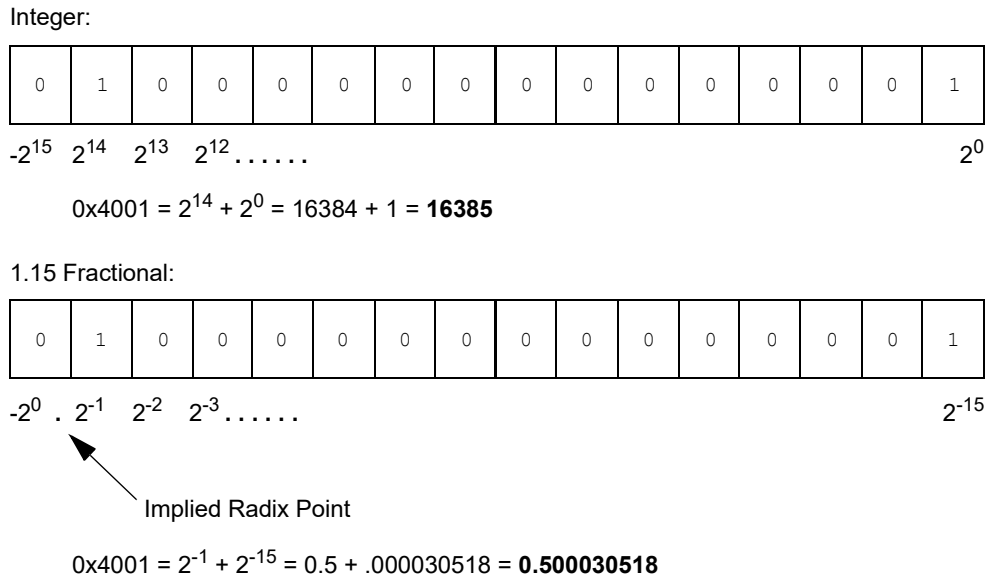
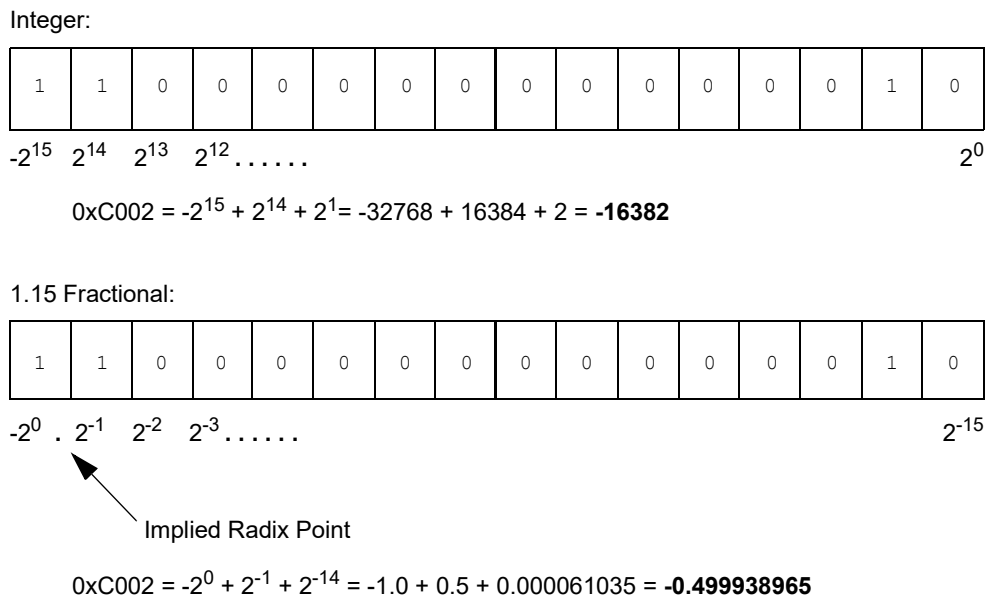

Figure 3-12. Different Representations of 0xC002



3.13. Accumulator Usage

Accumulators A and B are utilized by DSP instructions to perform mathematical and shifting operations. Since the accumulators are 72-bits wide and the X and Y data paths are only 32 bits, the method to load and store the accumulators must be understood.

Item A in [Figure 3-13](#) shows that each 72-bit accumulator (ACCA and ACCB) consists of an 8-bit upper register (ACCxU), a 32-bit high register (ACCxH) and a 32-bit low register (ACCxL). To address the bus alignment requirement and provide the ability for 1.31 math, ACCxH is used as a destination register for loading the accumulator (with the LAC instruction) and also as a source register for storing the accumulator (with the SACR instruction). This is represented by Item B in [Figure 3-13](#), where the upper and lower portions of the accumulator are shaded. In reality, during accumulator

loads, ACCxL is zero backfilled and ACCxU is sign-extended to represent the sign of the value loaded in ACCxH.

Note: dsPIC33A devices provide SUAC, SAC and SLAC instructions to store ACCxU, ACCxH and ACCxL values respectively. Similarly, LUAC, LAC and LLAC instructions can be used to load values to ACCxU, ACCxH and ACCxL.

When normal (63-bit) saturation is enabled, DSP operations (such as `ADD`, `MAC`, `MSC`, etc.) solely utilize ACCxH:ACCxL (item C in [Figure 3-13](#)) and ACCxU is only used to maintain the sign of the value stored in ACCxH:ACCxL. For instance, when an `MPY` instruction is executed, the result is stored in ACCxH:ACCxL, and the sign of the result is extended through ACCxU.

When super saturation is enabled, or when saturation is disabled, all registers of the accumulator may be used (item D in [Figure 3-13](#)), and the results of DSP operations are stored in ACCxU:ACCxH:ACCxL. The benefit of ACCxU is that it increases the dynamic range of the accumulator, as described in [Integer and Fractional Data](#). Refer to [Table 3-10](#) to see the range of values which may be stored in the accumulator when in Normal and Super Saturation modes.

Figure 3-13. Accumulator Alignment and Usage

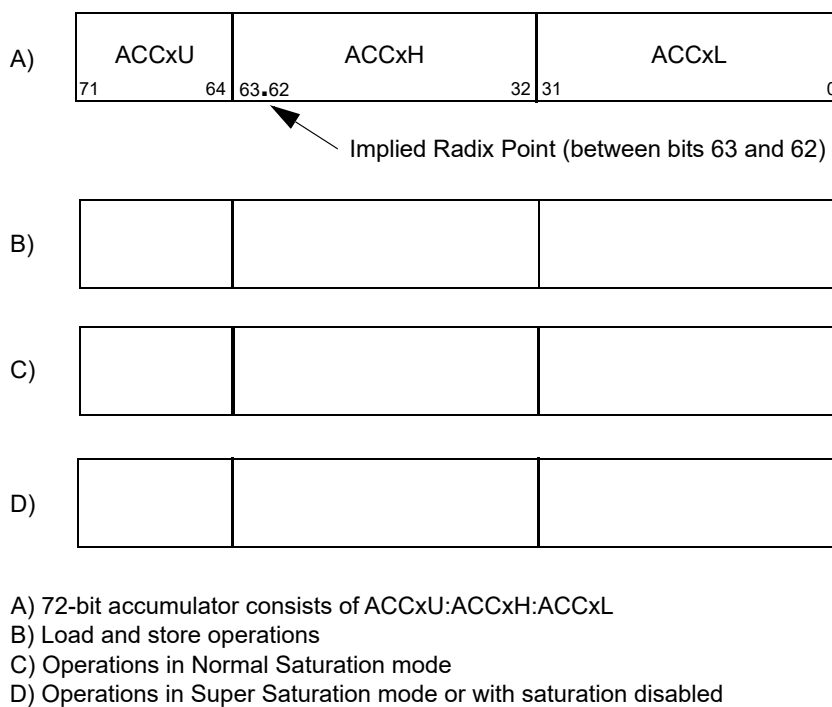

3.14. Accumulator Access

Accumulator can be accessed with File Register or Indirect Addressing, using any instruction which supports such addressing. However, it is recommended that the DSP instructions, `LAC`, `SAC` and `SACR`, be used to load and store the accumulators, since they provide sign-extension, shifting and rounding capabilities. `LAC`, `SAC`, and `SACR` instruction details are provided in [Instruction Descriptions](#).

Notes:

1. For convenience, ACCAU and ACCBU are sign-extended to 32 bits. This provides the flexibility to access these registers using either Byte or Word mode (when File Register or Indirect Addressing is used).
2. The OA, OB, SA or SB bit cannot be set by writing overflowed values to the memory-mapped accumulators using MOV instructions, as these Status bits are only affected by DSP operations.
3. dsPIC33A SUAC, SAC and SLAC instructions to store ACCxU, ACCxH and ACCxL values respectively. Similarly, LUAC, LAC and LLAC instructions can be used to load values to ACCxU, ACCxH and ACCxL.

3.15. DSP MAC Instructions

The DSP Multiply and Accumulate (MAC) operations are a special suite of instructions that provide the most efficient use of the dsPIC33A architectures. The DSP MAC instructions, shown in [Table 3-11](#), utilize both the X and Y data paths of the CPU core.

MAC instructions are also capable of performing an operation with one accumulator, while storing out the rounded contents of the alternate accumulator. This feature is called Accumulator Write-Back (WB) and it provides flexibility for the software developer. For instance, the Accumulator WB may be used to run two algorithms concurrently or efficiently process complex numbers, among other things.

Table 3-11. DSP MAC Instructions

Instruction	Description
ED	Euclidean Distance (No Accumulate)
EDAC	Euclidean Distance
MAC	Multiply and Accumulate
SQRAC	Square and Accumulate
MPY	Multiply to Accumulator
MPY.N	Negative Multiply to Accumulator
MSC	Multiply and Subtract from Accumulator
SQRSC	Square and Subtract from Accumulator
SQR	Square to Accumulator
SQRN	Negated Square to Accumulator

3.15.1. MAC Operations

The mathematical operations performed by the MAC class of DSP instructions center around multiplying or squaring the contents of two Working registers and either adding, subtracting or storing the result to either Accumulator A or Accumulator B. This is the operation of the MAC, MPY, MPY.N, MSC, SQR, SQRAC, SQRSC and SQRN instructions.

For the ED and EDAC instructions, the same multiplicand operand must be specified by the instruction because this is the definition of the Euclidean Distance operation.

3.15.2. Rounding Modes

The accumulator stores the instruction SACR, and all AWB write operations can operate with one of two different accumulator rounding modes. The rounding function, either conventional (biased) or convergent (unbiased), is applied during the accumulator write (store). The rounding mode is selected by CORCON.RND.

Conventional (biased) rounding examines bit 31 (for long word sized data op) or bit 47 (for word sized data op) of the 72-bit accumulator, zero extends it, and adds it to the MS portion of the accumulator. Consequently, if the LS word of the accumulator is between 32'h8000000 and 32'hFFFFFFF (for long word sized data op) or 48'h800000000000 and 48'hFFFFFFFFF (for word

sized data op), the MS portion of the accumulator will be incremented. Alternatively, if the LS word of the accumulator is between 0x00000000 and 32'h7FFFFFFF (long word sized data op) or 48'h000000000000 and 48'h7FFFFFFF (word sized data op), the MS portion of the accumulator is left unchanged. A consequence of this algorithm is that over a succession of random rounding operations, the value will tend to be biased slightly positive.

Convergent (or unbiased) rounding operates in the same manner as conventional rounding, except when the LS word equals 32'h80000000 (for long word sized data op) or 48'h800000000000 (for word sized data op). If this is the case, the LS-bit of the MS portion of the accumulator (that is, bit 32 or bit 48) is examined. If it is 1, the MS-portion of the accumulator is incremented. If it is 0, the MS portion of the accumulator is not modified.

Assuming that the bit examined is effectively random in nature, this scheme removes any rounding bias that may accumulate.

The two rounding modes are defined in the following tables for each operand (and accumulator write) size. The rounding block will round based on the contents of AccX[31:0] (Long word round) or AccX[47:0] (Word round) depending upon the data size selected for the instruction.

Table 3-12. Rounding Operation (Long Word Operands and AWB Write)

ACCx[31:0] Value	Increment ACCx[71:32]?			
	Convergent		Biased	
	ACCx[32] = 0	ACCx[32] = 1	ACCx[32] = 0	ACCx[32] = 1
ACCx[31] = 0	No	No	No	No
ACCx[31:0] = 32'h80000000	No	Yes	Yes	Yes
ACCx[31] = 1	Yes	Yes	Yes	Yes

Table 3-13. Rounding Operation (Word Operands and AWB Write)

ACCx[31:0] Value	Increment ACCx[71:48]?			
	Convergent		Biased	
	ACCx[48] = 0	ACCx[48] = 1	ACCx[48] = 0	ACCx[48] = 1
ACCx[47] = 0	No	No	No	No
ACCx[47:0] = 48'h800000000000	No	Yes	Yes	Yes
ACCx[47] = 1	Yes	Yes	Yes	Yes

3.15.3. MAC Write-Back

The Write-Back ability of the MAC class of DSP instructions facilitates efficient processing of algorithms. This feature allows one mathematical operation to be performed with one accumulator and the rounded contents of the other accumulator to be stored in the same cycle.

The following addressing modes are supported:

- W0, W1, W2, W3, W13 or W14 register direct: the rounded contents of the non-target accumulator are written into the destination register as a 1.15 (Word mode) or 1.31 (Long Word mode) fraction. As is the case for any register direct word write, the value written is zero extended to 32-bits prior to being written into the destination WREG.
- [W13++] or [W15++] register indirect with post increment: the rounded contents of the non-target accumulator are written into the address pointed to by W13 or W15 as a 1.15 (Word mode) or 1.31 (Long Word mode) fraction. The destination EA W-reg is then incremented by two (for a word write) or four (for a long word write).

3.15.4. MAC Syntax

The syntax of the MAC class of instructions can have several formats, which depend on the instruction type and the operation it is performing with respect to prefetches and Accumulator

Write-Back. All MAC class instructions must specify a target accumulator along with two multiplicands, as shown in [Example 3-15](#).

If an Accumulator Write-Back is used in the instruction, it is specified last. By definition, the accumulator not used in the mathematical operation is stored, so the Write-Back accumulator is not specified in the instruction. Legal forms of Accumulator Write-Back (WB) are shown in [Example 3-16](#).

Example 3-15. Base MAC Syntax

```
; MAC with no prefetch
MAC W4,W5, A
```

```
; MAC with no prefetch
MAC W7,W7, B
```

→ Multiply W7*W7, Accumulate to ACCB

Example 3-16. MAC Accumulator WB Syntax

```
; MAC with indirect WB of ACCB
```

```
MAC W4,W5, A
```

```
W13++
```

→ ACCA=ACCA+W4*W5

→ ACCB → [W13] +=2

3.16. DSP Accumulator Instructions

The DSP accumulator instructions provide the ability to add, negate, shift, load and store the contents of either 72-bit accumulator. In addition, the ADD and SUB instructions allow the two accumulators to be added or subtracted from each other. DSP accumulator instructions are shown in [Table 3-14](#) and instruction details are provided in [Instruction Descriptions](#).

Table 3-14. DSP Accumulator Instructions

Instruction	Description	Accumulator WB?
ADD	Add Accumulators	No
ADD	16-Bit Signed Accumulator Add	No
LAC	Load Accumulator	No
LUAC	Load upper accumulator (ACCxU)	No
LLAC	Load lower accumulator (ACCxL)	No
NEG	Negate Accumulator	No
SAC	Store Accumulator	No
SUAC	Store upper accumulator (ACCxU)	No
SLAC	Store lower accumulator (ACCxL)	No
SACR	Store Rounded Accumulator	No
SFTAC	Arithmetic Shift Accumulator by Literal	No
SFTAC	Arithmetic Shift Accumulator by (Wn)	No
SUB	Subtract Accumulators	No

3.17. Scaling Data with the FBCL Instruction

To minimize quantization errors that are associated with data processing using DSP instructions, it is important to utilize the complete numerical result of the operations. This may require scaling data up to avoid underflow (i.e., when processing data from a 12-bit ADC) or scaling data down to avoid overflow (i.e., when sending data to a 10-bit DAC). The scaling, which must be performed to minimize quantization error, depends on the dynamic range of the input data which is operated on and the required dynamic range of the output data. At times, these conditions may be known beforehand and fixed scaling may be employed. In other cases, scaling conditions may not be fixed or known and then dynamic scaling must be used to process data.

The FBCL instruction (Find First Bit Change Left) can efficiently be used to perform dynamic scaling, because it determines the exponent of a value. A fixed point or integer value's exponent represents the amount that the value may be shifted before overflowing. This information is valuable because it may be used to bring the data value to "full scale", meaning that its numeric representation utilizes all the bits of the register it is stored in.

The FBCL instruction determines the exponent of a word by detecting the first bit change, starting from the value's Sign bit and working towards the LSB. Since the dsPIC33A device's barrel shifter uses negative values to specify a left shift, the FBCL instruction returns the negated exponent of a value. If the value is being scaled up, this allows the ensuing shift to be performed immediately with the value returned by FBCL. Additionally, since the FBCL instruction only operates on signed quantities, FBCL produces results in the range of -15:0 for word operation and -31:0 for long word operation. When the FBCL instruction returns 0, it indicates that the value is already at full scale. When the instruction returns -31, it indicates that the value cannot be scaled (as is the case with 0x0 and 0xFFFFFFFF). [Table 3-15](#) shows word data with various dynamic ranges, their exponents and the value after scaling the data to maximize the dynamic range. [Example 3-17](#) shows how the FBCL instruction may be used for block processing.

Table 3-15. Scaling Examples

Word Value	Exponent	Full-Scale Value (Word Value << Exponent)
0x0001	14	0x4000
0x0002	13	0x4000
0x0004	12	0x4000
0x0100	6	0x4000
0x01FF	6	0x7FC0
0x0806	3	0x4030
0x2007	1	0x400E
0x4800	0	0x4800
0x7000	0	0x7000
0x8000	0	0x8000
0x900A	0	0x900A
0xE001	2	0x8004
0xFF07	7	0x8380

Note: For the word values, 0x0000 and 0xFFFF, the FBCL instruction returns -15.

As a practical example, assume that block processing is performed on a sequence of data with very low dynamic range stored in 1.15 fractional format. To minimize quantization errors, the data may be scaled up to prevent any quantization loss that may occur as it is processed. The FBCL instruction can be executed on the sample with the largest magnitude to determine the optimal scaling value for processing the data. Note that scaling the data up is performed by left shifting the data. This is demonstrated with the code snippet below.

Example 3-17. Scaling with FBCL

```

; assume W0 contains the largest absolute value of the data block
; assume W4 points to the beginning of the data block
; assume the block of data contains BLOCK_SIZE words
; determine the exponent to use for scaling
FBCL    W0, W2                ; store exponent in W2
; scale the entire data block before processing
DO      #(BLOCK_SIZE-1), SCALE
LAC     [W4], A               ; move the next data sample to ACCA
SFTAC   A, W2                 ; shift ACCA by W2 bits
SCALE:
SAC     A, [W4++]             ; store scaled input (overwrite
original)
; now process the data
; (processing block goes here)

```

3.18. Data Range Limit Instructions

The dsPIC33A family provides special instructions that automatically limit the data in a W register or an accumulator to lie within a user-specified numerical range. These include the `FLIM`, `MAX`, `MIN` and `MINZ` instructions.

3.18.1. FLIM/FLIM.V

The `FLIM` instruction simultaneously compares a maximum and a minimum data limit value with the specified W register (or data pointed to by the W register) and clamps the target data to the user-specified limit if the limit is exceeded. SR Status bits are set accordingly for subsequent signed branching. In the `FLIM.V` instruction, an additional W register is specified, in which the limit test result (known as “limit excess”) value is loaded.

3.18.2. MAX/MAX.V

The `MAX` instruction compares a maximum data limit value (stored in a W register or the other accumulator) with the target accumulator and clamps the target accumulator to the user-specified limit if this upper limit is exceeded. SR Status bits are set accordingly for subsequent signed branching. In the `MAX.V` instruction, an additional W register (or W register in Indirect Addressing mode) is specified in which the limit excess value is loaded.

3.18.3. MIN/MIN.V/MINZ

The `MIN` instruction compares a minimum data limit value (stored in a W register or the other accumulator) with the target accumulator and clamps the target accumulator to the user-specified limit if the data is smaller than this minimum limit. SR Status bits are set accordingly for subsequent signed branching. In the `MIN.V` instruction, an additional W register (or W register in Indirect Addressing mode) is specified, in which the limit excess value is loaded. The `MINZ` instruction is simply a conditional version of the `MIN` instruction, which is executed only when `Z = 1`.

3.19. Normalizing the Accumulator with the NORM Instruction

The `NORM` instruction automatically normalizes the target accumulator to obtain the largest fractional value possible without overflow. The target accumulator must contain signed fractional data for the instruction result to be valid. It will shift the target accumulator right or left by as many bits as required to normalize the data, keeping the sign consistent. The shift value is stored in a destination address. The N Status bit reflects the direction of the accumulator shift.

If the accumulator cannot be normalized, the accumulator contents will not be affected.

4. Instruction Descriptions

4.1. Instruction Symbols

All the symbols used in [Instruction Descriptions](#) are listed in [Table 2](#).

4.2. Instruction Encoding Field Descriptors Introduction

All instruction encoding field descriptors used in [Instruction Descriptions](#) are shown in [Table 4-2](#) through [Table 4-10](#).

Table 4-1. Instruction Encoding Field Descriptors

Field	Description
A	Accumulator Selection bit: 0 = ACCA; 1 = ACCB
aaa	Accumulator Write Back mode (see Table 4-9)
B	Byte Mode Selection bit: 0 = word operation; 1 = byte operation
bbb	3-bit bit position select: 000 = LSB; 111 = MSB
bbbb	5-bit bit position select: 00000 = LSB; 11111 = MSB
cccc	Bit field instructions LSB value
D	Destination Address bit: 0 = result stored in W0; 1 = result stored in file register
dddd	Wd destination register select: 0000 = W0; 1111 = W15
dddddd	Coprocessor destination register select (Fd for FPU where 00000 = F0; 11111 = F31)
E	MULxx Result size: 0 = 32-bit in Wnd; 1 = 64-bit in (Wnd+1, Wnd)
F	Selects between W15 (F = 0) and W14 (F = 1) registers
(ffff) ffff ffff ffff ffff	16-bit or 20-bit register file address (addressable space varies depending upon instruction class)
G	Bit test destination: 0 = Z flag bit; 1 = C flag bit
I	MULAx Multiplier mode: 0 = Fractional; 1 = Integer
IIIIi	X data fetch operation
JJJjj	Y data fetch operation
k	1-bit literal field, constant data
kkk	3-bit literal field, constant data
k kkkk	5-bit literal field, constant data
kk kkkk	6-bit literal field, constant data
kkkk kkkk	8-bit literal field, constant data
kkkk kkkk kkkk kkkk	16-bit literal field, constant data
kkkk kkkk kkkk kkkk kkkk kkkk kkkk kkkk	32-bit literal field, constant data
L	Long (32-bit) Mode Selection bit: 0 = word or byte operation; 1 = long operation
mmmmmm	Bit field instructions MSb value
nnnn nnnn nnnn nnnn nnnn n	21-bit signed instruction word offset field for relative branch/call instructions
nnnn nnnn nnnn nn00 nnnn nnnn	24-bit program address for goto/call instructions
ppp	Addressing mode for Ws source register (see Table 4-2)
qqq	Addressing mode for Wd destination register (see Table 4-3)
R	Selects between FPU coprocessor special registers or F-regs
rrr	Condition select for conditional move (MOVIF) instruction

Table 4-1. Instruction Encoding Field Descriptors (continued)

Field	Description
S	Opcode size select (16-bit: S = 0; 32-bit: S = 1)
ssss	Ws source or Wn source/destination register select: 0000 = W0; 1111 = W15
sssss	Coprocessor source register select (Fs for FPU where 00000 = F0; 11111 = F31)
T	Selects between Ws (T = 0) and SR (T = 1) target registers
U	Unused (don't care) Instruction bit. Assembler to assign '0'
V	FLIMW: Selects result format for Wnd (refer to instruction description) MULxx: Selects between unsigned Ws (V = 0) and signed Ws (V = 1).
W	Destination write control: 0 = Wd write not required; 1 = Wd write required
www	Source Wb base register select: 0000 = W0; 1111 = W15
zz	Coprocessor select

Table 4-2. Addressing Modes for Ws Source Register

ppp	Addressing Mode	Source Operand
000	Register Direct	Wns
001	Indirect	[Ws]
010	Indirect with Post-Decrement	[Ws--]
011	Indirect with Post-Increment	[Ws++]
100	Indirect with Pre-Decrement	[--Ws]
101	Indirect with Pre-Increment	[++Ws]
110	Status Register Direct	SR (Source)
111	Indirect with Register Offset	[Ws+Wb]

Table 4-3. Addressing Modes for Wd Destination Register

ddd	Addressing Mode	Destination Operand
000	Register Direct	Wnd
001	Indirect	[Wd]
010	Indirect with Post-Decrement	[Wd--]
011	Indirect with Post-Increment	[Wd++]
100	Indirect with Pre-Decrement	[--Wd]
101	Indirect with Pre-Increment	[++Wd]
110	Status Register (SR) Direct	SR (Destination)
111	Indirect with Register Offset	[Wd+Wb]

Table 4-4. Destination Addressing Modes for MCU Multiplications

dddd	Destination
0000	W1:W0
0001	W0
0010	W3:W2
0011	W2
0100	W5:W4
0101	W4
0110	W7:W6
0111	W6
1000	W9:W8
1001	W8
1010	W11:W10

Table 4-4. Destination Addressing Modes for MCU Multiplications (continued)

ddd	Destination
1011	W10
1100	W13:W12
1101	W12
1110	ACCA[39:0]
1111	ACCB[39:0]

Table 4-5. Offset Addressing Modes for Ws Source Register (with Register Offset)

ggg	Addressing Mode	Source Operand
000	Register Direct	Ws
001	Indirect	[Ws]
010	Indirect with Post-Decrement	[Ws--]
011	Indirect with Post-Increment	[Ws++]
100	Indirect with Pre-Decrement	[--Ws]
101	Indirect with Pre-Increment	[++Ws]
11x	Indirect with Register Offset	[Ws+Wb]

Table 4-6. Offset Addressing Modes for Wd Destination Register (with Register Offset)

hhh	Addressing Mode	Source Operand
000	Register Direct	Wd
001	Indirect	[Wd]
010	Indirect with Post-Decrement	[Wd--]
011	Indirect with Post-Increment	[Wd++]
100	Indirect with Pre-Decrement	[--Wd]
101	Indirect with Pre-Increment	[++Wd]
11x	Indirect with Register Offset	[Wd+Wb]

Table 4-7. MAC or MPY Source Operands – Same Working Register

mm	Multiplicands
00	W4 * W4
01	W5 * W5
10	W6 * W6
11	W7 * W7

Table 4-8. MAC or MPY Source Operands – Different Working Register

mmm	Multiplicands
000	W4 * W5
001	W4 * W6
010	W4 * W7
011	Invalid
100	W5 * W6
101	W5 * W7
110	W6 * W7
111	Invalid

Table 4-9. MAC Accumulator Write-Back Selection

aaa	Write-Back Selection
000	W0 = Other Accumulator
001	W1 = Other Accumulator
010	W2 = Other Accumulator
011	W3 = Other Accumulator
100	W13 = Other Accumulator (Direct Addressing)
101	[W13++] = Other Accumulator (Indirect Addressing with Post-Increment)
110	[W15++] = Other Accumulator
111	No Accumulator Write Back

Table 4-10. Accumulator Selection

A	Target Accumulator
0	Accumulator A
1	Accumulator B

4.3. Instruction Description Example

The example description below is for the fictitious instruction, `FOO`. The following example instruction was created to demonstrate how the table fields (syntax, operands, operation, etc.) are used to describe the instructions presented in [Instruction Descriptions](#).

FOO

FOO	The Header field summarizes what the instruction does
Syntax:	The Syntax field consists of an optional label, the instruction mnemonic, any optional extensions which exist for the instruction and the operands for the instruction. Most instructions support more than one operand variant to support the various addressing modes. In these circumstances, all possible instruction operands are listed beneath each other and are enclosed in braces.
Operands:	The Operands field describes the set of values that each of the operands may take. Operands may be accumulator registers, file registers, literal constants (signed or unsigned) or Working registers.
Operation:	The Operation field summarizes the operation performed by the instruction.
Status Affected:	The Status Affected field describes which bits of the STATUS Register are affected by the instruction. Status bits are listed by bit position in descending order.
Encoding:	The Encoding field shows how the instruction is bit encoded. Individual bit fields are explained in the Description field and complete encoding details are provided in Table 5.2 .
Description:	The Description field describes in detail the operation performed by the instruction. A key for the encoding bits is also provided.
Words:	The Words field contains the number of program words that are used to store the instruction in memory.
Cycles:	The Cycles field contains the number of instruction cycles that are required to execute the instruction.
Examples:	The Examples field contains examples that demonstrate how the instruction operates. "Before" and "After" register snapshots are provided, which allow the user to clearly understand what operation the instruction performs.

ADD		Add ACCA to ACCB	
Syntax:	{label:}	ADD	A B
Operands:	none		
Operation:	ACCA + ACCB → ACC(A or B)		
Status Affected:	OA, SA or OB, SB		
Encoding:	0111	001A	UUUU 1000
Description:	Add ACCA to ACCB and write results to selected accumulator. The 'A' bits specify the destination accumulator.		
I-Words:	0.5		
Cycles:	1		

Example:1	ADD	A	;ACCA = ACCA + ACCB
	Before execution		After execution
	ACCA	0x00_1022_2EE1_5 633_9078	ACCA 0x00_3066_9207_9 746_247B
	ACCB	0x00_2044_6326_4 112_9403	ACCB 0x00_2044_6326_4 112_9403

ADD		Signed Add to Accumulator							
Syntax:	{label:}	ADD{.w} Ws,	{ Slit6, }	A					
		ADD.l	[Ws],	B					
			[Ws++]						
			[Ws--]						
			[--Ws],						
			[++Ws],						
			[Ws+Wb],						
Operands:		Ws ∈ [W0 ... W15]; Wb ∈ [W0 ... W15]; Slit6 ∈ [-32 ... +31]							
Operation:		(ACC) + Shift _{Slit6} (Sign-extend(Ws)) → ACC							
Status Affected:		OA, SA or OB, SB							
Encoding:		1100	00AL	www	sss	pppU	UUkk	kkkk	1011
Description:		<p>The operand contained at the Effective Address is assumed to be Q1.15 or Q1.31 fractional data for word and long data operations respectively. The operand is read, then automatically sign-extended and zero-backfilled to create a value the same size as the accumulator. The value is then optionally (arithmetically) shifted before being added to the target accumulator.</p> <p>The 'L' bit selects word or long word operation.</p> <p>The 'A' bit specifies the destination accumulator.</p> <p>The 's' bits specify the source register Ws.</p> <p>The 'p' bits select the source addressing mode.</p> <p>The 'w' bits specify the offset register Wb.</p> <p>The 'k' bits encode the optional operand Slit6 which determines the amount of the accumulator preshift; if the operand Slit6 is absent, the literal bit field is set to all 0's.</p> <p>Note:</p> <ol style="list-style-type: none"> Positive values of operand Slit6 represent arithmetic shift right. Negative values of operand Slit6 represent shift left. This instruction operates in Long or Word mode only. 							
I-Words:		1							
Cycles:		1							

Example:1	ADD	w8, #1, B	;ACCB = (w8>>1):32'b0+ ACCB ;Shift right ACCB by 1
		Before execution	After execution
	w8	0x20446326	w8 0x20446326
	ACCB	0x00_2044_6326_4 112_9403	ACCB 0x00_3066_94B9_4 112_9403

ADDC		Add Wb and Ws with Carry		
Syntax:	{label:}	ADDC.b Wb,	Ws,	Wd
		ADDC.bz	[Ws],	[Wd]
		ADDC{.w}	[Ws++],	[Wd++]
		ADDC.l	[Ws--],	[Wd--]
			[++Ws],	[++Wd]
			[--Ws],	[--Wd]
Operands:		Wb ∈ [W0 ... W15]; Ws ∈ [W0 ... W15]; Wd ∈ [W0 ... W15]		
Operation:		(Wb) + (Ws) + (C) → Wd		
Status Affected:		C, N, OV, Z		
Encoding:		s110	001L	dddd ssss pppq qqww wwUU BU00
Description:		<p>Add the contents of the source register Ws and the contents of the base register Wb and the Carry bit and place the result in the destination register Wd. The Z bit is “sticky” (can only be cleared). The ‘S’ bit selects instruction size. The ‘L’ and ‘B’ bits select operation data width. The ‘s’ bits select the source register. The ‘w’ bits select the base register. The ‘d’ bits select the destination register. The ‘p’ bits select the source addressing mode. The ‘q’ bits select the destination addressing mode.</p>		
I-Words:		1 or 0.5		
Cycles:		1		

Example 1:	ADDC.B	W0,[W1++],[W2++]	; Add W0, [W1] and C bit (Byte mode) ; Store the result in [W2] ; Post-increment W1, W2
------------	--------	------------------	---

Before Instruction		After Instruction	
W0	CC20	W0	CC20
W1	0800	W1	0801
W2	1000	W2	1001
Data 0800	AB25	Data 0800	AB25
Data 1000	FFFF	Data 1000	FF46
SR	0001 (C = 1)	SR	0000

Example 2:	ADDC	W3,[W2++],[W1++]	; Add W3, [W2] and C bit (Word mode) ; Store the result in [W1] ; Post-increment W1, W2
------------	------	------------------	---

Before Instruction		After Instruction	
W1	1000	W1	1002
W2	2000	W2	2002
W3	0180	W3	0180
Data 1000	8000	Data 1000	2681
Data 2000	2500	Data 2000	2500
SR	0001 (C = 1)	SR	0000

ADDC **Add Ws and Short Literal with Carry**

Syntax: {label:} ADDC.b Ws, lit7, Wd
 ADDC.bz [Ws], [Wd]
 ADDC.{w} [Ws++], [Wd++]
 ADDC.l [Ws--], [Wd--]
 [++Ws], [++Wd]
 [--Ws], [--Wd]

Operands: Ws ∈ [W0 ... W15]; lit7 ∈ [0 ... 127]; Wd ∈ [W0 ... W15]

Operation: (Ws) + lit7 + (C) → Wd
 Note: The literal is zero-extended to the selected data size of the operation

Status Affected: C, N, OV, Z

Encoding: 1110 001L dddd ssss pppq qqkk kkkk Bk10

Description: Add the contents of the source register Ws, the zero-extended unsigned literal operand and the Carry bit; place the result in the destination register Wd.
 The Z bit is “sticky” (can only be cleared).
 The ‘L’ and ‘B’ bits select operation data width.
 The ‘k’ bits provide the signed literal operand.
 The ‘s’ bits select the source register.
 The ‘d’ bits select the destination register.
 The ‘p’ bits select the source addressing mode.
 The ‘q’ bits select the destination addressing mode.
Note: Word (.w) and Zero-Extended Byte mode (.bz) mode with a register direct destination will 0 extend the result to 32-bits.

I-Words: 1

Cycles: 1

Example 1: ADDC.B W0, #0x1F, [W7] ; Add W0, 31 and C bit (Byte mode)
 ; Store the result in [W7]

Before Instruction		After Instruction	
W0	CC80	W0	CC80
W7	12C0	W7	12C0
Data 12C0	B000	Data 12C0	B09F
SR	0000 (C = 0)	SR	0008 (N = 1)

Example 2: ADDC W3, #0x6, [--W4] ; Add W3, 6 and C bit (Word mode)
 ; Store the result in [--W4]

Before Instruction		After Instruction	
W3	6006	W3	6006
W4	1000	W4	0FFE
Data 0FFE	DDEE	Data 0FFE	600D
Data 1000	DDEE	Data 1000	DDEE
SR	0001 (C = 1)	SR	0000

ADDC		Add Literal to Wn with Carry	
Syntax:	{label:}	ADDC.b lit16,	Wn
		ADDC.bz	
		ADDC{.w}	
		ADDC.I	
Operands:	lit16 ∈ [0 ... 65535]; Wn ∈ [W0 ... W15]		
Operation:	(Wn) + lit16 + (C) → Wn		
	Note: The literal is zero-extended to the selected data size of the operation		
Status Affected:	C, N, OV, Z		
Encoding:	1100	001L	ssss kkkk kkkk kkkk BU10
Description:	<p>Add the zero-extended literal operand to the contents of the Working register Wn and the Carry bit and place the result in the Working register Wn.</p> <p>The Z bit is "sticky" (can only be cleared).</p> <p>The 'L' and 'B' bits select operation data width.</p> <p>The 's' bits select the Working register.</p> <p>The 'k' bits specify the signed literal operand.</p>		
I-Words:	1		
Cycles:	1		

Example 1: ADDC.B #0xFF, W7 ; Add -1 and C bit to W7 (Byte mode)

Before		After	
Instruction		Instruction	
W7	12C0	W7	12BF
SR	0000 (C = 0)	SR	0009 (N, C = 1)

Example 2: ADDC #0xFF, W1 ; Add 255 and C bit to W1 (Word mode)

Before Instruction		After Instruction	
W1	12C0	W1	13C0
SR	0001 (C = 1)	SR	0000

ADDC		Add f and Carry bit and Wn			
Syntax:	{label:}	ADDC.b	f,	Wn	{,WREG}
		ADDC.bz			
		ADDC{.w}			
		ADDC.I			
Operands:	f ∈ [0 ... 64KB]; Wn ∈ [W0 ... W15]				
Operation:	(f) + (Wn) + (C) → destination designated by D				
Status Affected:	C, N, OV, Z				
Encoding:	1110	001L	ssss	ffff	ffff ffff ffff BD01
Description:	<p>Add the contents of the Working register and the Carry Flag and the contents of the file register and place the result in the destination designated by D. If the optional Wn destination is specified, D=0 and store result in Wn; otherwise, D=1 and store result in the file register. The Z bit is "sticky" (can only be cleared).</p> <p>The 'L' and 'B' bits select operation data width.</p> <p>The 'D' bit selects the destination.</p> <p>The 'f' bits select the address of the file register.</p> <p>The 's' bits select the Working register.</p>				
I-Words:	1				
Cycles:	1				

Example 1: **ADDC.B** **RAM100** **; Add WREG and C bit to RAM100**
; (Byte mode)

Before Instruction				After Instruction			
WREG	CC60			WREG	CC60		
RAM100	8006			RAM100	8067		
SR	0001	(C = 1)		SR	0000		

Example 2: **ADDC** **RAM200, WREG** **; Add RAM200 and C bit to the WREG**
; (Word mode)

Before Instruction				After Instruction			
WREG	5600			WREG	8A01		
RAM200	3400			RAM200	3400		
SR	0001	(C = 1)		SR	000C	(N, OV = 1)	

ADD		Add Short Literal to Wn	
Syntax:	{label:}	ADD.l	lit5, Wn
Operands:	lit5 ∈ [0 ... 31]; Wn ∈ [W0 ... W15]		
Operation:	(Wn) + lit5 → Wn Note: The literal is zero-extended to the selected data size of the operation		
Status Affected:	C, N, OV, Z		
Encoding:	0111	010k	kkkk ssss
Description:	Add the zero-extended literal operand to the contents of the Working register Wn and place the result in the Working register Wn. If literal >31 and/or word or byte operation is required, assemble as ADDLW instruction. The 's' bits select the Working register. The 'k' bits specify the signed literal operand.		
I-Words:	0.5		
Cycles:	1		

Example 1:	ADD.B	#0xFF, W7	; Add -1 to W7 (Byte mode)
	Before Instruction		After Instruction
	W7	12C0	W7 12BF
	SR	0000	SR 0009 (N, C = 1)

Example 2:	ADD	#0xFF, W1	; Add 255 to W1 (Word mode)
	Before Instruction		After Instruction
	W1	12C0	W1 13BF
	SR	0000	SR 0000

ADD		Add Ws and Short Literal							
Syntax:	{label:}	ADD.b	Ws,	lit7,	Wd				
		ADD.bz	[Ws],		[Wd]				
		ADD.{w}	[Ws++],		[Wd++]				
		ADD.l	[Ws--],		[Wd--]				
			[++Ws],		[++Wd]				
			[--Ws],		[--Wd]				
Operands:		Ws ∈ [W0 ... W15]; lit7 ∈ [0 ... 127]; Wd ∈ [W0 ... W15]							
Operation:		(Ws) + lit7 → Wd							
		Note: The literal is zero-extended to the selected data size of the operation							
Status Affected:		C, N, OV, Z							
Encoding:		1110	000L	dddd	ssss	pppq	qqkk	kkkk	Bk10
Description:		Add the contents of the source register Ws and the zero-extended unsigned literal operand and place the result in the destination register Wd. The 'L' and 'B' bits select operation data width. The 'k' bits provide the literal operand. The 's' bits select the source register. The 'd' bits select the destination register. The 'p' bits select the source addressing mode. The 'q' bits select the destination addressing mode.							
I-Words:		1							
Cycles:		1							

```

Example 1:      ADD.B          W0, #0x1F, W7          ; Add W0 and 31 (Byte mode)
                                                         ; Store the result in W7
    
```

	Before Instruction		After Instruction		
W0	2290	W0	2290		
W7	12C0	W7	12AF		
SR	0000	SR	0008	(N = 1)	

```

Example 2:      ADD          W3, #0x6, [--W4]        ; Add W3 and 6 (Word mode)
                                                         ; Store the result in [--W4]
    
```

	Before Instruction		After Instruction	
W3	6006	W3	6006	
W4	1000	W4	0FFE	
Data 0FFE	DDEE	Data 0FFE	600C	
Data 1000	DDEE	Data 1000	DDEE	
SR	0000	SR	0000	

ADD	Add Literal to Wn						
Syntax:	{label:}	ADD.b	lit16,	Wn			
		ADD.bz					
		ADD{.w}					
		ADD.l					
Operands:	lit16 ∈ [0 ... 65535]; Wn ∈ [W0 ... W15]						
Operation:	(Wn) + lit16 → Wn						
	Note: The literal is zero-extended to the selected data size of the operation						
Status Affected:	C, N, OV, Z						
Encoding:	1100	000L	ssss	kkkk	kkkk	kkkk	kkkk BU10
Description:	Add the zero-extended literal operand to the contents of the Working register Wn and place the result in the Working register Wn. The 'L' and 'B' bits select operation data width. The 's' bits select the Working register. The 'k' bits specify the signed literal operand.						
I-Words:	1						
Cycles:	1						

ADD		Add f and Wn			
Syntax:	{label:}	ADD.b	f	Wn	{,WREG}
		ADD.bz			
		ADD{.w}			
		ADD.l			
Operands:		f ∈ [0 ... 64KB]; Wn ∈ [W0 ... W15]			
Operation:		(f) + (Wn) → destination designated by D			
Status Affected:		C, N, OV, Z			
Encoding:		1110	000L	ssss	ffff ffff ffff ffff BD01
Description:		<p>Add the contents of the Working register and the contents of the file register and place the result in the destination designated by D. If the optional Wn is specified, D = 0 and store result in Wn; otherwise, D = 1 and store result in the file register.</p> <p>The 'L' and 'B' bits select operation data width.</p> <p>The 'D' bit selects the destination.</p> <p>The 'f' bits select the address of the file register.</p> <p>The 's' bits select the Working register.</p>			
I-Words:		1			
Cycles:		1			

Example 1: ADD.B RAM100 ; Add WREG to RAM100 (Byte mode)

Before Instruction		After Instruction	
WREG	CC80	WREG	CC80
RAM100	FFC0	RAM100	FF40
SR	0000	SR	0005 (OV, C = 1)

Example 2: ADD RAM200, WREG ; Add RAM200 to WREG (Word mode)

Before Instruction		After Instruction	
WREG	CC80	WREG	CC40
RAM200	FFC0	RAM200	FFC0
SR	0000	SR	0001 (C = 1)

AND		AND Wb and Ws			
Syntax:	{label:}	AND.b	Wb,	Ws,	Wd
		AND.bz		[Ws],	[Wd]
		AND{.w}		[Ws++],	[Wd++]
		AND.l		[Ws--],	[Wd--]
				[++Ws],	[++Wd]
				[--Ws],	[--Wd]
				SR	SR
Operands:	Wb ∈ [W0 ... W14]; Ws ∈ [W0 ... W15]; Wd ∈ [W0 ... W15]				
Operation:	(Wb).AND.(Ws) → Wd				
Status Affected:	N, Z				
Encoding:	s110	100L	dddd	ssss	pppq qqww wwUU BU00
Description:	<p>Compute the AND of the contents of the source register Ws and the contents of the base register Wb and place the result in the destination register Wd. The 'S' bit selects instruction size. The 'L' and 'B' bits select operation data width. The 's' bits select the source register. The 'w' bits select the base register. The 'd' bits select the destination register. The 'p' bits select the source addressing mode. The 'q' bits select the destination addressing mode. See and for modifier addressing information.</p> <p>Notes:</p> <ol style="list-style-type: none"> When the SR is selected, SR data write will take priority over any SR update resulting from the AND operation. .bz data size/mode is disallowed when writing to the SR. 				
I-Words:	1 or 0.5				
Cycles:	1				

```

Example 1:      AND.B          W0, W1 [W2++]          ; AND W0 and W1, and
                                                         ; store to [W2] (Byte mode)
                                                         ; Post-increment W2
    
```

Before Instruction		After Instruction	
W0	AA55	W0	AA55
W1	2211	W1	2211
W2	1001	W2	1002
Data 1000	FFFF	Data 1000	11FF
SR	0000	SR	0000

```

Example 2:      AND          W0, [W1++], W2          ; AND W0 and [W1], and
                                                         ; store to W2 (Word mode)
                                                         ; Post-increment W1
    
```

Before Instruction		After Instruction	
W0	AA55	W0	AA55
W1	1000	W1	1002
W2	55AA	W2	2214
Data 1000	2634	Data 1000	2634
SR	0000	SR	0000

AND	AND Ws and 0's Extended Short Literal
Syntax:	{label:} AND.b Ws, lit7, Wd AND.bz [Ws], [Wd] AND{.w} [Ws++], [Wd++] AND.l [Ws--], [Wd--] [++Ws], [++Wd] [--Ws], [--Wd] SR SR
Operands:	Ws ∈ [W0 ... W15]; lit7 ∈ [0 ... 127]; Wd ∈ [W0 ... W15]
Operation:	(Ws).AND.lit7 ³ → Wd
Status Affected:	N, Z (see note 1)
Encoding:	1110 100L dddd ssss pppq qqkk kkkk Bk10
Description:	<p>Compute the AND of the contents of the source register Ws and the zero-extended literal operand and place the result in the destination register Wd.</p> <p>The 'L' and 'B' bits select operation data width.</p> <p>The 'k' bits provide the unsigned literal operand.</p> <p>The 's' bits select the source register.</p> <p>The 'd' bits select the destination register.</p> <p>The 'p' bits select the source addressing mode.</p> <p>The 'q' bits select the destination addressing mode.</p> <p>Notes:</p> <ol style="list-style-type: none"> 1. When the SR is selected, SR data write will take priority over any SR update resulting from the AND operation. 2. .bz data size/mode is disallowed when writing to the SR. 3. The literal is zero-extended to the selected data size of the operation.
I-Words:	1
Cycles:	1

AND1		AND Ws and 1's Extended Short Literal							
Syntax:	{label:}	AND1.b	Ws,	lit7,	Wd				
		AND1.bz	[Ws],		[Wd]				
		AND1{.w}	[Ws++],		[Wd++]				
		AND1.l	[Ws--],		[Wd--]				
			[++Ws],		[++Wd]				
			[--Ws],		[--Wd]				
			SR		SR				
Operands:		Ws ∈ [W0 ... W15]; lit7 ∈ [0 ... 127]; Wd ∈ [W0 ... W15]							
Operation:		(Ws).AND.lit7 ³ → Wd							
Status Affected:		N, Z (see note 1)							
Encoding:		1110	110L	dddd	ssss	pppq	qqkk	kkkk	Bk10
Description:		<p>Compute the AND of the contents of the source register Ws and the ones-extended literal operand and place the result in the destination register Wd. The 'L' and 'B' bits select operation data width. The 'k' bits provide the unsigned literal operand. The 's' bits select the source register. The 'd' bits select the destination register. The 'p' bits select the source addressing mode. The 'q' bits select the destination addressing mode.</p> <p>Notes:</p> <ol style="list-style-type: none"> When the SR is selected, SR data write will take priority over any SR update resulting from the AND operation. .bz data size/mode is disallowed when writing to the SR. The literal is ones-extended to the selected data size of the operation. 							
I-Words:		1							
Cycles:		1							

```

Example 1:      AND1.l W5, #0x1F, W7      AND W5 and 1's extended
                                                    0x1F, and
                                                    ; store to [W7] (long word
                                                    mode)
                                                    ; Post-increment W2
    
```

Before Instruction		After Instruction	
W5	7FFFFFFF	W5	7FFFFFFF
W7	12345678	W7	7FFFFFF9F
SR	0000	SR	0000

AND		AND Literal and Wn							
Syntax:	{label:}	AND.b	lit16,	Wn					
		AND.bz		SR					
		AND{.w}							
		AND.l							
Operands:		lit16 ∈ [0 ... 65536]; Wn ∈ [W0 ... W15]; Status Register (SR)							
Operation:		(Wn) .AND. lit16 ³ → Wn or (SR) .AND. lit16 → SR							
Status Affected:		N, Z (see note 1)							
Encoding:		1100	100L	ssss	kkkk	kkkk	kkkk	kkkk	BT10
Description:		<p>Compute the AND of the literal operand and the contents of the Working register Wn or SR and place the result in the Working register Wn or SR. The 'L' and 'B' bits select operation data width. The 's' bits select the Working register. The 'k' bits specify the unsigned literal operand. The 'T' bit selects between Ws (T = 0) and SR (T = 1) target registers.</p> <p>Notes:</p> <ol style="list-style-type: none"> 1. When the SR is selected, SR data write will take priority over any SR update resulting from the AND operation. 2. .bz data size/mode is disallowed when writing to the SR. 3. The literal is zero-extended to 32-bits for long word operations. 							
I-Words:		1							
Cycles:		1							

Example 1:	AND.B #0x83, W7		; AND 0x83 to W7 (Byte mode)
	Before Instruction		After Instruction
	W7 12C0		W7 1280
	SR 0000		SR 0008 (N = 1)

Example 2:	AND #0x333, W1		; AND 0x333 to W1 (Word mode)
	Before Instruction		After Instruction
	W1 12D0		W1 0210
	SR 0000		SR 0000

AND		And f and Wn	
Syntax:	{label:}	AND.b	f ,Wn {,WREG}
		AND.bz	
		AND{.w}	
		AND.I	
Operands:	f ∈ [0 ... 64KB]; Wn ∈ [W0 ... W14]		
Operation:	(f).AND.(Wn) → destination designated by D		
Status Affected:	N, Z		
Encoding:	1110	100L	ssss ffff ffff ffff ffff BD01
Description:	<p>Compute the AND of the contents of the Working register and the contents of the file register and place the result in the destination designated by D. If the optional Wn is specified, D=0 and store result in Wn; otherwise, D=1 and store result in the file register.</p> <p>The 'L' and 'B' bits select operation data width.</p> <p>The 'D' bit selects the destination.</p> <p>The 'f' bits select the address of the file register.</p> <p>The 's' bits select the Working register.</p>		
I-Words:	1		
Cycles:	1		

Example 1:	AND.B RAM100	; AND WREG to RAM100 (Byte mode)
-------------------	---------------------	---

Before Instruction		After Instruction	
WREG	CC80	WREG	CC80
RAM100	FFC0	RAM100	FF80
SR	0000	SR	0008 (N = 1)

Example 2:	AND RAM200, WREG	; AND RAM200 to WREG (Word mode)
-------------------	-------------------------	---

Before Instruction		After Instruction	
WREG	CC80	WREG	0080
RAM200	12C0	RAM200	12C0
SR	0000	SR	0000

ASR		Arithmetic Shift Right by 1		
Syntax:	{label:}	ASR.b	Ws,	Wd
		ASR.bz	[Ws],	[Wd]
		ASR{.w}	[Ws++],	[Wd++]
		ASR.l	[Ws--],	[Wd--]
			[++Ws],	[++Wd]
			[--Ws],	[--Wd]
Operands:		Ws ∈ [W0 ... W15]; Wd ∈ [W0 ... W15]		
Operation:		For long word operation: (Ws[31]) → Wd[31], (Ws[31:1]) → Wd[30:0], (Ws[0]) → C		
		For word operation: (Ws[15]) → Wd[15], (Ws[15:1]) → Wd[14:0], (Ws[0]) → C		
		For byte operation: (Ws[7]) → Wd[7], (Ws[7:1]) → Wd[6:0], (Ws[0]) → C		
Status Affected:		C, N,Z		
Encoding:		S010	100L	dddd ssss pppq qqUU UUUU B000
Description:		Arithmetic shift right the contents of the source register by one bit, placing the result in the destination register Wd. Destination register direct Extended Byte or Word mode will zero-extend the result to 32-bits, then write to Wd. The 'S' bit selects instruction size. The 'L' and 'B' bits select operation data width. The 's' bits select the source register. The 'w' bits select the base register. The 'd' bits select the destination register. The 'p' bits select the source addressing mode. The 'q' bits select the destination addressing mode.		
I-Words:		1 or 0.5		
Cycles:		1		

ASR		Arithmetic Shift Right by Short Literal							
Syntax:	{label:}	ASR{.w}	Ws,	lit5,	Wd				
		ASR.l	[Ws],		[Wd]				
			[Ws++],		[Wd++]				
			[Ws--],		[Wd--]				
			[++Ws],		[++Wd]				
Operands:		Ws ∈ [W0 ... W15]; lit5 ∈ [0...31]; Wd ∈ [W0 ... W15]							
Operation:		lit5[4:0] → Shift_Val For long word operation: Ws[31] → Right shift input (arithmetic shift) Ws[31:0], 32'b0 → Shift_In[63:0] Arithmetic shift right Shift_In[63:0] by Shift_Val → Shift_Out[63:0] Shift_Out[63:32] → Wd For word operation: Ws[15] → Right shift input (arithmetic shift) {16{Ws[15]}}, Ws[15:0], 32'b0 → Shift_In[63:0] Arithmetic shift right Shift_In[63:0] by Shift_Val → Shift_Out[63:0] Shift_Out[47:32] → Wd[15:0]							
Status Affected:		N,Z							
Encoding:		s010	000k	kkkk	dddd	pppq	qqss	ssUU	LU00
Description:		<p>Arithmetic shift right the contents of the source register Ws by lit5 bits (up to 31 positions), placing the result in the destination Wd.</p> <p>This instruction will generate the correct result for a word operation with any shift value in lit5. If lit5 > 15 and Ws[15] = 0, then Wd[15:0]=0x0000. If lit5 > 15 and Ws[15] = 1, then Wd[15:0]=0xFFFF.</p> <p>Register Direct Word mode will zero-extend the result to 32-bits, then write to Wd.</p> <p>The 'S' bit selects instruction size.</p> <p>The 'L' bit selects word or long word operation.</p> <p>The 's' bits select the source register.</p> <p>The 'd' bits select the destination register.</p> <p>The 'p' bits select the source addressing mode.</p> <p>The 'q' bits select the destination addressing mode.</p> <p>The 'k' bits provide the literal operand.</p> <p>I-Words: 1 or 0.5 Cycles: 1</p> <p>Note:</p> <ol style="list-style-type: none"> This instruction only operates in Word or Long Word mode. 							

Example 1: ASR W0, #0x4, W1 ; ASR W0 by 4 and store to W1

Before Instruction		After Instruction	
W0	060F	W0	060F
W1	1234	W1	0060
SR	0000	SR	0000

Example 2: ASR W0, #0x6, W1 ; ASR W0 by 6 and store to W1

Before Instruction		After Instruction	
W0	80FF	W0	80FF
W1	0060	W1	FE03
SR	0000	SR	0008 (N = 1)

Example 3: **ASR W0, #0xF, W1** **; ASR W0 by 15 and store to W1**

Before		After	
Instruction		Instruction	
W0	70FF	W0	70FF
W1	CC26	W1	0000
SR	0000	SR	0002 (Z = 1)

ASRM	Arithmetic Shift Right Multi-Precision by Short Literal			
Syntax:	{label:}	ASRM{.l} Ws,	lit5,	Wnd
		[Ws],		
		[Ws++],		
		[Ws--],		
		[++Ws],		
		[--Ws],		
Operands:		Ws ∈ [W0 ... W15]; lit5 ∈ [0...31]; Wnd ∈ [W1 ... W14]		
Operation:		lit5[4:0] → Shift_Val Ws[31] → Right shift input (arithmetic shift) Ws[31:0], 32'b0 → Shift_In[63:0] Arithmetic shift right Shift_In[63:0] by Shift_Val → Shift_Out[63:0] Shift_Out[63:32] → Wnd Shift_Out[31:0] Wnd-1 → Wnd-1		
Status Affected:		N,Z		
Encoding:		1110	000k	kkkk dddd pppU UUss ssUU 0011
Description:		Arithmetic shift right the contents of the source register Ws by lit5 bits (up to 31 positions), placing the result in the destination register Wnd. The register containing the next least significant data word will already contain an intermediate shift result. Bitwise OR this value with the data shifted out of Ws in order to create the final shift result, then update the corresponding destination register. The Z bit is "sticky" (can only be cleared). The 's' bits select the source register. The 'd' bits select the destination register. The 'p' bits select the source addressing mode. The 'k' bits provide the literal operand.		
I-Words:		1		
Cycles:		2		
		1. Note: This instruction only operates in Long Word mode.		

ASRM	Arithmetic Shift Right Multi-Precision by Wb			
Syntax:	{label:}	ASRM{.l} Ws,	Wb,	Wnd
		[Ws],		
		[Ws++],		
		[Ws--],		
		[++Ws],		
		[--Ws],		
Operands:		Ws ∈ [W0 ... W15]; Wb ∈ [W0 ...W15]; Wnd ∈ [W1 ... W14]		
Operation:		Wb[15:0] → Shift_Val Ws[31] → Right shift input (arithmetic shift) Ws[31:0], 32'b0 → Shift_In[63:0] Arithmetic shift right Shift_In[63:0] by Shift_Val → Shift_Out[63:0] Shift_Out[63:32] → Wnd Shift_Out[31:0] Wnd-1 → Wnd-1		
Status Affected:		N,Z		
Encoding:		1110	001U	ssss dddd pppU UUww wwUU 0011

Instruction Descriptions (A to BZ) (continued)

ASRM	Arithmetic Shift Right Multi-Precision by Wb
Description:	<p>Arithmetic shift right the contents of the source register Ws by Wb bits, placing the result in the destination register Wnd. The register containing the next least significant data word will already contain an intermediate shift result. Bitwise OR this value with the data shifted out of Ws in order to create the final shift result, then update the corresponding destination register or memory address.</p> <p>The arithmetic right shift may be by any amount between 0 and 32 bits. Should the shift value held in Wb[15:0] exceed 2'd32, the shift value will saturate to 2'd32 for consistency. Any data held in Wb[31:16] will have no effect.</p> <p>The Z bit is "sticky" (can only be cleared).</p> <p>The 'w' bits select the base (shift count) register.</p> <p>The 's' bits select the source register.</p> <p>The 'd' bits select the destination register.</p> <p>The 'p' bits select the source addressing mode.</p> <p>Note: This instruction only operates in Long Word mode.</p>
I-Words:	1
Cycles:	2

ASR		Arithmetic Shift Right by Wb							
Syntax:	{label:}	ASR.b	Ws,	Wb,	Wd				
		ASR.bz	[Ws],		[Wd]				
		ASR{.w}	[Ws++],		[Wd++]				
		ASR.l	[Ws--],		[Wd--]				
			[++Ws],		[++Wd]				
			[--Ws],		[--Wd]				
Operands:		Ws ∈ [W0 ... W15]; Wb ∈ [W0 ...W15]; Wd ∈ [W0 ... W15]							
Operation:		<p>Wb[15:0] → Shift_Val For long word operation: Ws[31] → Right shift input (arithmetic shift) Ws[31:0], 32'b0 → Shift_In[63:0] Arithmetic shift right Shift_In[63:0] by Shift_Val → Shift_Out[63:0] Shift_Out[63:32] → Wd For word operation: Ws[15] → Right shift input (arithmetic shift) {16{Ws[15]}}, Ws[15:0],32'b0 → Shift_In[63:0] Arithmetic shift right Shift_In[63:0] by Shift_Val → Shift_Out[63:0] Shift_Out[47:32] → Wd[15:0] For byte operation: Ws<7> → Right shift input (arithmetic shift) {24{Ws<7>}}, Ws[7:0],32'b0 → Shift_In[63:0] Arithmetic shift right Shift_In[63:0] by Shift_Val → Shift_Out[63:0] Shift_Out[39:32] → Wd[7:0]</p>							
Status Affected:		N,Z							
Encoding:		1010	100L	www	ddd	pppq	qqss	ssUU	B100
Description:		<p>Arithmetic shift right the contents of the source register by Wb bits, placing the result in the destination register Wd. This instruction will generate the correct result for any shift value in Wb[15:0]:</p> <ul style="list-style-type: none"> For a byte operation shift value > 7: If Ws[7] = 0 then Wd[7:0]=0x00 else Wd[7:0]=0xFF For a word operation shift value > 15: If Ws[15] = 0 then Wd[15:0]=0x0000 else Wd[15:0]=0xFFFF For a Long Word operation shift value > 31: If Ws[31] = 0 then Wd[31:0]=0x00000000 else Wd[31:0]=0xFFFFFFFF Any data held in Wb[31:16] will have no effect. <p>Destination register direct Extended Byte or Word mode will zero-extend the result to 32-bits, then write to Wd. The 'L' and 'B' bits select operation data width. The 's' bits select the source register. The 'w' bits select the base (shift count) register. The 'd' bits select the destination register. The 'p' bits select the source addressing mode. The 'q' bits select the destination addressing mode.</p>							
I-Words:		1							
Cycles:		1							

BRA C		Branch if Carry/Unsigned Greater Than or Equal						
Syntax:	{label;} BRA C, Label {label;} BRA GEU,							
Operands:	Label is resolved by the linker to a signed word offset							
Operation:	Condition = C If (condition) then { If slit20 = 1 then skip next (16-bit) instruction Else If (slit20 = 2 && next_op[31] = 1) then skip next (32-bit) instruction Else (PC+4) + 2*slit20 → PC } Else no branch							
Status Affected:	None							
Encoding:	1010	101U	nnnn	nnnn	nnnn	nnnn	nnnn	0010
Description:	<p>If the branch condition is met, then the instruction will either skip the next 16-bit or 32-bit instruction, or branch to any size of instruction with a forward or backward range of up to 1MB.</p> <p>If the 2's complement byte offset value '2*slit20' (the PC offset) equals two, the conditional branch will execute as a conditional skip of one 16-bit instruction. This instruction will be speculatively executed as not skipped until such time that the branch decision can be determined.</p> <p>If the 2's complement byte offset value '2*slit20' (the PC offset) equals four, and the instruction after the branch is a 32-bit opcode (see note), the conditional branch will execute as a conditional skip of that 32-bit instruction. This instruction will be speculatively executed as not skipped until such time that the branch decision can be determined.</p> <p>If requirements for a conditional skip are not met, the 2's complement byte offset value '2*slit20' is added to the PC to create a new PS word address. Since the PC will have incremented to fetch the next instruction, the new address will be (PC+4) + 2*slit20.</p> <p>Branch prediction is based on the direction of the branch. If the branch is backwards (negative), it will be predicted as taken. If the branch is forwards (positive), it will be predicted as not taken. The two instructions that follow the branch will then be speculatively executed in the predicted path until such time that the actual branch decision can be assessed. A correctly predicted branch will continue instruction execution in the same path unabated. An incorrectly predicted branch will abort the speculatively executed instructions and start execution from the correct path.</p> <p>The 'n' bits are a signed literal that specifies the number of PS words offset from (PC+4).</p> <p>Note: Should the byte offset equal fourF and instruction after the branch is a 16-bit opcode, a branch will occur (over the next two 16-bit ops) if the condition is met.</p>							
I-Words:	1							
Cycles:	1 (2 or 3)							
	Note: The taken branch target instruction fetch is not executed if an exception is pending, making effective instruction execution time one cycle.							

Example:1	Address	Label	Instruction	Comment
	0x804000	-	BRA C, _CHECK_FAIL	;Branch if (N&&OV) (!(N&&!OV), to0x804030(_CHECK_FAIL)
	0x804004	_PASS_CONDITION:	SL.I w5, w6	
	
	
	
	0x804030	_CHECK_FAIL:	MOV.I SR, W6	; _CHECK_FAIL SubRoutine
	...		CP w6, w7	
	

Instruction Descriptions (A to BZ) (continued)

Example:1	Address	Label	Instruction	Comment
		Before execution		After execution
		PC 0x804000		PC 0x804030
		w15 0x4500		w15 0x4500
		SR[7:0] 8'b0000001	(C = 1;)	SR[7:0] 8'b0000001 (C = 1;)

BCLR		Bit Clear in Ws						
Syntax:	{label:}	BCLR.b	Ws,	bit5				
		BCLR{.w}	[Ws],					
		BCLR.l	[Ws++],					
			[Ws--],					
			[++Ws],					
			[--Ws],					
			SR					
Operands:	Ws ∈ [W0 ... W15]; Byte: bit5 ∈ [0 ... 7]; Word: bit5 ∈ [0 ... 15]; Long word: bit5 ∈ [0 ... 31]							
Operation:	0 → Ws<bit5>							
Status Affected:	None (see Note 1)							
Encoding:	s100	000b	bbbb	ssss	pppU	UUUU	UUUU	LB00
Description:	Bit 'bit5' in register Ws is cleared. The 'S' bit selects instruction size. The 'L' and 'B' bits select operation data width. The 'b' bits define value or bit5 of the bit position to be cleared (bit5[4:0] for the 16-bit opcode). The 's' bits select the source/destination register. The 'p' bits select the source addressing mode.							
	Note:							
	1. When targeting the SR, a bit within the SR will be cleared as a result of the instruction operation.							
I-Words:	1 or 0.5							
Cycles:	1							

Example 1: BCLR.B W2, #0x2 ; Clear bit 3 in W2

Before Instruction	After Instruction
W2 F234	W2 F230
SR 0000	SR 0000

**Example 2: BCLR [W0++], #0x0 ; Clear bit 0 in [W0]
; Post-increment W0**

Before Instruction	After Instruction
W0 2300	W0 2302
Data 2300 5607	Data 2300 5606
SR 0000	SR 0000

BCLR		Bit Clear in f						
Syntax:	{label:}	BCLR.b	f,	bit3				
Operands:	bit3 ∈ [0 ... 7]; f ∈ [0 ... 1MB]							
Operation:	0 → f[bit3]							
Status Affected:	None							
Encoding:	1100	000b	ffff	ffff	ffff	ffff	ffff	bb01
Description:	Bit 'bit3' in file register f is cleared. The 'w' bits select value bit3 of the bit position to be cleared. The 'f' bits select the address of the file register.							
	Notes:							
	1. This instruction operates in Byte mode only. 2. The .b extension must be included with the opcode.							
I-Words:	1							
Cycles:	1							

Example 1:	BCLR.B 0x800, #0x7	; Clear bit 7 in 0x800
-------------------	---------------------------	-------------------------------

Before		After	
Instruction		Instruction	
Data 0800	66EF	Data 0800	666F
SR	0000	SR	0000

Example 2:	BCLR 0x400, #0x9	; Clear bit 9 in 0x400
-------------------	-------------------------	-------------------------------

Before		After	
Instruction		Instruction	
Data 0400	AA55	Data 0400	A855
SR	0000	SR	0000

BFEXT		Bit Field Extract from Ws into Wb					
Syntax:	{label:}	BFEXT{.w} bit5, BFEXT.l	wid6,	Ws, [Ws], [Ws++], [Ws--], [++Ws], [--Ws], SR	Wb		
Operands:		Word: bit5 ∈ [0 .. 15]; wid6 ∈ [0 .. 16] Long: bit5 ∈ [0 .. 31]; wid6 ∈ [0 .. 32] Ws ∈ [W0 ... W15]; Wb ∈ [W0 ... W14]					
Operation:		See text					
Status Affected:		None					
Encoding:		1111	100m	mmmm	ssss	pppc	ccww wwcc L111
Description:		<p>A bit field is extracted (copied) from (Ws), and written into Wb. The bit field data loaded into Wb starts at Wb[0], and all MSbs within Wb that are beyond the defined bit field width will be cleared. The bit location within Ws of the LSb of the bit field to be extracted is defined by operand bit5. The width of the bit field is defined by operand wid6 and may be between zero and up to 16-bits (word operation) or 32-bits (long word operation).</p> <p>Word mode will zero-extend the result to 32-bits prior to the write to Wb.</p> <p>The 'L' bit selects word or long word operation.</p> <p>The 'w' bits select the bit field destination register.</p> <p>The 's' bits select the data source register.</p> <p>The 'p' bits select the source addressing mode.</p> <p>The 'cccc' bits define the bit field LSb position within the target word.</p> <p>The 'mmmm' bits define the bit field MSb position within the target word.</p> <p>Note:</p> <ol style="list-style-type: none"> Literal wid6 = 0 is a legal value for both long and word sized operations. 					
I-Words:		1					
Cycles:		1					

BFEXT		Bit Field Extract from f into Wb							
Syntax:	{label:}	BFEXT{.w} bit5,	wid6,	f,	Wb				
		BFEXT.l							
Operands:		bit5 ∈ [0 .. 31]; wid6 ∈ [0 .. 32] Wb ∈ [W0 ... W14]; f ∈ [0 ... 1MB]							
Operation:		See text							
Status Affected:		None							
Encoding:									
1st word		1100	110U	ffff	ffff	ffff	ffff	ffff	1001
2nd word		1100	110L	UUUm	mmm	UUUc	ccww	wwcc	1101
Description:		<p>A bit field is extracted (copied) from the file register address and written into Wb. The bit field data loaded into Wb starts at Wb[0], and all MSBs within Wb that are beyond the defined bit field width will be cleared.</p> <p>The bit location within the file register of the LSb of the bit field to be extracted is defined by operand bit5. The width of the bit field is defined by operand wid6 and may be between 0 and up to 16-bits (word operation) or 32-bits (long word operation).</p> <p>Word mode will zero-extended the result to 32-bits and then write to Wb.</p> <p>The 'L' bit selects word or long word operation.</p> <p>The 'w' bits select the bit field destination register.</p> <p>The 'f' bits select the address of the source file register.</p> <p>The 'cccc' bits define the bit field LSb position within the target word.</p> <p>The 'mmmm' bits define the bit field MSb position within the target word.</p> <p>Notes:</p> <ol style="list-style-type: none"> Literal wid6 = 0 is a legal value for both long and word sized operations. Accessible file address space is 1MB. LSb of 'f' bits is 1'b0 for word operation. LS 2-bits of 'f' bits is 2'b00 for long word operation. 							
I-Words:		2							
Cycles:		2							

BFINS		Bit Field Insert from Wb into Ws						
Syntax:	{label:}	BFINS{.w} bit5,	wid6,	Wb,	Ws			
		BFINS.l			[Ws]			
					[Ws++]			
					[Ws--]			
					[++Ws]			
					[--Ws]			
					SR			
Operands:		Word: bit5 ∈ [0 .. 15]; wid6 ∈ [0 .. 16] Long: bit5 ∈ [0 .. 31]; wid6 ∈ [0 .. 32] Wb ∈ [W0 ... W14]; Ws ∈ [W0 ... W15]						
Operation:		See text						
Status Affected:		None						
Encoding:		1111	100m	mmmm	ssss	pppC	ccww	wwcc L011
Description:		<p>A bit field is read from (Wb) and inserted (copied) into Ws. The bit field data sourced from Wb starts at Wb[0]. All MSBs within Wb that are beyond the defined bit field width are ignored and may be set to any value.</p> <p>The inserted bit field will overwrite the bits already in Ws or SR (i.e., the instruction does not shift any existing bits to accommodate the new bit field).</p> <p>The bit location within Ws of the LSb of the bit field to be inserted is defined by operand bit5. The width of the bit field is defined by operand wid6 and may be between zero and up to 16-bits (word operation) or 32-bits (long word operation).</p> <p>Word mode will zero-extend a Ws register direct result write to 32-bits.</p> <p>The 'L' bit selects word or long word operation.</p> <p>The 'w' bits select the bit field source register.</p> <p>The 's' bits select the data source/destination register.</p> <p>The 'p' bits select the source addressing mode.</p> <p>The 'cccc' bits define the bit field LSb position within the target word.</p> <p>The 'mmmm' bits define the bit field MSb position within the target word.</p> <p>Note:</p> <ol style="list-style-type: none"> Literal wid6 = 0 is a legal value for both long and word sized operations. 						
I-Words:		1						
Cycles:		1						

BFINS	Bit Field Insert from Wb into f							
Syntax:	{label:}	BFINS{.w}	bit5,	wid6,	Wb,	f		
		BFINS.I						
Operands:	Word: bit5 ∈ [0 .. 15]; wid6 ∈ [0 .. 16] Long: bit5 ∈ [0 .. 31]; wid6 ∈ [0 .. 32] Wb ∈ [W0 ... W14]; f ∈ [0 ... 1MB]							
Operation:	See text							
Status Affected:	None							
Encoding:								
1st word	1100	110U	ffff	ffff	ffff	ffff	ffff	0001
2nd word	1100	110L	UUUm	mmmm	UUUc	ccww	wwcc	0101
Description:	<p>A bit field is read from (Wb) and inserted (copied) into the file register address. The bit field data sourced from Wb starts at Wb[0]. All MSBs within Wb that are beyond the defined bit field width are ignored and may be set to any value.</p> <p>The inserted bit field will overwrite the bits already in the file register (i.e., the instruction does not shift any existing bits to accommodate the new bit field).</p> <p>The bit location within the file register of the LSb of the bit field to be inserted is defined by operand bit5. The width of the bit field is defined by operand wid6 and may be between zero and up to 16-bits (word operation) or 32-bits (long word operation).</p> <p>The 'w' bits select the bit field source register.</p> <p>The 'f' bits select the source/destination file register.</p> <p>The 'cccc' bits define the bit field LSb position within the target word.</p> <p>The 'mmmm' bits define the bit field MSb position within the target word.</p> <p>Notes:</p> <ol style="list-style-type: none"> Literal wid6 = 0 is a legal value for both long and word sized operations. Accessible file address space is 1MB. LSb of 'f' bits is 1'b0 for word operation. LS 2-bits of 'f' bits is 2'b00 for long word operation. 							
I-Words:	2							
Cycles:	2							

BFINS		Bit Field Insert Literal into Ws						
Syntax:	{label:}	BFINS{.w} bit5,	wid6,	lit16,	Ws			
		BFINS.l			[Ws]			
					[Ws++]			
					[Ws--]			
					[++Ws]			
					[--Ws]			
Operands:		bit5 ∈ [0 .. 31]; wid6 ∈ [0 .. 32] lit16 ∈ [0 .. 65536]; Ws ∈ [W0 ... W15]						
Operation:		See text						
Status Affected:		None						
Encoding:								
1st word		1100	101U	UUUU	kkkk	kkkk	kkkk	kkkk U001
2nd word		1100	101m	mmmm	ssss	pppc	ccUU	UUcc L101
Description:		<p>A bit field literal value is inserted (copied) into Ws. The bit field data sourced from the literal starts at the LSb of the literal. All MSBs within the literal value that are beyond the defined bit field width are ignored and may be set to any value.</p> <p>The inserted bit field will overwrite the bits already in Ws (i.e., the instruction does not shift any existing bits to accommodate the new bit field).</p> <p>The bit location within Ws of the LSb of the bit field to be inserted is defined by operand bit5. The width of the bit field is defined by operand wid6 and may be between zero and up to 16-bits (word operation) or 32-bits (long word operation).</p> <p>Word mode will zero-extend a Ws register direct result write to 32-bits.</p> <p>The 'L' bit selects word or long word operation.</p> <p>The 'k' bits contain the bit field source value.</p> <p>The 's' bits select the source/destination register.</p> <p>The 'p' bits select the source addressing mode.</p> <p>The 'cccc' bits define the bit field LSb position within the target word.</p> <p>The 'mmmm' bits define the bit field MSb position within the target word.</p> <p>Note:</p> <ol style="list-style-type: none"> Literal wid6 = 0 is a legal value for both long and word sized operations. 						
I-Words:		2						
Cycles:		2						

BRA GE		Branch if Signed Greater Than or Equal						
Syntax:	{label:}	BRA	GE,	Label				
Operands:	Label is resolved by the linker to a signed word offset (slit20)							
Operation:	Condition = (N&&OV) (!(N&&!OV)) If (condition) then { If slit20 = 1 then skip next (16-bit) instruction Else if (slit20 = 2 && next_op[31] = 1) then skip next (32-bit) instruction Else (PC+4) + 2*slit20 → PC } Else no branch							
Status Affected:	None							
Encoding:	1010	100U	nnnn	nnnn	nnnn	nnnn	nnnn	0110
Description:	<p>If the branch condition is met, then the instruction will either skip the next 16-bit or 32-bit instruction, or it will branch to any size of instruction with a forward or backward range of 1MB. If the 2's complement byte offset value '2*slit20' (the PC offset) equals two, the conditional branch will execute as a conditional skip of one 16-bit instruction. This instruction will be speculatively executed as not skipped until such time that the branch decision can be determined.</p> <p>If the 2's complement byte offset value '2*slit20' (the PC offset) equals four and the instruction after the branch is a 32-bit opcode (see note), the conditional branch will execute as a conditional skip of that 32-bit instruction. This instruction will be speculatively executed as not skipped until such time that the branch decision can be determined.</p> <p>If requirements for a conditional skip are not met, the 2's complement byte offset value '2*slit20' is added to the PC to create a new PS word address. Since the PC will have incremented to fetch the next instruction, the new address will be (PC+4) + 2*slit20.</p> <p>Branch prediction is based on the direction of the branch. If the branch is backwards (negative), it will be predicted as taken. If the branch is forwards (positive), it will be predicted as not taken. The two instructions that follow the branch will then be speculatively executed in the predicted path until such time that the actual branch decision can be assessed. A correctly predicted branch will continue instruction execution in the same path unabated. An incorrectly predicted branch will abort the speculatively executed instructions and start execution from the correct path.</p> <p>The 'n' bits are a signed literal that specifies the number of PS words offset from (PC+4).</p> <p>Note: Should the byte offset equal four and instruction after the branch is a 16-bit opcode, a branch will occur (over the next two 16-bit ops) if the condition is met.</p>							
I-Words:	1							
Cycles:	1 (2 or 3)							
	The taken branch target instruction fetch is not executed if an exception is pending, making effective instruction execution time one cycle.							

Example:1	Address	Label	Instruction	Comment
	0x804000	-	BRA GE, _CHECK_FAIL	;Branch if (N&&OV) (!(N&&!OV)), to0x804030(_CHECK_FAIL)
	0x804004	_PASS_CONDITION:	SL.I w5, w6	
	
	
	
	0x804030	_CHECK_FAIL:	MOV.I SR, W6	; _CHECK_FAIL SubRoutine
	...		CP w6, w7	
	
	Before execution			After execution

Instruction Descriptions (A to BZ) (continued)

Example:1	Address	Label	Instruction	Comment
	PC	0x804000		PC 0x804030
	w15	0x4500		w15 0x4500
	SR[7:0]	8'b0001100	(N = 1; OV = 1)	SR[7:0] 8'b0001100 (N = 1; OV = 1)

BRA GT		Branch if Signed Greater Than						
Syntax:	{label;} BRA GT, Label							
Operands:	Label is resolved by the linker to a signed word offset (slit20)							
Operation:	Condition = (!Z&&N&&OV) (!Z&&!N&&!OV); If (condition) then { If slit20 = 1 then skip next (16-bit) instruction Else if (slit20 = 2 && next_op[31] = 1) then skip next (32-bit) instruction Else (PC+4) + 2*slit20 → PC } Else no branch							
Status Affected:	None							
Encoding:	1010 100U nnnn nnnn nnnn nnnn nnnn 0010							
Description:	<p>If the branch condition is met, then the instruction will either skip the next 16-bit or 32-bit instruction, or it will branch to any size of instruction with a forward or backward range of 1MB. If the 2's complement byte offset value '2*slit20' (the PC offset) equals two, the conditional branch will execute as a conditional skip of one 16-bit instruction. This instruction will be speculatively executed as not skipped until such time that the branch decision can be determined.</p> <p>If the 2's complement byte offset value '2*slit20' (the PC offset) equals four and the instruction after the branch is a 32-bit opcode (see note), the conditional branch will execute as a conditional skip of that 32-bit instruction. This instruction will be speculatively executed as not skipped until such time that the branch decision can be determined.</p> <p>If requirements for a conditional skip are not met, the 2's complement byte offset value '2*slit20' is added to the PC to create a new PS word address. Since the PC will have incremented to fetch the next instruction, the new address will be (PC+4) + 2*slit20.</p> <p>Branch prediction is based on the direction of the branch. If the branch is backwards (negative), it will be predicted as taken. If the branch is forwards (positive), it will be predicted as not taken. The two instructions that follow the branch will then be speculatively executed in the predicted path until such time that the actual branch decision can be assessed. A correctly predicted branch will continue instruction execution in the same path unabated. An incorrectly predicted branch will abort the speculatively executed instructions and start execution from the correct path.</p> <p>The 'n' bits are a signed literal that specifies the number of PS words offset from (PC+4).</p> <p>Note: Should the byte offset equal four and instruction after the branch is a 16-bit opcode, a branch will occur (over the next two 16-bit ops) if the condition is met.</p>							
I-Words:	1							
Cycles:	1 (2 or 3) Note: The taken branch target instruction fetch is not executed if an exception is pending, making effective instruction execution time one cycle.							

Example:1	Address	Label	Instruction	Comment
	0x804000	-	BRA GT, _CHECK_FAIL	;Branch if (!Z&&N&&OV) (!Z&&!N&&!OV), to0x804030(_CHECK_FAIL)
	0x804004	_PASS_CONDITION:	SL.l w5, w6	
	
	
	
	0x804030	_CHECK_FAIL:	MOV.l SR, W6	; _CHECK_FAIL SubRoutine
	...		CP w6, w7	
	
	Before execution		After execution	
	PC	0x804000	PC	0x804030
	w15	0x4500	w15	0x4500

Instruction Descriptions (A to BZ) (continued)

Example:1	Address	Label	Instruction	Comment
	SR[7:0]	8'b0001100	(Z = 0;OV = 1; SR[7:0] N=1)	8'b0001100 (Z = 0;OV = 1; N=1)

BRA GTU		Branch if Unsigned Greater Than						
Syntax:	{label:}	BRA	GTU,	Label				
Operands:	Label is resolved by the linker to a signed word offset (slit20)							
Operation:	Condition = (C&&!Z); If (condition) then { If slit20 = 1 then skip next (16-bit) instruction Else if (slit20 = 2 && next_op[31] = 1) then skip next (32-bit) instruction Else (PC+4) + 2*slit20 → PC } Else no branch							
Status Affected:	None							
Encoding:	1010	111U	nnnn	nnnn	nnnn	nnnn	nnnn	0110
Description:	<p>If the branch condition is met, then the instruction will either skip the next 16-bit or 32-bit instruction, or it will branch to any size of instruction with a forward or backward range of 1MB. Likewise, the literal is zero-extended to 32-bits for long-word instructions.</p> <p>If the 2's complement byte offset value '2*slit20' (the PC offset) equals two, the conditional branch will execute as a conditional skip of one 16-bit instruction. This instruction will be speculatively executed as not skipped until such time that the branch decision can be determined.</p> <p>If the 2's complement byte offset value '2*slit20' (the PC offset) equals four, and the instruction after the branch is a 32-bit opcode (see note), the conditional branch will execute as a conditional skip of that 32-bit instruction. This instruction will be speculatively executed as not skipped until such time that the branch decision can be determined.</p> <p>If requirements for a conditional skip are not met, the 2's complement byte offset value '2*slit20' is added to the PC, to create a new PS word address. Since the PC will have incremented to fetch the next instruction, the new address will be (PC+4) + 2*slit20.</p> <p>Branch prediction is based on the direction of the branch. If the branch is backwards (negative), it will be predicted as taken. If the branch is forwards (positive), it will be predicted as not taken. The two instructions that follow the branch will then be speculatively executed in the predicted path until such time that the actual branch decision can be assessed. A correctly predicted branch will continue instruction execution in the same path unabated. An incorrectly predicted branch will abort the speculatively executed instructions and start execution from the correct path.</p> <p>The 'n' bits are a signed literal that specifies the number of PS words offset from (PC+4).</p> <p>Note: Should the byte offset equal four and instruction after the branch is a 16-bit opcode, a branch will occur (over the next two 16-bit ops) if the condition is met.</p>							
I-Words:	1							
Cycles:	1 (2 or 3)							
	Note: The taken branch target instruction fetch is not executed if an exception is pending, making effective instruction execution time one cycle.							

Example:1	Address	Label	Instruction	Comment
	0x804000	-	BRA GTU, _CHECK_FAIL	; Branch if (C&&! Z), to0x804030(CH ECK_FAIL)
	0x804004	_PASS_CONDITI ON:	SL.I w5, w6	
	
	
	
	0x804030	_CHECK_FAIL:	MOV.I SR, W6	; _CHECK_FAIL SubRoutine
	...		CP w6, w7	
	
	Before execution			After execution

Instruction Descriptions (A to BZ) (continued)

Example:1	Address	Label	Instruction	Comment
	PC	0x804000		PC 0x804030
	w15	0x4500		w15 0x4500
	SR[7:0]	8'b0000001	(C = 1, Z = 0)	SR[7:0] 8'b0000001 (C = 1, Z = 0)

BRA LE		Branch if Signed Less Than or Equal						
Syntax:	{label:}	BRA	LE,	Label				
Operands:	Label is resolved by the linker to a signed word offset (slit20)							
Operation:	Condition = Z (N&&!OV) (!N&&OV); If (condition) then { If slit20 = 1 then skip next (16-bit) instruction Else if (slit20 = 2 && next_op[31] = 1) then skip next (32-bit) instruction Else (PC+4) + 2*slit20 → PC } Else no branch							
Status Affected:	None							
Encoding:	1010	100U	nnnn	nnnn	nnnn	nnnn	nnnn	1110
Description:	If the branch condition is met, then the instruction will either skip the next 16-bit or 32-bit instruction, or it will branch to any size of instruction with a forward or backward range of 1MB. If the 2's complement byte offset value '2*slit20' (the PC offset) equals two, the conditional branch will execute as a conditional skip of one 16-bit instruction. This instruction will be speculatively executed as not skipped until such time that the branch decision can be determined. If the 2's complement byte offset value '2*slit20' (the PC offset) equals four, and the instruction after the branch is a 32-bit opcode (see note), the conditional branch will execute as a conditional skip of that 32-bit instruction. This instruction will be speculatively executed as not skipped until such time that the branch decision can be determined. If requirements for a conditional skip are not met, the 2's complement byte offset value '2*slit20' is added to the PC to create a new PS word address. Since the PC will have incremented to fetch the next instruction, the new address will be (PC+4) + 2*slit20. Branch prediction is based on the direction of the branch. If the branch is backwards (negative), it will be predicted as taken. If the branch is forwards (positive), it will be predicted as not taken. The two instructions that follow the branch will then be speculatively executed in the predicted path until such time that the actual branch decision can be assessed. A correctly predicted branch will continue instruction execution in the same path unabated. An incorrectly predicted branch will abort the speculatively executed instructions and start execution from the correct path. The 'n' bits are a signed literal that specifies the number of PS words offset from (PC+4). Note: Should the byte offset equal four and instruction after the branch is a 16-bit opcode, a branch will occur (over the next two 16-bit ops) if the condition is met.							
I-Words:	1							
Cycles:	1 (2 or 3)							
	Note: The taken branch target instruction fetch is not executed if an exception is pending, making effective instruction execution time one cycle.							

Example:1	Address	Label	Instruction	Comment	
	0x804000	-	BRA LE, _CHECK_FAIL	;Branch if Z (N&&!OV) (!N&&OV), to0x804030(_CHECK_FAIL)	
	0x804004	_PASS_CONDITION:	SL.l w5, w6		
		
		
		
	0x804030	_CHECK_FAIL:	MOV.l SR, W6	; _CHECK_FAIL SubRoutine	
	...		CP w6, w7		
		
		Before execution		After execution	
	PC	0x804000		PC	0x804030
	w15	0x4500		w15	0x4500
	SR[7:0]	8'b0000010	(Z = 1)	SR[7:0]	8'b0000010 (Z = 1)

BRA LEU		Branch if Unsigned Less Than or Equal						
Syntax:	{label:}	BRA	LEU,	Label				
Operands:	Label is resolved by the linker to a signed word offset (slit20)							
Operation:	Condition = !C Z; If (condition) then { If slit20 = 1 then skip next (16-bit) instruction Else if (slit20 = 2 && next_op[31] = 1) then skip next (32-bit) instruction Else (PC+4) + 2*slit20 → PC } Else no branch							
Status Affected:	None							
Encoding:	1010	111U	nnnn	nnnn	nnnn	nnnn	nnnn	0010
Description:	<p>If the branch condition is met, then the instruction will either skip the next 16-bit or 32-bit instruction, or it will branch to any size of instruction with a forward or backward range of 1MB. Likewise, the literal is zero-extended to 32-bits for long-word instructions.</p> <p>If the 2's complement byte offset value '2*slit20' (the PC offset) equals two, the conditional branch will execute as a conditional skip of one 16-bit instruction. This instruction will be speculatively executed as not skipped until such time that the branch decision can be determined.</p> <p>If the 2's complement byte offset value '2*slit20' (the PC offset) equals four, and the instruction after the branch is a 32-bit opcode (see note), the conditional branch will execute as a conditional skip of that 32-bit instruction. This instruction will be speculatively executed as not skipped until such time that the branch decision can be determined.</p> <p>If requirements for a conditional skip are not met, the 2's complement byte offset value '2*slit20' is added to the PC to create a new PS word address. Since the PC will have incremented to fetch the next instruction, the new address will be (PC+4) + 2*slit20.</p> <p>Branch prediction is based on the direction of the branch. If the branch is backwards (negative), it will be predicted as taken. If the branch is forwards (positive), it will be predicted as not taken. The two instructions that follow the branch will then be speculatively executed in the predicted path until such time that the actual branch decision can be assessed. A correctly predicted branch will continue instruction execution in the same path unabated. An incorrectly predicted branch will abort the speculatively executed instructions and start execution from the correct path.</p> <p>The 'n' bits are a signed literal that specifies the number of PS words offset from (PC+4).</p> <p>Note: Should the byte offset equal four and instruction after the branch is a 16-bit opcode, a branch will occur (over the next two 16-bit ops) if the condition is met.</p>							
I-Words:	1							
Cycles:	1 (2 or 3)							
	Note: The taken branch target instruction fetch is not executed if an exception is pending, making effective instruction execution time one cycle.							

Example:1	Address	Label	Instruction	Comment
	0x804000	-	BRA LT, _CHECK_FAIL	;Branch if !C Z, to0x804030(_CHECK_FAIL)
	0x804004	_PASS_CONDITI ON:	SL.I w5, w6	
	
	
	
	0x804030	_CHECK_FAIL:	MOV.I SR, W6	; _CHECK_FAIL SubRoutine
	...		CP w6, w7	
	
	Before execution		After execution	
	PC	0x804000	PC	0x804030
	w15	0x4500	w15	0x4500

Instruction Descriptions (A to BZ) (continued)

Example:1	Address	Label	Instruction	Comment
	SR[7:0]	8'b0000000	(Z = 0;C = 0) SR[7:0]	8'b0000000 (Z = 0;C = 0)

BRA LT		Branch if Signed Less Than						
Syntax:	{label:}	BRA	LT,	Label				
Operands:	Label is resolved by the linker to a signed word offset (slit20)							
Operation:	Condition = (N&&!OV) (!N&&OV); If (condition) then { If slit20 = 1 then skip next (16-bit) instruction Else if (slit20 = 2 && next_op[31] = 1) then skip next (32-bit) instruction Else (PC+4) + 2*slit20 → PC } Else no branch							
Status Affected:	None							
Encoding:	1010	100U	nnnn	nnnn	nnnn	nnnn	nnnn	1010
Description:	<p>If the branch condition is met, then the instruction will either skip the next 16-bit or 32-bit instruction, or it will branch to any size of instruction with a forward or backward range of 1MB. If the 2's complement byte offset value '2*slit20' (the PC offset) equals two, the conditional branch will execute as a conditional skip of one 16-bit instruction. This instruction will be speculatively executed as not skipped until such time that the branch decision can be determined.</p> <p>If the 2's complement byte offset value '2*slit20' (the PC offset) equals four, and the instruction after the branch is a 32-bit opcode (see note), the conditional branch will execute as a conditional skip of that 32-bit instruction. This instruction will be speculatively executed as not skipped until such time that the branch decision can be determined.</p> <p>If requirements for a conditional skip are not met, the 2's complement byte offset value '2*slit20' is added to the PC to create a new PS word address. Since the PC will have incremented to fetch the next instruction, the new address will be (PC+4) + 2*slit20.</p> <p>Branch prediction is based on the direction of the branch. If the branch is backwards (negative), it will be predicted as taken. If the branch is forwards (positive), it will be predicted as not taken. The two instructions that follow the branch will then be speculatively executed in the predicted path until such time that the actual branch decision can be assessed. A correctly predicted branch will continue instruction execution in the same path unabated. An incorrectly predicted branch will abort the speculatively executed instructions and start execution from the correct path.</p> <p>The 'n' bits are a signed literal that specifies the number of PS words offset from (PC+4).</p> <p>Note: Should the byte offset equal four and instruction after the branch is a 16-bit opcode, a branch will occur (over the next two 16-bit ops) if the condition is met.</p>							
I-Words:	1							
Cycles:	1 (2 or 3)							
	Note: The taken branch target instruction fetch is not executed if an exception is pending, making effective instruction execution time one cycle.							

Example:1	Address	Label	Instruction	Comment
	0x804000	-	BRA LT, _CHECK_FAIL	;Branch if !C !Z, to 0x804030(_CHECK_FAIL)
	0x804004	_PASS_CONDITION:	SL.I w5, w6	
	
	
	
	0x804030	_CHECK_FAIL:	MOV.I SR, W6	; _CHECK_FAIL SubRoutine
	...		CP w6, w7	
	
	Before execution		After execution	
	PC	0x804000	PC	0x804030
	w15	0x4500	w15	0x4500

Instruction Descriptions (A to BZ) (continued)

Example:1	Address	Label	Instruction	Comment
	SR[7:0]	8'b0000000	(Z = 0;C = 0) SR[7:0]	8'b0000000 (Z = 0;C = 0)

BRA NC/LTU		Branch if Not Carry / Unsigned Less Than						
Syntax:	{label;} BRA NC, Label {label;} BRA LTU,							
Operands:	Label is resolved by the linker to a signed word offset (slit20)							
Operation:	Condition = !C If (condition) then { If slit20 = 1 then skip next (16-bit) instruction Else If (slit20 = 2 && next_op[31] = 1) then skip next (32-bit) instruction Else (PC+4) + 2*slit20 → PC } Else no branch							
Status Affected:	None							
Encoding:	1010	101U	nnnn	nnnn	nnnn	nnnn	nnnn	0110
Description:	<p>If the branch condition is met, then the instruction will either skip the next 16-bit or 32-bit instruction, or branch to any size of instruction with a forward or backward range of 1MB. If the 2's complement byte offset value '2*slit20' (the PC offset) equals two, the conditional branch will execute as a conditional skip of one 16-bit instruction. This instruction will be speculatively executed as not skipped until such time that the branch decision can be determined.</p> <p>If the 2's complement byte offset value '2*slit20' (the PC offset) equals four and the instruction after the branch is a 32-bit opcode (see note), the conditional branch will execute as a conditional skip of that 32-bit instruction. This instruction will be speculatively executed as not skipped until such time that the branch decision can be determined.</p> <p>If requirements for a conditional skip are not met, the 2's complement byte offset value '2*slit20' is added to the PC to create a new PS word address. Since the PC will have incremented to fetch the next instruction, the new address will be (PC+4) + 2*slit20.</p> <p>Branch prediction is based on the direction of the branch. If the branch is backwards (negative), it will be predicted as taken. If the branch is forwards (positive), it will be predicted as not taken. The two instructions that follow the branch will then be speculatively executed in the predicted path until such time that the actual branch decision can be assessed. A correctly predicted branch will continue instruction execution in the same path unabated. An incorrectly predicted branch will abort the speculatively executed instructions and start execution from the correct path.</p> <p>The 'n' bits are a signed literal that specifies the number of PS words offset from (PC+4).</p> <p>Note: Should the byte offset equal four and instruction after the branch is a 16-bit opcode, a branch will occur (over the next two 16-bit ops) if the condition is met.</p>							
I-Words:	1							
Cycles:	1 (2 or 3)							
	Note: The taken branch target instruction fetch is not executed if an exception is pending, making effective instruction execution time one cycle.							

Example:1	Address	Label	Instruction	Comment
	0x804000	-	BRA LTU, _CHECK_FAIL	; Branch if SR.C == 0, to0x804030_CHECK_FAIL)
	0x804004	_PASS_CONDITION:	SL.I w5, w6	
	
	
	
	0x804030	_CHECK_FAIL:	MOV.I SR, W6	; _CHECK_FAIL SubRoutine
	...		CP w6, w7	
	
		Before execution		After execution

Instruction Descriptions (A to BZ) (continued)

Example:1	Address	Label	Instruction	Comment
		PC 0x804000		PC 0x804030
		w15 0x4500		w15 0x4500
		SR[7:0] 8'b00000000	(C = 0)	SR[7:0] 8'b00000000 (C = 0)

BRA NN		Branch if Not Negative						
Syntax:	{label:}	BRA	NN,	Label				
Operands:	Label is resolved by the linker to a signed word offset (slit20)							
Operation:	Condition = !N If (condition) then { If slit20 = 1 then skip next (16-bit) instruction Else if (slit20 = 2 && next_op[31] = 1) then skip next (32-bit) instruction Else (PC+4) + 2*slit20 → PC } Else no branch							
Status Affected:	None							
Encoding:	1010	011U	nnnn	nnnn	nnnn	nnnn	nnnn	0110
Description:	<p>If the branch condition is met, then the instruction will either skip the next 16-bit or 32-bit instruction, or it will branch to any size of instruction with a forward or backward range of 1MB. If the 2's complement byte offset value '2*slit20' (the PC offset) equals two, the conditional branch will execute as a conditional skip of one 16-bit instruction. This instruction will be speculatively executed as not skipped until such time that the branch decision can be determined.</p> <p>If the 2's complement byte offset value '2*slit20' (the PC offset) equals four, and the instruction after the branch is a 32-bit opcode (see note), the conditional branch will execute as a conditional skip of that 32-bit instruction. This instruction will be speculatively executed as not skipped until such time that the branch decision can be determined.</p> <p>If requirements for a conditional skip are not met, the 2's complement byte offset value '2*slit20' is added to the PC to create a new PS word address. Since the PC will have incremented to fetch the next instruction, the new address will be (PC+4) + 2*slit20.</p> <p>Branch prediction is based on the direction of the branch. If the branch is backwards (negative), it will be predicted as taken. If the branch is forwards (positive), it will be predicted as not taken. The two instructions that follow the branch will then be speculatively executed in the predicted path until such time that the actual branch decision can be assessed. A correctly predicted branch will continue instruction execution in the same path unabated. An incorrectly predicted branch will abort the speculatively executed instructions and start execution from the correct path.</p> <p>The 'n' bits are a signed literal that specifies the number of PS words offset from (PC+4).</p> <p>Note: Should the byte offset equal four and instruction after the branch is a 16-bit opcode, a branch will occur (over the next two 16-bit ops) if the condition is met.</p>							
I-Words:	1							
Cycles:	1 (2 or 3)							
	Note: The taken branch target instruction fetch is not executed if an exception is pending, making effective instruction execution time one cycle.							

Example:1	Address	Label	Instruction	Comment
	0x804000	-	BRA NN, _CHECK_FAIL	; Branch if SR.N == 0, to 0x804030(_CHECK_FAIL)
	0x804004	_PASS_CONDITION:	SL.I w5, w6	
	
	
	
	0x804030	_CHECK_FAIL:	MOV.I SR, W6	; _CHECK_FAIL SubRoutine
	...		CP w6, w7	
	
	Before execution		After execution	
	PC	0x804000	PC	0x804004 (No Branch)
	w15	0x4500	w15	0x4500

Instruction Descriptions (A to BZ) (continued)

Example:1	Address	Label	Instruction	Comment
	SR[7:0]	8'b00001000	(N = 1) SR[7:0]	8'b00001000 (N = 1)

Example:2	Address	Label	Instruction	Comment
	0x804000	-	BRA N, _CHECK_FAIL	; Branch if SR.N == 1, to 0x804030(_CHECK_FAIL)
	0x804004	_PASS_CONDITION:	SL.I w5, w6	
	
	
	
	0x804030	_CHECK_FAIL:	MOV.I SR, W6	; _CHECK_FAIL SubRoutine
	...		CP w6, w7	
	

Before execution	After execution
PC 0x804000	PC 0x804030
w15 0x4500	w15 0x4500
SR[7:0] 8'b00001000 (N = 1)	SR[7:0] 8'b00001000 (N = 1)

BRA NOV		Branch if Not Overflow						
Syntax:	{label;} BRA NOV, Label							
Operands:	Label is resolved by the linker to a signed word offset (slit20)							
Operation:	Condition = !OV If (condition) then { If slit20 = 1 then skip next (16-bit) instruction Else if (slit20 = 2 && next_op[31] = 1) then skip next (32-bit) instruction Else (PC+4) + 2*slit20 → PC } Else no branch							
Status Affected:	None							
Encoding:	1010 101U nnnn nnnn nnnn nnnn nnnn 1110							
Description:	<p>If the branch condition is met, then the instruction will either skip the next 16-bit or 32-bit instruction, or it will branch to any size of instruction with a forward or backward range of 1MB. If the 2's complement byte offset value '2*slit20' (the PC offset) equals two, the conditional branch will execute as a conditional skip of one 16-bit instruction. This instruction will be speculatively executed as not skipped until such time that the branch decision can be determined.</p> <p>If the 2's complement byte offset value '2*slit20' (the PC offset) equals four and the instruction after the branch is a 32-bit opcode (see note), the conditional branch will execute as a conditional skip of that 32-bit instruction. This instruction will be speculatively executed as not skipped until such time that the branch decision can be determined.</p> <p>If requirements for a conditional skip are not met, the 2's complement byte offset value '2*slit20' is added to the PC to create a new PS word address. Since the PC will have incremented to fetch the next instruction, the new address will be (PC+4) + 2*slit20.</p> <p>Branch prediction is based on the direction of the branch. If the branch is backwards (negative), it will be predicted as taken. If the branch is forwards (positive), it will be predicted as not taken. The two instructions that follow the branch will then be speculatively executed in the predicted path until such time that the actual branch decision can be assessed. A correctly predicted branch will continue instruction execution in the same path unabated. An incorrectly predicted branch will abort the speculatively executed instructions and start execution from the correct path.</p> <p>The 'n' bits are a signed literal that specifies the number of PS words offset from (PC+4).</p> <p>Note: Should the byte offset equal four and instruction after the branch is a 16-bit opcode, a branch will occur (over the next two 16-bit ops) if the condition is met.</p>							
I-Words:	1							
Cycles:	1 (2 or 3) Note: The taken branch target instruction fetch is not executed if an exception is pending, making effective instruction execution time one cycle.							

Example:1	Address	Label	Instruction	Comment
	0x804000	-	BRA NOV, _CHECK_FAIL	; Branch if SR.OV == 0, to 0x804030(_CHECK_FAIL)
	0x804004	_PASS_CONDITION:	SL.I w5, w6	
	
	
	
	0x804030	_CHECK_FAIL:	MOV.I SR, W6	; _CHECK_FAIL SubRoutine
	...		CP w6, w7	
	
		Before execution		After execution
		PC 0x804000		PC 0x804004 (No Branch)
		w15 0x4500		w15 0x4500

Instruction Descriptions (A to BZ) (continued)

Example:1	Address	Label	Instruction	Comment
	SR[7:0]	8'b00000100	(OV = 1)	SR[7:0] 8'b00000100 (OV = 1)

BRA NZ		Branch if Not Zero						
Syntax:	{label;} BRA NZ, Label							
Operands:	Label is resolved by the linker to a signed word offset (slit20)							
Operation:	Condition = !Z If (condition) then { If slit20 = 1 then skip next (16-bit) instruction Else if (slit20 = 2 && next_op[31] = 1) then skip next (32-bit) instruction Else (PC+4) + 2*slit20 → PC } Else no branch							
Status Affected:	None							
Encoding:	1010 011U nnnn nnnn nnnn nnnn nnnn 1110							
Description:	<p>If the branch condition is met, then the instruction will either skip the next 16-bit or 32-bit instruction, or it will branch to any size of instruction with a forward or backward range of 1MB. If the 2's complement byte offset value '2*slit20' (the PC offset) equals two, the conditional branch will execute as a conditional skip of one 16-bit instruction. This instruction will be speculatively executed as not skipped until such time that the branch decision can be determined.</p> <p>If the 2's complement byte offset value '2*slit20' (the PC offset) equals four, and the instruction after the branch is a 32-bit opcode (see note), the conditional branch will execute as a conditional skip of that 32-bit instruction. This instruction will be speculatively executed as not skipped until such time that the branch decision can be determined.</p> <p>If requirements for a conditional skip are not met, the 2's complement byte offset value '2*slit20' is added to the PC to create a new PS word address. Since the PC will have incremented to fetch the next instruction, the new address will be (PC+4) + 2*slit20.</p> <p>Branch prediction is based on the direction of the branch. If the branch is backwards (negative), it will be predicted as taken. If the branch is forwards (positive), it will be predicted as not taken. The two instructions that follow the branch will then be speculatively executed in the predicted path until such time that the actual branch decision can be assessed. A correctly predicted branch will continue instruction execution in the same path unabated. An incorrectly predicted branch will abort the speculatively executed instructions and start execution from the correct path.</p> <p>The 'n' bits are a signed literal that specifies the number of PS words offset from (PC+4).</p> <p>Note: Should the byte offset equal four and instruction after the branch is a 16-bit opcode, a branch will occur (over the next two 16-bit ops) if the condition is met.</p>							
I-Words:	1							
Cycles:	1 (2 or 3) Note: The taken branch target instruction fetch is not executed if an exception is pending, making effective instruction execution time one cycle.							

Example:1	Address	Label	Instruction	Comment
	0x804000	-	BRA NZ, _CHECK_FAIL	; Branch if SR.Z == 0, to 0x804030(_CHECK_FAIL)
	0x804004	_PASS_CONDITION:	SL.I w5, w6	
	
	
	
	0x804030	_CHECK_FAIL:	MOV.I SR, W6	; _CHECK_FAIL SubRoutine
	...		CP w6, w7	
	
	Before execution		After execution	
	PC	0x804000	PC	0x804030
	w15	0x4500	w15	0x4500

Instruction Descriptions (A to BZ) (continued)

Example:1	Address	Label	Instruction	Comment
	SR[15:8]	8'b00000000	(Z = 0)	SR[15:8] 8'b00000000 (Z = 0)

BRA OA		Branch if Overflow Accumulator A						
Syntax:	{label:}	BRA	OA,	Label				
Operands:	Label is resolved by the linker to a signed word offset (slit20)							
Operation:	Condition = OA If (condition) then { If slit20 = 1 then skip next (16-bit) instruction Else if (slit20 = 2 && next_op[31] = 1) then skip next (32-bit) instruction Else (PC+4) + 2*slit20 → PC } Else no branch							
Status Affected:	None							
Encoding:	1010	110U	nnnn	nnnn	nnnn	nnnn	nnnn	0010
Description:	<p>If the branch condition is met, then the instruction will either skip the next 16-bit or 32-bit instruction, or it will branch to any size of instruction with a forward or backward range of 1MB. If the 2's complement byte offset value '2*slit20' (the PC offset) equals two, the conditional branch will execute as a conditional skip of one 16-bit instruction. This instruction will be speculatively executed as not skipped until such time that the branch decision can be determined.</p> <p>If the 2's complement byte offset value '2*slit20' (the PC offset) equals four and the instruction after the branch is a 32-bit opcode (see note), the conditional branch will execute as a conditional skip of that 32-bit instruction. This instruction will be speculatively executed as not skipped until such time that the branch decision can be determined.</p> <p>If requirements for a conditional skip are not met, the 2's complement byte offset value '2*slit20' is added to the PC to create a new PS word address. Since the PC will have incremented to fetch the next instruction, the new address will be (PC+4) + 2*slit20.</p> <p>Branch prediction is based on the direction of the branch. If the branch is backwards (negative), it will be predicted as taken. If the branch is forwards (positive), it will be predicted as not taken. The two instructions that follow the branch will then be speculatively executed in the predicted path until such time that the actual branch decision can be assessed. A correctly predicted branch will continue instruction execution in the same path unabated. An incorrectly predicted branch will abort the speculatively executed instructions and start execution from the correct path.</p> <p>The 'n' bits are a signed literal that specifies the number of PS words offset from (PC+4).</p> <p>Note: Should the byte offset equal four and instruction after the branch is a 16-bit opcode, a branch will occur (over the next two 16-bit ops) if the condition is met.</p>							
I-Words:	1							
Cycles:	1 (2 or 3)							
	Note: The taken branch target instruction fetch is not executed if an exception is pending, making effective instruction execution time one cycle.							

Example:1	Address	Label	Instruction	Comment
	0x804000	-	BRA OA, _CHECK_FAIL	; Branch if SR.OA == 1, to 0x804030(_CHECK_FAIL)
	0x804004	_PASS_CONDITION:	SL.I w5, w6	
	
	
	
	0x804030	_CHECK_FAIL:	MOV.I SR, W6	; _CHECK_FAIL SubRoutine
	...		CP w6, w7	
	
	Before execution		After execution	
	PC	0x804000	PC	0x804030
	w15	0x4500	w15	0x4500

Instruction Descriptions (A to BZ) (continued)

Example:1	Address	Label	Instruction	Comment
	SR[15:8]	8'b10001000	(OA, OAB = 1)	SR[15:8] 8'b10001000 (OA, OAB = 1)

BRA OB		Branch if Overflow Accumulator B						
Syntax:	{label:}	BRA	OB,	Label				
Operands:	Label is resolved by the linker to a signed word offset (slit20)							
Operation:	Condition = OB If (condition) then { If slit20 = 1 then skip next (16-bit) instruction Else if (slit20 = 2 && next_op[31] = 1) then skip next (32-bit) instruction Else (PC+4) + 2*slit20 → PC } Else no branch							
Status Affected:	None							
Encoding:	1010	110U	nnnn	nnnn	nnnn	nnnn	nnnn	0110
Description:	<p>If the branch condition is met, then the instruction will either skip the next 16-bit or 32-bit instruction, or it will branch to any size of instruction with a forward or backward range of 1MB. If the 2's complement byte offset value '2*slit20' (the PC offset) equals two, the conditional branch will execute as a conditional skip of one 16-bit instruction. This instruction will be speculatively executed as not skipped until such time that the branch decision can be determined.</p> <p>If the 2's complement byte offset value '2*slit20' (the PC offset) equals four and the instruction after the branch is a 32-bit opcode (see note), the conditional branch will execute as a conditional skip of that 32-bit instruction. This instruction will be speculatively executed as not skipped until such time that the branch decision can be determined.</p> <p>If requirements for a conditional skip are not met, the 2's complement byte offset value '2*slit20' is added to the PC to create a new PS word address. Since the PC will have incremented to fetch the next instruction, the new address will be (PC+4) + 2*slit20.</p> <p>Branch prediction is based on the direction of the branch. If the branch is backwards (negative), it will be predicted as taken. If the branch is forwards (positive), it will be predicted as not taken. The two instructions that follow the branch will then be speculatively executed in the predicted path until such time that the actual branch decision can be assessed. A correctly predicted branch will continue instruction execution in the same path unabated. An incorrectly predicted branch will abort the speculatively executed instructions and start execution from the correct path.</p> <p>The 'n' bits are a signed literal that specifies the number of PS words offset from (PC+4).</p> <p>Note: Should the byte offset equal four and instruction after the branch is a 16-bit opcode, a branch will occur (over the next two 16-bit ops) if the condition is met.</p>							
I-Words:	1							
Cycles:	1 (2 or 3)							
	Note: The taken branch target instruction fetch is not executed if an exception is pending, making effective instruction execution time one cycle.							

Example:1	Address	Label	Instruction	Comment
	0x804000	-	BRA OB, _CHECK_FAIL	; Branch if SR.OA == 1, to 0x804030(_CHECK_FAIL)
	0x804004	_PASS_CONDITION:	SL.I w5, w6	
	
	
	
	0x804030	_CHECK_FAIL:	MOV.I SR, W6	; _CHECK_FAIL SubRoutine
	...		CP w6, w7	
	
	Before execution		After execution	
	PC	0x804000	PC	0x804004 (No Branch)
	w15	0x4500	w15	0x4500

Instruction Descriptions (A to BZ) (continued)

Example:1	Address	Label	Instruction	Comment
	SR[15:8]	8'b00000000	(OB, OAB = 0) SR[15:8]	8'b00000000 (OB, OAB = 0)

BOOTSWP		Swap Active and Inactive Flash Address Space	
Syntax:	{label;} BOOTSWP		Ws
Operands:	Ws ∈ [W0 ... W14]		
Operation:			IF (cfg_bootswap_disable = 0) IF Ws valid (see text) 1 * Z IF (sec_dual_boot_active = 1) NVMCON.P2ACTIV * NVMCON.P2ACTIV 1 * NVMCON.SOFTSWAP ELSE no panel swap ELSE 0 * Z (and no panel swap) ELSE execute as 2 cycle NOP (and no panel swap)
Status Affected:	Z (when BOOTSWP enabled)		
Encoding:	1111	101U	UUUU ssss UUUU UUUU UUU1 0011
Description:	<p>If the BOOTSWP instruction is enabled (cfg_bootswap_disable = 0), it will confirm that Ws contains a valid Boot Sequence (BTSEQ) value (see note 1) before signaling the NVM Controller to execute a panel swap.</p> <p>If Ws is valid and the device is operating in Dual Boot mode (sec_dual_boot_active = 1), the following will occur:</p> <ol style="list-style-type: none"> 1. Toggle the state of the NVMCON.P2ACTIV Status bit which will swap the Active and Inactive Flash address spaces within the PS address map. 2. Set NVMCON.SOFTSWAP and Z = 1, indicating a successful panel swap. If Ws is valid but the device is not operating in Dual Boot mode, the Z-bit will still be set to 1'b1, but no panel swap will occur. If Ws is invalid, BOOTSWP will set Z = 0 (irrespective of whether the device is operating in Dual Boot mode or not), and no panel swap will occur. If the BOOTSWP instruction is not enabled, it will execute as a two cycle NOP instruction (the Z-bit will be unaffected and no panel swap will occur). The 's' bits specify the source register Ws. <p>Note: It is required that the Inactive panel BTSEQ value be loaded into Ws prior to the execution of BOOTSWP.</p>		
I-Words:	1		
Cycles:	2 + additional cycle(s) for PS memory instruction fetch from target space if Flash address space swap is successful.		

BRA OV		Branch if Overflow						
Syntax:	{label:}	BRA	OV,	Label				
Operands:	Label is resolved by the linker to a signed word offset (slit20)							
Operation:	Condition = OV If (condition) then { If slit20 = 1 then skip next (16-bit) instruction Else if (slit20 = 2 && next_op[31] = 1) then skip next (32-bit) instruction Else (PC+4) + 2*slit20 → PC } Else no branch							
Status Affected:	None							
Encoding:	1010	101U	nnnn	nnnn	nnnn	nnnn	nnnn	1010
Description:	<p>If the branch condition is met, then the instruction will either skip the next 16-bit or 32-bit instruction, or it will branch to any size of instruction with a forward or backward range of 1MB. If the 2's complement byte offset value '2*slit20' (the PC offset) equals two, the conditional branch will execute as a conditional skip of one 16-bit instruction. This instruction will be speculatively executed as not skipped until such time that the branch decision can be determined.</p> <p>If the 2's complement byte offset value '2*slit20' (the PC offset) equals four and the instruction after the branch is a 32-bit opcode (see note), the conditional branch will execute as a conditional skip of that 32-bit instruction. This instruction will be speculatively executed as not skipped until such time that the branch decision can be determined.</p> <p>If requirements for a conditional skip are not met, the 2's complement byte offset value '2*slit20' is added to the PC to create a new PS word address. Since the PC will have incremented to fetch the next instruction, the new address will be (PC+4) + 2*slit20.</p> <p>Branch prediction is based on the direction of the branch. If the branch is backwards (negative), it will be predicted as taken. If the branch is forwards (positive), it will be predicted as not taken. The two instructions that follow the branch will then be speculatively executed in the predicted path until such time that the actual branch decision can be assessed. A correctly predicted branch will continue instruction execution in the same path unabated. An incorrectly predicted branch will abort the speculatively executed instructions and start execution from the correct path.</p> <p>The 'n' bits are a signed literal that specifies the number of PS words offset from (PC+4).</p> <p>Note: Should the byte offset equal four and instruction after the branch is a 16-bit opcode, a branch will occur (over the next two 16-bit ops) if the condition is met.</p>							
I-Words:	1							
Cycles:	1 (2 or 3)							
	Note: The taken branch target instruction fetch is not executed if an exception is pending, making effective instruction execution time one cycle.							

Example:1	Address	Label	Instruction	Comment
	0x804000	-	BRA OV, _CHECK_FAIL	; Branch if SR.OV == 1, to 0x804030(_CHECK_FAIL)
	0x804004	_PASS_CONDITION:	SL.I w5, w6	
	
	
	
	0x804030	_CHECK_FAIL:	MOV.I SR, W6	; _CHECK_FAIL SubRoutine
	...		CP w6, w7	
	
	Before execution		After execution	
	PC	0x804000	PC	0x804030
	w15	0x4500	w15	0x4500

Instruction Descriptions (A to BZ) (continued)

Example:1	Address	Label	Instruction	Comment
	SR[7:0]	8'b00000100	(OV = 1)	SR[7:0] 8'b00000100 (OV = 1)

BRA Branch Unconditionally

Syntax: {label;} BRA Label

Operands: Label is resolved by the linker to a signed word offset (slit20)

Operation: (PC+4) + 2*slit20 → PC

Status Affected: None

Encoding: 1010 111U nnnn nnnn nnnn nnnn nnnn 1010

Description: The program will branch unconditionally with a forward or backward range of 1MB.
 The 2's complement byte offset value '2*slit20' (the PC offset) is added to the PC. Since the PC will have incremented to fetch the next instruction, the new address will be (PC+4) + 2*slit20.
 The 'n' bits are a signed literal that specifies the number of PS words to branch from (PC+4).

I-Words: 1

Cycles: 1

Example:1	Address	Label	Instruction	Comment
	0x804000	-	BRA _CHECK_FAIL	; Branch to label _CEHCK_FAIL
	0x804004	_PASS_CONDITION:	SL.I w5, w6	
	
	
	
	0x804030	_CHECK_FAIL:	MOV.I SR, W6	; _CHECK_FAIL SubRoutine
	...		CP w6, w7	
	
		Before execution		After execution
	PC	0x804000	PC	0x804030
	w15	0x4500	w15	0x4500

Example:2	Address	Label	Instruction	Comment
	0x804000	-	BRA _CHECK_FAIL + 4	; Branch to label _CEHCK_FAIL
	0x804004	_PASS_CONDITION:	SL.I w5, w6	
	
	
	
	0x804030	_CHECK_FAIL:	MOV.I SR, W6	; _CHECK_FAIL SubRoutine
	...		CP w6, w7	
	
		Before execution		After execution
	PC	0x804000	PC	0x804034
	w15	0x4500	w15	0x4500

BRA		Computed Branch						
Syntax:	{label:}	BRA	Wns					
Operands:	Wns ∈ [W0 ... W14]							
Operation:	(PC + 4) + 2*Wns[19:0] → PC, NOP → Instruction Register.							
Status Affected:	None							
Encoding:	1101	011U	UUUU	ssss	UUUU	UUUU	UUUU	0010
Description:	<p>Computed branch with a forward or backward branch address range of 1MB.</p> <p>The signed value in Wns[19:0] represents the PS (16-bit) word offset from the current PC. This value is multiplied by two to create a byte address that is then added to the contents of the PC to form the target address. Therefore, Wn must contain a signed value that specifies the number of PS words to offset from (PC+4) for the branch.</p> <p>The 's' bits select the source register.</p> <p>Note: If Wns[31:19] is not all 0's or all 1's, an address error trap will be initiated.</p>							
I-Words:	1							
Cycles:	2							
	Note: The branch target instruction fetch is not executed if an exception is pending, making effective instruction execution time one cycle.							

Example:1	Address	Label	Instruction	Comment
	0x803FFC		MOV.I #0x16, W7	
	0x804000	-	BRA W7	; Branch to offset contained in W7 (0x804004 + 2*0x16)
	0x804004	_PASS_CONDITION:	SL.I w5, w6	
	
	
	
	0x804030	_CHECK_FAIL:	MOV.I SR, W6	; _CHECK_FAIL SubRoutine
	...		CP w6, w7	
	
	Before execution		After execution	
	PC	0x804000	PC	0x804030
	w15	0x4500	w15	0x4500

BREAK	Break
Syntax:	{label;} BREAK
Operands:	none
Operation:	Application (User) Mode: Execute as NOP Debugger Mode: Mission Mode: Stop user code execution. Debug Mode: Execute as NOP
Status Affected:	None
Encoding:	S111 001U UUUU 0010 UUUU UUUU UUUU UU00
Description:	<p>BREAK will only execute as such when the device is operating in Mission mode. If encountered in any other mode, it will be executed as an NOP.</p> <p>BREAK will stop user code execution and switch from Mission into Debug mode where it will execute the resident Debug Executive (DE). The User PC is not modified by this instruction. All exceptions (including traps) are blocked while executing BREAK and while in Debug mode.</p> <p>In order to avoid possible hazards between Debug and Mission mode code, BREAK will execute two FNOPs prior to starting Debug mode execution. The total instruction cycle count includes these FNOPs.</p> <p>The 'S' bit selects instruction size.</p> <p>Note: 16-bit encoding (bold).</p>
I-Words:	1 or 0.5
Cycles:	3

BRA SA		Branch if ACCA Saturation						
Syntax:	{label:}	BRA	SA,	Label				
Operands:	Label is resolved by the linker to a signed word offset (slit20)							
Operation:	Condition = SA If (condition) then { If slit20 = 1 then skip next (16-bit) instruction Else if (slit20 = 2 && next_op[31] = 1) then skip next (32-bit) instruction Else (PC+4) + 2*slit20 → PC } Else no branch							
Status Affected:	None							
Encoding:	1010	110U	nnnn	nnnn	nnnn	nnnn	nnnn	1010
Description:	<p>If the branch condition is met, then the instruction will either skip the next 16-bit or 32-bit instruction, or it will branch to any size of instruction with a forward or backward range of 1MB. If the 2's complement byte offset value '2*slit20' (the PC offset) equals two, the conditional branch will execute as a conditional skip of one 16-bit instruction. This instruction will be speculatively executed as not skipped until such time that the branch decision can be determined.</p> <p>If the 2's complement byte offset value '2*slit20' (the PC offset) equals four and the instruction after the branch is a 32-bit opcode (see note), the conditional branch will execute as a conditional skip of that 32-bit instruction. This instruction will be speculatively executed as not skipped until such time that the branch decision can be determined.</p> <p>If requirements for a conditional skip are not met, the 2's complement byte offset value '2*slit20' is added to the PC to create a new PS word address. Since the PC will have incremented to fetch the next instruction, the new address will be (PC+4) + 2*slit20.</p> <p>Branch prediction is based on the direction of the branch. If the branch is backwards (negative), it will be predicted as taken. If the branch is forwards (positive), it will be predicted as not taken. The two instructions that follow the branch will then be speculatively executed in the predicted path until such time that the actual branch decision can be assessed. A correctly predicted branch will continue instruction execution in the same path unabated. An incorrectly predicted branch will abort the speculatively executed instructions and start execution from the correct path.</p> <p>The 'n' bits are a signed literal that specifies the number of PS words offset from (PC+4).</p> <p>Note: Should the byte offset equal four and instruction after the branch is a 16-bit opcode, a branch will occur (over the next two 16-bit ops) if the condition is met.</p>							
I-Words:	1							
Cycles:	1 (2 or 3)							
	Note: The branch target instruction fetch is not executed if an exception is pending, making effective instruction execution time one cycle.							

Example:1	Address	Label	Instruction	Comment
	0x804000	-	BRA SA, _CHECK_FAIL	; Branch if SR.SB == 1, to 0x804030(_CHECK_FAIL)
	0x804004	_PASS_CONDITION:	SL.I w5, w6	
	
	
	
	0x804030	_CHECK_FAIL:	MOV.I SR, W6	; _CHECK_FAIL SubRoutine
	...		CP w6, w7	
	
		Before execution		After execution
	PC	0x804000	PC	0x804004 (No Branch)
	w15	0x4500	w15	0x4500

Instruction Descriptions (A to BZ) (continued)

Example:1	Address	Label	Instruction	Comment
	SR[15:8]	8'b00000000	(SA, SAB = 0) SR[15:8]	8'b00000000 (SA, SAB = 0)

BRA SB		Branch if ACCB Saturation						
Syntax:	{label:}	BRA	SB,	Label				
Operands:	Label is resolved by the linker to a signed word offset (slit20)							
Operation:	Condition = SB If (condition) then { If slit20 = 1 then skip next (16-bit) instruction Else if (slit20 = 2 && next_op[31] = 1) then skip next (32-bit) instruction Else (PC+4) + 2*slit20 → PC } Else no branch							
Status Affected:	None							
Encoding:	1010	110U	nnnn	nnnn	nnnn	nnnn	nnnn	1110
Description:	<p>If the branch condition is met, then the instruction will either skip the next 16-bit or 32-bit instruction, or it will branch to any size of instruction with a forward or backward range of 1MB. If the 2's complement byte offset value '2*slit20' (the PC offset) equals two, the conditional branch will execute as a conditional skip of one 16-bit instruction. This instruction will be speculatively executed as not skipped until such time that the branch decision can be determined.</p> <p>If the 2's complement byte offset value '2*slit20' (the PC offset) equals four and the instruction after the branch is a 32-bit opcode (see note), the conditional branch will execute as a conditional skip of that 32-bit instruction. This instruction will be speculatively executed as not skipped until such time that the branch decision can be determined.</p> <p>If requirements for a conditional skip are not met, the 2's complement byte offset value '2*slit20' is added to the PC to create a new PS word address. Since the PC will have incremented to fetch the next instruction, the new address will be (PC+4) + 2*slit20.</p> <p>Branch prediction is based on the direction of the branch. If the branch is backwards (negative), it will be predicted as taken. If the branch is forwards (positive), it will be predicted as not taken. The two instructions that follow the branch will then be speculatively executed in the predicted path until such time that the actual branch decision can be assessed. A correctly predicted branch will continue instruction execution in the same path unabated. An incorrectly predicted branch will abort the speculatively executed instructions and start execution from the correct path.</p> <p>The 'n' bits are a signed literal that specifies the number of PS words offset from (PC+4).</p> <p>Note: Should the byte offset equal four and instruction after the branch is a 16-bit opcode, a branch will occur (over the next two 16-bit ops) if the condition is met.</p>							
I-Words:	1							
Cycles:	1 (2 or 3)							
	Note: The branch target instruction fetch is not executed if an exception is pending, making effective instruction execution time one cycle.							

Example:1	Address	Label	Instruction	Comment
	0x804000	-	BRA SB, _CHECK_FAIL	; Branch if SR.SB == 1, to 0x804030(_CHECK_FAIL)
	0x804004	_PASS_CONDITION:	SL.I w5, w6	
	
	
	
	0x804030	_CHECK_FAIL:	MOV.I SR, W6	; _CHECK_FAIL SubRoutine
	...		CP w6, w7	
	
		Before execution		After execution
	PC	0x804000	PC	0x804030
	w15	0x4500	w15	0x4500

Instruction Descriptions (A to BZ) (continued)

Example:1	Address	Label	Instruction	Comment
	SR[15:8]	8'b00010100	(SB, SAB = 1) SR[15:8]	8'b00000010 (SB, SAB = 1)

BSET		Bit Set in Ws						
Syntax:	{label:}	BSET.b	Ws,	bit5				
		BSET{.w}	[Ws],					
		BSET.l	[Ws++],					
			[Ws--],					
			[++Ws],					
			[--Ws],					
			SR					
Operands:		Ws ∈ [W0 ... W15];						
		Byte: bit5 ∈ [0 ... 7];						
		Word: bit5 ∈ [0 ... 15];						
		Long word: bit5 ∈ [0 ... 31]						
Operation:		1 → Ws<bit5>						
Status Affected:		None (see note 2)						
Encoding:		S100	001b	bbbb	ssss	pppU	UUUU	UUUU LB00
Description:		Bit 'bit5' in register Ws is set. The 'S' bit selects instruction size. The 'L' and 'B' bits select operation data width. The 'b' bits define value or bit5 of the bit position to be cleared (bit5[4:0] for the 16-bit opcode). The 's' bits select the source/destination register. The 'p' bits select the source addressing mode. See for modifier addressing information.						
		Note:						
		1. When targeting the SR, a bit within the SR will be set as a result of the instruction operation.						
I-Words:		1 or 0.5						
Cycles:		1						

Example 1: BSET.B W3, #0x7 ; Set bit 7 in W3

Before Instruction		After Instruction	
W3	0026	W3	00A6
SR	0000	SR	0000

**Example 2: BSET [W4++], #0x0 ; Set bit 0 in [W4]
; Post-increment W4**

Before Instruction		After Instruction	
W4	6700	W4	6702
Data 6700	1734	Data 6700	1735
SR	0000	SR	0000

BSET		Bit Set f						
Syntax:	{label:}	BSET.b	f,	bit3				
Operands:	bit3 ∈ [0 ... 7]; f ∈ [0 ... 1MB]							
Operation:	1 → f<bit3>							
Status Affected:	None							
Encoding:	1100	001b	ffff	ffff	ffff	ffff	ffff	bb01
Description:	Bit 'bit3' in file register f is set. The 'w' bits select value bit3 of the bit position to be set. The 'f' bits select the address of the file register.							
	Notes:							
	1. This instruction operates in Byte mode only. 2. The .b extension must be included with the opcode. 3. Accessible file address space is 1MB.							
I-Words:	1							
Cycles:	1							

Example 1:	BSET.B 0x601, #0x3	; Set bit 3 in 0x601
	Before Instruction	After Instruction
	Data 0600 F234	Data 0600 FA34
	SR 0000	SR 0000

Example 2:	BSET 0x444, #0xF	; Set bit 15 in 0x444
	Before Instruction	After Instruction
	Data 0444 5604	Data 0444 D604
	SR 0000	SR 0000

BSW		Bit Write in Ws	
Syntax:	{label:}	BSW.bC Ws, Wb	
		BSW.bZ [Ws],	
		BSW.{w}C [++Ws],	
		BSW.{w}Z [--Ws],	
		BSW.IC [Ws++],	
		BSW.IZ [Ws--],	
Operands:		Wb ∈ [W0 ... W14]; Ws ∈ [W0 ... W15]	
Operation:		If ".Z" option, then Z → Ws<(Wb)> If ".C" option, then C → Ws<(Wb)>	
Status Affected:		None	
Encoding:		S100	101L www ssss pppU UUUU UUG BU00
Description:		<p>The bit number defined in Wb is written in Ws with the value of the C or Z bit. For byte, word and long word operations, the target bit number is defined by Wb[2:0], Wb[3:0] and Wb[4:0], respectively. Any bit within Wb, beyond those bits required to select the target bit, will be ignored and may be set to any value.</p> <p>The 'S' bit selects instruction size.</p> <p>The 'L' and 'B' bits select operation data width.</p> <p>The 'w' bits select the bit select register.</p> <p>The 'G' bit selects the Z or C flag bit as source (G = 0 selects Z flag).</p> <p>The 's' bits select the source register.</p> <p>The 'p' bits select the source addressing mode.</p>	
I-Words:		1 or 0.5	
Cycles:		1	

**Example 1: BSW.C W2, W3 ; Set bit W3 in W2 to the value
; of the C bit**

Before Instruction		After Instruction	
W2	F234	W2	7234
W3	111F	W3	111F
SR	0002 (Z = 1, C = 0)	SR	0002 (Z = 1, C = 0)

**Example 2: BSW.Z W2, W3 ; Set bit W3 in W2 to the
complement
; of the Z bit**

Before Instruction		After Instruction	
W2	E235	W2	E234
W3	0550	W3	0550
SR	0002 (Z = 1, C = 0)	SR	0002 (Z = 1, C = 0)

**Example 3: BSW.C [++W0], W6 ; Set bit W6 in [W0++] to the
value
; of the C bit**

Before Instruction		After Instruction	
W0	1000	W0	1002
W6	34A3	W6	34A3
Data	1002 2380	Data	1002 2388
SR	0001 (Z = 0, C = 1)	SR	0001 (Z = 0, C = 1)

BTG		Bit Toggle in Ws						
Syntax:	{label:}	BTG.b	Ws,	bit5				
		BTG{.w}	[Ws],					
		BTG.l	[Ws++],					
			[Ws--],					
			[++Ws],					
			[--Ws],					
			SR					
Operands:		Ws ∈ [W0 ... W15];						
		Byte: bit5 ∈ [0 ... 7];						
		Word: bit5 ∈ [0 ... 15];						
		Long word: bit5 ∈ [0 ... 31]						
Operation:		(Ws)[bit5] → Ws[bit5]						
Status Affected:		None (see note 2)						
Encoding:		S100	010b	bbbb	ssss	pppU	UUUU	UUUU LB00
Description:		Bit 'bit5' in register Ws is toggled. The 'S' bit selects instruction size. The 'L' and 'B' bits select operation data width. The 'b' bits define value or bit5 of the bit position to be cleared (bit5[4:0] for the 16-bit opcode) The 's' bits select the source/destination register. The 'p' bits select the source addressing mode.						
		Note:						
		1. When targeting the SR, a bit within the SR will be toggled as a result of the instruction operation.						
I-Words:		1 or 0.5						
Cycles:		1						

BTG	Bit Toggle f								
Syntax:	{label:}	BTG.b	f,	bit3					
Operands:	bit3 ∈ [0 ... 7]; f ∈ [0 ... 1MB]								
Operation:	(f)[bit3] → (f)[bit3]								
Status Affected:	None								
Encoding:	1100	010b	ffff	ffff	ffff	ffff	ffff	ffff	bb01
Description:	<p>Bit 'bit3' in file register f is toggled. The 'w' bits select value bit3 of the bit position to be cleared. The 'f' bits select the address of the file register.</p> <p>Notes:</p> <ol style="list-style-type: none"> 1. This instruction operates in Byte mode only. 2. The .b extension must be included with the opcode. 3. Accessible file address space is 1MB. 								
I-Words:	1								
Cycles:	1								

BTST		Bit Test in Ws		
Syntax:	{label:}	BTST.bC	Ws,	bit5
		BTST.bZ	[Ws],	
		BTST.{w}C	[Ws++],	
		BTST.{w}Z	[Ws--],	
		BTST.IC	[++Ws],	
		BTST.IZ	[--Ws],	
Operands:	Ws ∈ [W0 ... W15]; Byte: bit5 ∈ [0 ... 7]; Word: bit5 ∈ [0 ... 15]; Long word: bit5 ∈ [0 ... 31]			
Operation:	If ".Z" option, (Ws)[bit5] → Z If ".C" option, (Ws)[bit5] → C			
Status Affected:	C or Z			
Encoding:	S100	011b	bbbb	ssss pppU UUUU UUUG LB00
Description:	Bit 'bit5' in register Ws is tested. The Zero Flag contains the inversion of the bit or the Carry Flag contains the bit. The 'S' bit selects instruction size. The 'L' and 'B' bits select operation data width. The 'G' bit selects the Z or C flag bit as source (G = 0 selects Z flag). The 'b' bits define value or bit5 of the bit position to be cleared (bit5[4:0] for the 16-bit opcode). The 's' bits select the source/destination register. The 'p' bits select the source addressing mode.			
I-Words:	1 or 0.5			
Cycles:	1			

Example 1: BTST.C [W0++], #0x3 ; Set C = bit 3 in [W0]
; Post-increment W0

Before Instruction		After Instruction	
W0	1200	W0	1202
Data 1200	FFF7	Data 1200	FFF7
SR	0001 (C = 1)	SR	0000

Example 2: BTST.Z W0, #0x7 ; Set Z = complement of bit 7 in W0

Before Instruction		After Instruction	
W0	F234	W0	F234
SR	0000	SR	0002 (Z = 1)

BTST		Bit Test f	
Syntax:	{label:}	BTST.b	f, bit3
Operands:	bit3 ∈ [0 ... 7]; f ∈ [0 ... 1MB]		
Operation:	(f)[bit3] → Z		
Status Affected:	Z		
Encoding:	1100	011b	ffff ffff ffff ffff ffff bb01
Description:	<p>Bit 'bit3' in file register f is tested, the Zero Flag bit is set if it is zero and cleared otherwise. The file register contents are unchanged.</p> <p>The 'b' bits select value bit3 of the bit position to be cleared.</p> <p>The 'f' bits select the address of the file register.</p> <p>Notes:</p> <ol style="list-style-type: none"> 1. This instruction operates in Byte mode only. 2. The .b extension must be included with the opcode. 3. Accessible file address space is 1MB. 		
I-Words:	1		
Cycles:	1		

Example 1: BTST.B 0x1201, #0x3 ; Set Z = complement of bit 3 in 0x1201

Before Instruction		After Instruction	
Data 1200	F7FF	Data 1200	F7FF
SR	0000	SR	0002 (Z = 1)

Example 2: BTST 0x1302, #0x7 ; Set Z = complement of bit 7 in 0x1302

Before Instruction		After Instruction	
Data 1302	F7FF	Data 1302	F7FF
SR	0002 (Z = 1)	SR	0000

BTST		Bit Test/Set in Ws			
Syntax:	{label:}	BTST.bC	Ws,	bit5	
		BTST.bZ	[Ws],		
		BTST.{w}C	[Ws++]		
		BTST..{w}Z	[Ws--]		
		BTST.IC	[++Ws],		
		BTST..IZ	[--Ws],		
Operands:	Ws ∈ [W0 ... W15]; Byte: bit5 ∈ [0 ... 7]; Word: bit5 ∈ [0 ... 15]; Long word: bit5 ∈ [0 ... 31]				
Operation:	if ".Z" option, first (Ws)[bit5] → Z, then 1 → Ws[bit5] if ".C" option, first (Ws)[bit5] → C, then 1 → Ws[bit5]				
Status Affected:	C or Z				
Encoding:	S100	100b	bbbb	ssss	pppU UUUU UUG LB00
Description:	Bit 'bit5' in register Ws is tested and then set. For the ".Z" option, the Z Flag is set to the complement of the 'bit5' value prior to being set, and the C Flag is not modified. For the ".C" option, the C Flag is set to the 'bit5' value prior to being set, and the Z Flag is not modified. The 'S' bit selects instruction size. The 'L' and 'B' bits select operation data width. The 'G' bit selects the Z or C Flag bit as source (G = 0 selects Z Flag). The 'b' bits define value or bit5 of the bit position to be cleared. The 's' bits select the source/destination register. The 'p' bits select the source addressing mode.				
I-Words:	1 or 0.5				
Cycles:	1				

```

Example 1:      BTSTS.C [W0++], #0x3                ; Set C = bit 3 in [W0]
                                                         ; Set bit 3 in [W0] = 1
                                                         ; Post-increment W0
    
```

Before Instruction		After Instruction	
W0	1200	W0	1202
Data 1200	FFF7	Data 1200	FFFF
SR	0001 (C = 1)	SR	0000

```

Example 2:      BTSTS.Z W0, #0x7                ; Set Z = complement of bit 7
                                                         ; in W0, and set bit 7 in W0 = 1
    
```

Before Instruction		After Instruction	
W0	F234	W0	F2BC
SR	0000	SR	0002 (Z = 1)

BTSTS		Bit Test/Set f	
Syntax:	{label:}	BTSTS.b	f, bit3
Operands:	bit3 ∈ [0 ... 7]; f ∈ [0 ... 1MB]		
Operation:	First (f)[bit3] → Z, then 1 → (f)[bit3]		
Status Affected:	Z		
Encoding:	1100	100b	ffff ffff ffff ffff ffff bb01
Description:	Bit 'bit3' in file register f is tested and then set. The Z Flag is set to the complement of the 'bit3' value prior to being set. The 'w' bits select value bit3 of the bit position to be test/set. The 'f' bits select the address of the file register.		
	Notes:		
	1. This instruction operates in Byte mode only. 2. The .b extension must be included with the opcode. 3. Accessible file address space is 1MB.		
I-Words:	1		
Cycles:	1		

Example 1: BTSTS.B 0x1201, #0x3 ; Set Z = complement of bit 3 in 0x1201, ; then set bit 3 of 0x1201 = 1

Before Instruction		After Instruction	
Data 1200	F7FF	Data 1200	FFFF
SR	0000	SR	0002 (Z = 1)

Example 2: BTSTS 0x808, #15 ; Set Z = complement of bit 15 in 0x808, ; then set bit 15 of 0x808 = 1

Before Instruction		After Instruction	
RAM300	8050	RAM300	8050
SR	0002 (Z = 1)	SR	0000

BTST		Bit Test in Ws		
Syntax:	{label:}	BTST.bC	Ws,	Wb
		BTST.bZ	[Ws],	
		BTST.{w}C	[Ws++]	
		BTST.{w}Z	[Ws--],	
		BTST.IC	[++Ws],	
		BTST.IZ	[--Ws],	
Operands:		Wb ∈ [W0 ... W14]; Ws ∈ [W0 ... W15]		
Operation:		if ".Z" option, (Ws)<(Wb)> → Z if ".C" option, (Ws)<(Wb)> → C		
Status Affected:		C or Z		
Encoding:		S100	110L	www ssss pppU UUUU UUG BU00
Description:		<p>The bit number defined in Wb is tested in source register Ws. For byte, word and long word operations, the target bit number is defined by Wb[2:0], Wb[3:0] and Wb[4:0], respectively. Any bit within Wb, beyond those bits required to select the target bit, will be ignored and may be set to any value.</p> <p>For the ".Z" option, the Z Flag is set to the complement of the bit value tested, and the C Flag is not modified. For the ".C" option, the C Flag is set to the bit value tested, and the Z Flag is not modified. Wb[31:5] are ignored and may be set to any value.</p> <p>The 'S' bit selects instruction size.</p> <p>The 'L' and 'B' bits select operation data width.</p> <p>The 'w' bits select the bit select register.</p> <p>The 'G' bit selects the Z or C Flag bit as source (G = 0 selects Z Flag).</p> <p>The 's' bits select the source register.</p> <p>The 'p' bits select the source addressing mode.</p>		
I-Words:		1 or 0.5		
Cycles:		1		

Example 1:	BTST.C W2, W3	; Set C = bit W3 of W2
	Before Instruction	After Instruction
	W2 F234	W2 F234
	W3 2368	W3 2368
	SR 0001 (C = 1)	SR 0000

Example 2:	BTST.Z [W0++], W1	; Set Z = complement of bit W1 in [W0], ; Post-increment W0
	Before Instruction	After Instruction
	W0 1200	W0 1202
	W1 CCC0	W1 CCC0
	Data 1200 6243	Data 1200 6243
	SR 0002 (Z = 1)	SR 0000

BRA Z		Branch if Zero						
Syntax:	{label:}	BRA	Z,	Label				
Operands:	Label is resolved by the linker to a signed word offset (slit20)							
Operation:	Condition = Z If (condition) then { If slit20 = 1 then skip next (16-bit) instruction Else if (slit20 = 2 && next_op[31] = 1) then skip next (32-bit) instruction Else (PC+4) + 2*slit20 → PC } Else no branch							
Status Affected:	None							
Encoding:	1010	011U	nnnn	nnnn	nnnn	nnnn	nnnn	1010
Description:	<p>If the branch condition is met, then the instruction will either skip the next 16-bit or 32-bit instruction, or it will branch to any size of instruction with a forward or backward range of 1MB. If the 2's complement byte offset value '2*slit20' (the PC offset) equals two, the conditional branch will execute as a conditional skip of one 16-bit instruction. This instruction will be speculatively executed as not skipped until such time that the branch decision can be determined.</p> <p>If the 2's complement byte offset value '2*slit20' (the PC offset) equals four and the instruction after the branch is a 32-bit opcode (see note), the conditional branch will execute as a conditional skip of that 32-bit instruction. This instruction will be speculatively executed as not skipped until such time that the branch decision can be determined.</p> <p>If requirements for a conditional skip are not met, the 2's complement byte offset value '2*slit20' is added to the PC to create a new PS word address. Since the PC will have incremented to fetch the next instruction, the new address will be (PC+4) + 2*slit20.</p> <p>Branch prediction is based on the direction of the branch. If the branch is backwards (negative), it will be predicted as taken. If the branch is forwards (positive), it will be predicted as not taken. The two instructions that follow the branch will then be speculatively executed in the predicted path until such time that the actual branch decision can be assessed. A correctly predicted branch will continue instruction execution in the same path unabated. An incorrectly predicted branch will abort the speculatively executed instructions and start execution from the correct path.</p> <p>The 'n' bits are a signed literal that specifies the number of PS words offset from (PC+4).</p> <p>Note: Should the byte offset equal four and instruction after the branch is a 16-bit opcode, a branch will occur (over the next two 16-bit ops) if the condition is met.</p>							
I-Words:	1							
Cycles:	1 (2 or 3)							
	Note: The branch target instruction fetch is not executed if an exception is pending, making effective instruction execution time one cycle.							

Example:1	Address	Label	Instruction	Comment
	0x804000	-	BRA Z, _CHECK_FAIL	; Branch if Z == 1, to 0x804030(_CHECK_FAIL)
	0x804004	_PASS_CONDITION:	SL.l w5, w6	
	
	
	
	0x804030	_CHECK_FAIL:	MOV.l SR, W6	; _CHECK_FAIL SubRoutine
	...		CP w6, w7	
	
		Before execution		After execution
		PC 0x804000		PC 0x804030
		w15 0x4500		w15 0x4500
		SR[7:0] 8'b00000010	(Z = 1)	SR[7:0] 8'b00000010 (Z = 1)

4.5. Instruction Descriptions (C to DTB)

CALL	Call Subroutine							
Syntax:	{label:}	CALL						lit24
Operands:	lit24 ∈ [0 ... 16MB]							
Operation:	(PC) + 4 → PC, (8'b0, PC[23:2]) → TOS[31:2]; 2'b00 → TOS[1:0], (W15) + 4 → W15, lit24 → PC[23:0]; NOP → Instruction Register							
Status Affected:	None							
Encoding:	1101	111n	nnnn	nnnn	nnnn	nnnn	nn10	
Description:	Subroutine call to any address within all of executable memory address space. A call to either a 32-bit or 16-bit instruction is permitted. The long word aligned return address (PC+4) is pushed onto the system stack. The 24-bit value 'lit24' is then loaded into the PC (the opcode does not store the LSB which is always 1'b0). The 'n' bits form the target address. Note: The (byte) PC address is always either word or long word aligned. The opcode does not store the LSB because it is always 1'b0.							
I-Words:	1							
Cycles:	1							

Example:1	Address	Label	Instruction	Comment
	0x804000	-	CALL _CHECK_FAIL	; Calls function in address 0x805000(_CHECK_FAIL)
	...			
	0x805000	_CHECK_FAIL	MOV.I SR, W6	; _CHECK_FAIL SubRoutine
	...		CP w6, w7	
	
	Before execution		After execution	
	PC	0x804000	PC	0x805000
	w15	0x4500	w15	0x4504
	Data @4500	0x0000	Data @4500	0x804004
	SR	0x00000000	SR	0x00000000

CALL Call Indirect Subroutine

Syntax: {label;} CALL Wns

Operands: Wns ∈ [W0...W14]

Operation: (PC) + 2 → PC,
 (8'b0, PC[23:2]) → TOS[31:2]; 2'b00 → TOS[1:0],
 (W15)+4 → W15,
 Wns[23:0] → PC[23:0];
 NOP → Instruction Register.

Status Affected: None

Encoding: 1101 011U UUUU ssss UUUU UUUU UUUU 1110

Description: Indirect subroutine call of any instruction address (16-bit or 32-bit) within program memory using a computed call PS (word) address.
 The long word aligned return address (PC+4) is pushed onto the system stack. The 24-bit value (Wns[23:0]) is then loaded into the PC[23:0]. Wns must therefore contain a PS byte address.
 The value of Wns[0] is ignored, and PC[0] is always set to 1'b0.
 The 's' bits specify the source register.

Note:

- If Wns[31:24] != 8'h00, an address error trap will be initiated.

I-Words: 1

Cycles: 2

Note: The call target instruction fetch is not executed if an exception is pending, making effective instruction execution time one cycle.

Example:1	Address	Label	Instruction	Comment
	0x803FFC	-	MOV.I #_CHECK_FAIL, W0	
	0x804000	-	CALL W0	; Calls function in address 0x805000(_CHECK_FAIL)
	...			
	0x805000	_CHECK_FAIL:	MOV.I SR, W6	; _CHECK_FAIL SubRoutine
	...		CP w6, w7	
	
	Before execution			After execution
	PC	0x804000		PC 0x805000
	W0	0x805000		PC 0x805000
	w15	0x4500		w15 0x4504
	Data @4500	0x0000		Data @4500 0x804004
	SR	0x00000000		SR 0x00000000

CLR		Clear Accumulator			
Syntax: {label}	CLR	A			
		B			
Operands:	None				
Operation:	0 → ACC(A or B)				
Status Affected:	OA,SA or OB,SB				
Encoding:	0111	001A	UUUU	1100	
Description:	Clear the specified accumulator (A or B). The 'A' bit selects the accumulator to clear.				
I-Words:	0.5				
Cycles:	1				

Example 1:		CLR A; Clear ACCA			
	Before Instruction		After Instruction		
ACCA	0x00_0012		ACCA	0x00_0000	
	_3412_452			_0000_000	
	4_1234			0_0000	

CLR		Clear f	
Syntax:	{label:}	CLR.b	f
		CLR{.w}	
		CLR.l	
Operands:	f ∈ [0 ... 1MB]		
Operation:	0x00000000 → file register for long operation 0x0000 → file register for word operation 0x00 → file register for byte operation		
Status Affected:	None		
Encoding:	1010	011L	ffff ffff ffff ffff ffff B101
Description:	Clear the file register. The 'L' and 'B' bits select operation data width. The 'f' bits select the address of the file register.		
	Notes:		
	1. Same flow as any other file operation with D-bit (opcode[2]) set to 1.		
	2. Accessible file address space is 1MB.		
I-Words:	1		
Cycles:	1		

Example 1: CLR.B RAM200 ; Clear RAM200 (Byte mode)

Before Instruction		After Instruction	
RAM200	8009	RAM200	8000
SR	0000	SR	0000

Example 2: CLR WREG ; Clear WREG (Word mode)

Before Instruction		After Instruction	
WREG	0600	WREG	0000
SR	0000	SR	0000

CLRWDT	Clear Watchdog Timer			
Syntax:	{label:}	CLRWDT		
Operands:	None			
Operation:	0 → WDT Reg			
Status Affected:	None			
Encoding:	0111	001U	UUUU	0101
Description:	Clear the WatchDog Timer register.			
I-Words:	0.5			
Cycles:	1			

COM		Complement Ws			
Syntax:	{label:}	COM.b	Ws,	Wd	
		COM.bz	[Ws],	[Wd]	
		COM{.w}	[Ws++],	[Wd++]	
		COM.l	[Ws--],	[Wd--]	
			[++Ws],	[++Wd]	
			[--Ws],	[--Wd]	
Operands:	Ws ∈ [W0 ... W15]; Wd ∈ [W0 ... W15]				
Operation:	(Ws) → Wd				
Status Affected:	Z, N				
Encoding:	S111	100L	dddd	ssss	pppq qqUU UUUU BU00
Description:	<p>Compute the 1's complement of the contents of the source register Ws and place the result in the destination register Wd.</p> <p>The 'S' bit selects instruction size.</p> <p>The 'L' and 'B' bits select operation data width.</p> <p>The 's' bits select the source register.</p> <p>The 'd' bits select the destination register.</p> <p>The 'p' bits select the source addressing mode.</p> <p>The 'q' bits select the destination addressing mode.</p>				
I-Words:	1 or 0.5				
Cycles:	1				

Example 1: COM.B [W0++], [W1++]; COM [W0] and store to [W1] (Byte mode); Post-increment W0, W1

Before Instruction		After Instruction	
W0	2301	W0	2302
W1	2400	W1	2401
Data 2300	5607	Data 2300	5607
Data 2400	ABCD	Data 2400	ABA9
SR	0000	SR	0008 (N = 1)

Example 2: COM W0, [W1++]; COM W0 and store to [W1] (Word mode); Post-increment W1

Before Instruction		After Instruction	
W0	D004	W0	D004
W1	1000	W1	1002
Data 1000	ABA9	Data 1000	2FFB
SR	0000	SR	0000

COM		Complement f						
Syntax:	{label:}	COM.b	f	{Wnd}	{WREG}			
		COM.bz						
		COM{.w}						
		COM.l						
Operands:		f ∈ [0 ... 64KB]; Wnd ∈ [W0 ... W14]						
Operation:		(f) → destination designated by D						
Status Affected:		Z, N						
Encoding:		1101	100L	dddd	ffff	ffff	ffff	ffff BD01
Description:		Compute the 1's complement of the contents of the file register and place the result in the destination designated by D. If the optional Wnd is specified, D=0 and store result in Wnd; otherwise, D=1 and store result in the file register. The 'L' and 'B' bits select operation data width. The 'D' bit selects the destination. The 'f' bits select the address of the file register. The 'd' bits select the Working register.						
I-Words:		1						
Cycles:		1						

Example 1: COM.b RAM200 ; COM RAM200 (Byte mode)

Before Instruction		After Instruction		
RAM200	80FF	RAM200	8000	
SR	0000	SR	0002	(Z)

Example 2: COM RAM400, WREG ; COM RAM400 and store to WREG ; (Word mode)

Before Instruction		After Instruction		
WREG	1211	WREG	F7DC	
RAM400	0823	RAM400	0823	
SR	0000	SR	0008	(N = 1)

CP		Compare Wb with Ws, Set Status Flags							
Syntax:	{label:}	CP.b	Wb,	Ws					
		CP{.w}		[Ws]					
		CP.l		[Ws++]					
				[Ws--]					
				[++Ws]					
				[--Ws]					
Operands:		Wb ∈ [W0 ... W15]; Ws ∈ [W0 ... W15]							
Operation:		(Wb) - (Ws)							
Status Affected:		C, N, OV, Z							
Encoding:		S011	110L	www	ssss	pppU	UUUU	UUUU	BU00
Description:		Compute (Wb) - (Ws), then set flags but do not store result. Equivalent to SUB instruction (without a destination result write). The 'S' bit selects instruction size. The 'L' and 'B' bits select operation data width. The 'w' bits select the Wb source register. The 's' bits select the Ws source register. The 'p' bits select the source addressing mode.							
I-Words:		1 or 0.5							
Cycles:		1							

Example 1: CP.B W0, [W1++] ; Compare [W1] with W0 (Byte mode) ; Post-increment W1

Before Instruction		After Instruction	
W0	ABA9	W0	ABA9
W1	2000	W1	2001
Data 2000	D004	Data 2000	D004
SR	0000	SR	0009 (N, C = 1)

Example 2: CP.W5, W6 ; Compare W6 with W5 (Word mode)

Before Instruction		After Instruction	
W5	2334	W5	2334
W6	8001	W6	8001
SR	0000	SR	000C (N, OV = 1)

CPB		Compare Wb with Ws with Borrow, Set Status Flags						
Syntax:	{label:}	CPB.b	Wb,	Ws				
		CPB{.w}		[Ws]				
		CPB.l		[Ws++]				
				[Ws--]				
				[++Ws]				
				[--Ws]				
Operands:		Wb ∈ [W0 ... W15]; Ws ∈ [W0 ... W15]						
Operation:		(Wb) - (Ws) - (C)						
Status Affected:		C, N, OV, Z						
Encoding:		S011	111L	www	sss	pppU	UUUU	UUUU BU00
Description:		<p>Compute (Wb) - (Ws) - (C), then set flags but do not store result. Equivalent to SUBB instruction without a destination result write.</p> <p>The Z bit is “sticky” (can only be cleared).</p> <p>The ‘S’ bit selects instruction size.</p> <p>The ‘L’ and ‘B’ bits select operation data width.</p> <p>The ‘w’ bits select the Wb source register.</p> <p>The ‘s’ bits select the Ws source register.</p> <p>The ‘p’ bits select the source addressing mode.</p>						
I-Words:		1 or 0.5						
Cycles:		1						

CPB	Compare Ws with lit13 with Borrow, Set Status Flags						
Syntax:	{label:}	CPB.b	Ws,	lit13			
		CPB{.w}	[Ws],				
		CPB.l	[Ws++],				
			[Ws--],				
			[++Ws],				
			--Ws],				
Operands:	Ws ∈ [W0 ... W15]; lit13 ∈ [0 ... 8191] (32-bit opcode); lit4 ∈ [0 ... 15] (16-bit opcode) ¹						
Operation:	(Ws) - lit13 - (C) or (Ws) - lit4 - (C) ¹ Note: The literal is zero-extended to the selected data size of the operation						
Status Affected:	C, N, OV, Z						
Encoding:	s011	101L	kkkk	ssss	pppk	kkkk	kkkk BU00
Description:	Zero-extend literal then compute (Ws) - literal - (C). Set flags but do not store result. The Z bit is sticky (can only be cleared). The 'L' and 'B' bits select operation data width. The 'p' bits select the source addressing mode. The 's' bits select the source register. The 'k' bits provide the literal operand. lit13[12:0] = Opcode[12:4], Opcode[23:20] lit4[3:0] = Opcode[23:20]						
I-Words:	1 or 0.5						
Cycles:	1						

CP	Compare Ws with lit13, Set Status Flags			
Syntax:	{label:}	CP.b	Ws,	lit13
		CP{.w}	[Ws],	
		CP.l	[Ws++],	
			[Ws--],	
			[++Ws],	
			--Ws],	
Operands:	Ws ∈ [W0 ... W15]; lit13 ∈ [0 ... 8191] (32-bit opcode); lit4 ∈ [0 ... 15] (16-bit opcode) ¹			
Operation:	(Ws) - lit13 (32-bit opcode) or (Ws) - lit4 (16-bit opcode) ¹ Note: The literal is zero-extended to the selected data size of the operation			
Status Affected:	C, N, OV, Z			
Encoding:	s011	100L	kkkk	ssss pppk kkkk kkkk BU00
Description:	Zero-extend literal as necessary, then compute (Ws) - literal. Set flags but do not store result. The Z bit is sticky (can only be cleared). The 'L' and 'B' bits select operation data width. The 'p' bits select the source addressing mode. The 's' bits select the source register. The 'k' bits provide the literal operand. lit13[12:0] = Opcode[12:4], Opcode[23:20] lit4[3:0] = Opcode[23:20]			
I-Words:	1 or 0.5			
Cycles:	1			

CPB	Compare Wb with lit16 with Borrow, Set Status Flags								
Syntax:	{label:}	CPB.b	Wb,	lit16					
		CPB{.w}							
		CPB.l							
Operands:	Wb ∈ [W0 ... W15]; lit16 ∈ [0 ... 65535]								
Operation:	(Wb) - lit16 - (C)								
Status Affected:	C, N, OV, Z								
Encoding:	1100	011L	www	kkk	kkk	kkk	kkk		B110
Description:	<p>Compute (Wb) - lit16 - (C), set flags but do not store result. The Z bit is "sticky" (can only be cleared). The 'L' and 'B' bits select operation data width. The 'w' bits select the source register. The 'k' bits provide the literal operand.</p>								
I-Words:	1								
Cycles:	1								

CP	Compare f with Ws, Set Status Flags							
Syntax:	{label:}	CP.b	f,	Ws				
		CP{.w}						
		CP.l						
Operands:	f ∈ [0 ...64KB]; Ws ∈ [W0 ... W15]							
Operation:	(f) - (Ws)							
Status Affected:	C, N, OV, Z							
Encoding:	1010	101L	ssss	ffff	ffff	ffff	ffff	BU01
Description:	<p>Compute (f) - (Ws), set flags but do not store result. Equivalent to SUBWF instruction with a stack sink destination ([W15]).</p> <p>The 'L' and 'B' bits select operation data width.</p> <p>The 'f' bits select the address of the file register.</p> <p>The 's' bits select the Working register.</p>							
I-Words:	1							
Cycles:	1							

CP0		Compare f with Zero, Set Status Flags	
Syntax:	{label:}	CP0.b	f
		CP0{.w}	
		CP0.l	
Operands:	f ∈ [0 ... 1MB]		
Operation:	Long: (f) - 0x0000000		
	Word: (f) - 0x0000		
	Byte: (f) - 0x00		
Status Affected:	C, N, OV, Z		
Encoding:	1010	100L	ffff ffff ffff ffff BU01
Description:	<p>Compute (f) minus zero value for selected data size, set flags but do not store result. The C bit is always set, and OV is always cleared by this operation.</p> <p>The 'L' and 'B' bits select operation data width.</p> <p>The 'f' bits select the address of the file register.</p> <p>Accessible file address space is 1 MB.</p>		
I-Words:	1		
Cycles:	1		

Example 1: CP0.B RAM100 ; Compare RAM100 with 0x0 (Byte mode)

Before Instruction		After Instruction	
RAM100	44C3	RAM100	44C3
SR	0000	SR	0009 (N, C = 1)

Example 2: CP0 0x1FFE ; Compare (0x1FFE) with 0x0 (Word mode)

Before Instruction		After Instruction	
Data 1FFE	0001	Data 1FFE	0001
SR	0000	SR	0001 (C = 1)

CPB	Compare f with Ws with Borrow, Set Status Flags								
Syntax:	{label:}	CPB.b	f,	Ws					
		CPB{.w}							
		CPB.l							
Operands:	f ∈ [0 ...64KB]; Ws ∈ [W0 ... W15]								
Operation:	(f) - (Ws) - (C)								
Status Affected:	C, N, OV, Z								
Encoding:	1010	110L	ssss	ffff	ffff	ffff	ffff	ffff	BU01
Description:	<p>Compute (f) - (Ws) - (C), set flags but do not store result. Equivalent to SUBBWF instruction with a stack sink destination write ([W15]).</p> <p>The Z bit is "sticky" (can only be cleared).</p> <p>The 'L' and 'B' bits select operation data width.</p> <p>The 'f' bits select the address of the file register.</p> <p>The 's' bits select the Working register.</p>								
I-Words:	1								
Cycles:	1								

CP	Compare Wb with lit16, Set Status Flags							
Syntax:	{label:}	CP.b	Wb,	lit16				
		CP{.w}						
		CP.l						
Operands:	Wb ∈ [W0 ... W15]; lit16 ∈ [0 ... 65535]							
Operation:	(Wb) - lit16							
Status Affected:	C, N, OV, Z							
Encoding:	1100	010L	www	kkk	kkk	kkk	kkk	B110
Description:	<p>Compute (Wb) - lit16, set flags but do not store result. The 'L' and 'B' bits select operation data width. The 'w' bits select the source register. The 'k' bits provide the literal operand.</p>							
I-Words:	1							
Cycles:	1							

CTXTSWP	CPU Register Context Swap Literal		
Syntax:	{label:}	CTXTSWP lit3	
Operands:	lit3 ∈ [0 ... 7]		
Operation:	Switch CPU register context to context defined by lit3 lit3 → SR.CTX[2:0]		
Status Affected:	None		
Encoding:	0111	001U	Ukkk 0110
Description:	<p>This instruction will force a CPU register context switch from the current context to the target context defined by value lit3. If supported, coprocessor contexts will also be switched accordingly. A context switch will update the Current Context Identifier (SR.CTX[2:0]) to reflect the new active CPU register context.</p> <p>The 'k' bits select the target register context.</p>		
I-Words:	0.5		
Cycles:	2		

CTXTSWP		CPU Register Context Swap Ws						
Syntax:	{label:}	CTXTSWP Wns						
Operands:	Wns ∈ [W0 ... W14]							
Operation:	Switch CPU register context to context defined in Wns[2:0] ¹ Wns[2:0] → SR.CTX[2:0]							
Status Affected:	None							
Encoding:	1101	100U	UUUU	ssss	UUUU	UUUU	UUUU	U110
Description:	<p>This instruction will force a CPU register context switch (W0 through W7) from the current context to the target context defined by the contents of Wns[2:0]. Supported register contexts in any instantiated coprocessors will also be switched.</p> <p>A context switch will update the Current Context (SR.CTX[2:0]) to reflect the new active CPU register context.</p> <p>The 's' bits select the source register.</p> <p>Note:</p> <ol style="list-style-type: none"> The contents of Wns[31:3] are ignored. 							
I-Words:	1							
Cycles:	2							

DEC		Decrement f					
Syntax:	{label:}	DEC.b	f	{Wnd}	{WREG}		
		DEC.bz					
		DEC{.w}					
		DEC.l					
Operands:	f ∈ [0 ... 64KB]; Wnd ∈ [W0 ... W14]						
Operation:	(f) - 1 → destination designated by D						
Status Affected:	C, N, OV, Z						
Encoding:	1101	011L	dddd	ffff	ffff	ffff	ffff BD01
Description:	<p>Subtract one from the contents of the file register and place the result in the destination designated by D. If the optional Wnd is specified, D=0 and store result in Wnd; otherwise, D=1 and store result in the file register.</p> <p>The 'L' and 'B' bits select operation data width.</p> <p>The 'D' bit selects the destination.</p> <p>The 'f' bits select the address of the file register.</p> <p>The 'd' bits select the Working register.</p>						
I-Words:	1						
Cycles:	1						

Example 1: DEC.B 0x200 ; Decrement (0x200) (Byte mode)

Before Instruction		After Instruction		
Data 200	80FF	Data 200	80FE	
SR	0000	SR	0009	(N, C = 1)

Example 2: DEC RAM400, WREG ; Decrement RAM400 and store to WREG ; (Word mode)

Before Instruction		After Instruction	
WREG	1211	WREG	0822
RAM400	0823	RAM400	0823
SR	0000	SR	0000

DEC2	Decrement f by 2						
Syntax:	{label:}	DEC2.b	f	{Wnd}	{WREG}		
		DEC2.bz					
		DEC2{.w}					
		DEC2.l					
Operands:	f ∈ [0 ... 64KB]; Wnd ∈ [W0 ... W14]						
Operation:	(f) - 2 → destination designated by D						
Status Affected:	C, N, OV, Z						
Encoding:	1101	111L	dddd	ffff	ffff	ffff	BD01
Description:	<p>Subtract two from the contents of the file register and place the result in the destination designated by D. If the optional Wnd is specified, D=0 and store result in Wnd; otherwise, D=1 and store result in the file register.</p> <p>The 'L' and 'B' bits select operation data width.</p> <p>The 'D' bit selects the destination.</p> <p>The 'f' bits select the address of the file register.</p> <p>The 'd' bits select the Working register.</p>						
I-Words:	1						
Cycles:	1						

DISICTL	Disable Interrupts Control Literal								
Syntax:	{label:}	DISICTL	lit3	{ ,Wd}	{ ,[Wd]}	{ ,[Wd++]}	{ ,[Wd--]}	{ ,[++Wd]}	{ ,[--Wd]}
Operands:	lit3 ∈ [0 ... 7]; Wd ∈ [W0 ... W15]								
Operation:	Disable interrupts at or below IPL threshold (IPLT[2:0]) defined by lit3 Setting lit3 = 0 will enable all interrupt levels up to and including those at SR.IPL[2:0]. If Wd declared, zero extended prior IPLT[2:0] → Wd[31:0]								
Status Affected:	None								
Encoding:	1101	110U	dddd	UUUU	UUUq	qqUU	Ukkk	0W10	
Description:	<p>This instruction disables interrupts at or below the IPL threshold (IPLT[2:0]) defined by lit3, effective starting from the subsequent instruction. Traps cannot be inhibited by this instruction. The current DISICTL 3-bit IPLT is memory mapped (DISIIPL.IPLT[2:0]) and can be read by the user at any time. A write to DISIIPL will have no effect.</p> <p>In addition, the IPLT established prior to DISICTL execution may be optionally written to destination Wd if a destination is declared (W = 1). The prior IPLT[2:0] is zero extended to 32-bits prior to being written. If a destination operand is not declared, nothing will be written (W = 0). This facilitates nesting of DISICTL and/or DISICTLW instructions.</p> <p>The 'W' bit determines if a destination write is required. The 'k' bits are an unsigned literal that specifies the DISICTL IPL threshold. The 'd' bits select the destination register. The 'q' bits select the destination addressing mode.</p> <p>Note: SR.IPL[2:0] is not modified by this instruction.</p>								
I-Words:	1								
Cycles:	1								

DISICTL	Disable Interrupts Control Wns								
Syntax:	{label:}	DISICTL	Wns	{ ,Wd}	{ ,[Wd]}	{ ,[Wd++]}	{ ,[Wd--]}	{ ,[++Wd]}	{ ,[--Wd]}
Operands:	Wns ∈ [W0 ... W14]; Wd ∈ [W0 ... W15]								
Operation:	Disable interrupts at or below IPL threshold (IPLT[2:0]) defined by Wns[2:0] Wns[2:0] = 0 will enable all interrupt levels If Wd declared, zero extended prior IPLT[2:0] → Wd[31:0]								
Status Affected:	None								
Encoding:	1101	110U	dddd	ssss	UUUq	qqUU	UUUU	1W10	
Description:	<p>This instruction disables interrupts at or below the IPL threshold (IPLT[2:0]) defined by the LS 3-bits of source Wns (remaining MSBs of Wns are ignored), effective starting from the subsequent instruction. Traps cannot be inhibited by this instruction.</p> <p>The current DISICTLW 3-bit IPLT is memory mapped (DISIPL.IPLT[2:0]) and can be read by the user at any time. A write to DISIPL will have no effect.</p> <p>In addition, the IPLT established prior to DISICTL execution may be optionally written to destination Wd if a destination is declared (W = 1). The prior IPLT[2:0] is zero extended to 32-bits prior to being written. If a destination operand is not declared, nothing will be written (W = 0). This facilitates nesting of DISICTL(W) instructions.</p> <p>This instruction can be used (optionally in conjunction with DISICTLR) to control the impact of system interrupts.</p> <p>The 'W' bit determines if a destination write is required.</p> <p>The 's' bits select the source register.</p> <p>The 'd' bits select the destination register.</p> <p>The 'q' bits select the destination addressing mode.</p> <p>Note: SR.IPL[2:0] is not modified by this instruction.</p>								
I-Words:	1								
Cycles:	1								

DIVF		Signed Fractional 16/16 and 32/16 Divide		
Syntax:	{label:}	DIVF.w	Wm	Wn
		DIVF.l		
Operands:	Wn ∈ [W0 ... W14]; Wm ∈ [W0 ... W13]			
Operation:	DIVF.w (16/16): Wm[15:0] = Dividend, Wn[15:0] = Divisor: Wm << 16; 16'b0 → Wm[15:0]; Wm / Wn → 16'b0, Wm[15:0]; Remainder → 16'b0, W(m+1)[15:0]			
	DIVF.l (32/16): Wm[31:0] = Dividend, Wn[15:0] = Divisor: Wm / Wn → 16'b0, Wm[15:0]; Remainder → 16'b0, W(m+1)[15:0]			
Status Affected:	C, N, OV, Z			
Encoding:	1110	100L	www	sss
			UUUU	UUUU
			UUUU	1011
Description:	Iterative, signed fractional 32-bit (or 16-bit) by 16-bit divide to a 16-bit quotient and a 16-bit remainder, both of which are zero-extended prior to being written to Wm and W(m+1), respectively. The sign of the remainder will be the same as that of the dividend. The 16-bit by 16-bit divide scales the dividend to become a 32-bit fractional value prior to executing the divide.			
	This instruction must be executed six times to generate the correct quotient and remainder. This may only be achieved by executing a REPEAT with an iteration count of five (i.e. 5+1 iterations in all) and the DIVF.x instruction as its target. The REPEAT loop may be interrupted at any iteration boundary.			
	C is modified as per the divide algorithm. Z is set if the remainder is clear. Z is cleared otherwise. N is set if the remainder is negative. N is cleared otherwise. OV is set if the divide will result in an overflow. The quotient and remainder will be deterministic but meaningless.			
	The 'w' bits select the source (dividend) register. The 's' bits select the source (divisor) register.			
	Notes:			
	1. The divisor is tested for zero during the first iteration. An attempt to divide by zero will initiate an arithmetic error trap during the first cycle of DIVF.x execution.			
	2. Wn cannot share the same W-reg with Wm or W(m+1).			
I-Words:	1			
Cycles:	6			

Example:1	Address	Label	Instruction	Comment
	0x804000	-	REPEAT #5	; Execute DIV 5 times.
	0x804004	-	DIVF.l w4, w8	;Fractional Divide contents of W4 by contents of W5
	Before execution		After execution	
	w4	0x1001	w4	0x2000
	w8	0x4000	w8	0x4000
	w5	0x0000	w5	0x0001
	SR	0x00000000	SR	0x00000000

DIVFL		Signed Fractional 32/32 Divide			
Syntax:	{label:}	DIVFL	Wm	Wn	
Operands:	Wn ∈ [W0 ... W14]; Wm ∈ [W0 ... W13]				
Operation:	32/32; Wm = Dividend, Wn = Divisor; Wm / Wn → Wm[31:0]; Remainder → W(m+1)[31:0]				
Status Affected:	C, N, OV, Z				
Encoding:	1110	101U	www	sss	UUUU UUUU UUUU 1011
Description:	<p>Iterative, signed fractional 32-bit by 32-bit divide to a 32-bit quotient and a 32-bit remainder. The sign of the remainder will be the same as that of the dividend.</p> <p>This instruction must be executed ten times to generate the correct quotient and remainder. This may only be achieved by executing a REPEAT with an iteration count of nine (i.e. 9+1 iterations in all) and the DIVFL instruction as its target. The REPEAT loop may be interrupted at any iteration boundary.</p> <p>C is modified as per the divide algorithm. Z is set if the remainder is clear. Z is cleared otherwise. N is set if the remainder is negative. N is cleared otherwise. OV is set if the divide will result in an overflow. The quotient and remainder will be deterministic but meaningless.</p> <p>The 'w' bits select the source (dividend) register. The 's' bits select the source (divisor) register.</p> <p>Notes:</p> <ol style="list-style-type: none"> 1. The divisor is tested for zero during the first iteration. An attempt to divide by zero will initiate an arithmetic error trap during the first cycle of DIVFL execution. 2. Wn cannot share the same W-reg with Wm or W(m+1). 				
I-Words:	1				
Cycles:	10				

DIVS		Signed Integer 16/16 and 32/16 Divide							
Syntax:	{label:}	DIVS.w	Wm,	Wn					
		DIVS.l							
Operands:		Wn ∈ [W0 ... W14], Wm ∈ [W0 ... W13]							
Operation:		DIVS.w (16/16): Wm[15:0] = Dividend, Wn[15:0] = Divisor: {16{Wm[15]}}, Wm[15:0] → Wm[31:0]; Wm / Wn → 16'b0, Wm[15:0]; Remainder → 16'b0, W(m+1)[15:0]							
		DIVS.l (32/16): Wm[31:0] = Dividend, Wn[15:0] = Divisor: Wm / Wn → 16'b0, Wm[15:0]; Remainder → 16'b0, W(m+1)[15:0]							
Status Affected:		C, N, OV, Z							
Encoding:		1110	100L	www	sss	UUUU	UUUU	UUUU	0011
Description:		Iterative, signed integer 32-bit (or 16-bit) by 16-bit divide to a 16-bit quotient and a 16-bit remainder, both of which are zero-extended to 32-bits prior to being written to Wm and W(m+1), respectively. The sign of the remainder will be the same as that of the dividend. The 16-bit by 16-bit divide sign-extends the dividend prior to executing the divide. This instruction must be executed six times to generate the correct quotient and remainder. This may only be achieved by executing a REPEAT with an iteration count of five (i.e. 5+1 iterations in all) and the DIVS instruction as its target. The REPEAT loop may be interrupted at any iteration boundary. C is modified as per the divide algorithm. Z is set if the remainder is clear. Z is cleared otherwise. N is set if the remainder is negative. N is cleared otherwise. OV is set if the divide will result in an overflow. OV is cleared otherwise. The quotient and remainder will be deterministic but meaningless. The 'L' bit selects 32-bit or 16-bit dividend size. The 'w' bits select the source (dividend) register. The 's' bits select the source (divisor) register.							
		Notes:							
		1. The divisor is tested for zero during the first iteration. An attempt to divide by zero will initiate an arithmetic error trap during the first cycle of DIVS.x 2. Wn cannot share the same W-reg with Wm or W(m+1).							
I-Words:		1							
Cycles:		6							

Example:1	Address	Label	Instruction	Comment
	0x804000	-	REPEAT #5	; Execute DIV 5 times.
	0x804004	-	DIVS.l w4, w8	;Divide contents of W4 bycontents of W5
	Before execution		After execution	
	w4	0x3000	w4	0x013B
	w8	0x27	w8	0x27
	w5	0x0000	w5	0x0003
	SR	0x00000000	SR	0x00000000

DIVSL		Signed Integer 32/32 Divide					
Syntax:	{label:}	DIVSL	Wm,	Wn			
Operands:	$Wn \in [W0 \dots W14], Wm \in [W0 \dots W13]$						
Operation:	32/32; $Wm = \text{Dividend}, Wn = \text{Divisor}$ $Wm / Wn \rightarrow Wm; \text{Remainder} \rightarrow W(m+1)$						
Status Affected:	C, N, OV, Z						
Encoding:	1110	101U	www	sss	UUUU	UUUU	UUUU 0011
Description:	<p>Iterative, signed integer 32-bit by 32-bit divide to a 32-bit quotient and a 32-bit remainder. The sign of the remainder will be the same as that of the dividend. This instruction must be executed ten times to generate the correct quotient and remainder. This may only be achieved by executing a REPEAT with an iteration count of nine (i.e. 9+1 iterations in all) and the DIVSL instruction as its target. The REPEAT loop may be interrupted at any iteration boundary.</p> <p>C is modified as per the divide algorithm. Z is set if the remainder is clear. Z is cleared otherwise. N is set if the remainder is negative. N is cleared otherwise. OV is set if the divide will result in an overflow. OV is cleared otherwise. The quotient and remainder will be deterministic but meaningless.</p> <p>The 'w' bits select the source (dividend) register. The 's' bits select the source (divisor) register.</p> <p>Notes:</p> <ol style="list-style-type: none"> The divisor is tested for zero during the first iteration. An attempt to divide by zero will initiate an arithmetic error trap during the first cycle of DIVSL. Wn cannot share the same W-reg with Wm or $W(m+1)$. 						
I-Words:	1						
Cycles:	10						

DIVU		Unsigned Integer 16/16 and 32/16 Divide					
Syntax:	{label:}	DIVU.w	Wm,	Wn			
		DIVU.l					
Operands:		Wn ∈ [W0 ... W14], Wm ∈ [W0 ... W13]					
Operation:		DIVU.w (16/16); Wm[15:0] = Dividend, Wn[15:0] = Divisor: 16'b0 → Wm[31:16]; Wm / Wn → 16'b0, Wm[15:0]; Remainder → 16'b0, W(m+1)[15:0]					
		DIVU.l (32/16); Wm[31:0] = Dividend, Wn[15:0] = Divisor: Wm / Wn → 16'b0, Wm[15:0]; Remainder → 16'b0, W(m+1)[15:0]					
Status Affected:		C, N, OV, Z					
Encoding:		1110	100L	www	sss	UUUU	UUUU
						UUUU	0111
Description:		<p>Iterative, unsigned integer 32-bit (or 16-bit) by 16-bit divide to a 16-bit quotient and a 16-bit remainder, both of which are zero-extended to 32-bits prior to being written to Wm and W(m+1), respectively. The 16-bit by 16-bit divide also zero extends the dividend prior to executing the divide. This instruction must be executed six times to generate the correct quotient and remainder. This may only be achieved by executing a REPEAT with an iteration count of five (i.e. 5+1 iterations in all) and the DIVU instruction as its target. The REPEAT loop may be interrupted at any iteration boundary.</p> <p>C is modified as per the divide algorithm. Z is set if the remainder is clear. Z is cleared otherwise. N is always cleared. OV (DIVU.w) is always cleared because an overflow is not possible. OV (DIVU.l) is set if the divide will result in an overflow. OV is cleared otherwise.</p> <p>The 'L' bit selects 32-bit or 16-bit dividend size. The 'w' bits select the source (dividend) register. The 's' bits select the source (divisor) register.</p> <p>Notes:</p> <ol style="list-style-type: none"> 1. The divisor is tested for zero during the first iteration. An attempt to divide by zero will initiate an arithmetic error trap during the first cycle of DIVU.x 2. Wn cannot share the same W-reg with Wm or W(m+1). 					
I-Words:		1					
Cycles:		6					

DIVUL		Unsigned Integer 32/32 Divide					
Syntax:	{label:}	DIVUL	Wm,	Wn			
Operands:	Wn ∈ [W0 ... W14], Wm ∈ [W0 ... W13]						
Operation:	32/32; Wm = Dividend, Wn = Divisor: Wm / Wn → Wm; Remainder → W(m+1)						
Status Affected:	C, N, OV, Z						
Encoding:	1110	101U	www	sss	UUUU	UUUU	UUUU 0111
Description:	<p>Iterative, unsigned integer 32-bit by 32-bit divide to a 32-bit quotient and a 32-bit remainder. This instruction must be executed ten times to generate the correct quotient and remainder. This may only be achieved by executing a REPEAT with an iteration count of nine (i.e. 9+1 iterations in all) and the DIVUL instruction as its target. The REPEAT loop may be interrupted at any iteration boundary.</p> <p>C is modified as per the divide algorithm. Z is set if the remainder is clear. Z is cleared otherwise. N is always cleared. OV is always cleared because an overflow is not possible.</p> <p>The 'w' bits select the source (dividend) register. The 's' bits select the source (divisor) register.</p> <p>Notes:</p> <ol style="list-style-type: none"> 1. The divisor is tested for zero during the first iteration. An attempt to divide by zero will initiate an arithmetic error trap during the first cycle of DIVUL. 2. Wn cannot share the same W-reg with Wm or W(m+1). 						
I-Words:	1						
Cycles:	10						

DTB		Decrement, Test and Branch						
Syntax:	{label:}	DTB	Wn,	Label				
Operands:	Wn ∈ [W0 ... W14]; Label is resolved by the linker to a signed word offset (slit16)							
Operation:	Wn = Wn - 1; If (Wn != 0 [see text]) then { If slit16 = 1 then skip next (16-bit) instruction Else if (slit16 = 2 && next_op[31] = 1) then skip next (32-bit) instruction Else (PC+4) + 2*slit16 → PC } Else No branch							
Status Affected:	None							
Encoding:	1011	100U	ssss	nnnn	nnnn	nnnn	nnnn	UU01
Description:	Decrement Wn[31:0] and write result back to Wn (see note 2). Test Wn[31:0] after decrement and branch to target address if Wn[31:0] != 0. Do not branch when Wn[31:0] = 0. When utilized as a code block loop counter where DTB is located at the end of the loop, DTB will iterate the loop (i.e., branch) Wn times and will exit the loop with Wn = 0x0000_0000 (see note 2). If the branch condition is met, then the instruction will either skip the next 16-bit or 32-bit instruction, or it will branch to any size of instruction with a forward or backward range of 64KB. If the 2's complement byte offset value '2*slit16' (the PC offset) equals two, the conditional branch will execute as a conditional skip of one 16-bit instruction. This instruction will be speculatively executed as not skipped until such time that the branch decision can be determined. If the 2's complement byte offset value '2*slit16' (the PC offset) equals four and the instruction after the branch is a 32-bit opcode (see note), the conditional branch will execute as a conditional skip of that 32-bit instruction. This instruction will be speculatively executed as not skipped until such time that the branch decision can be determined. If requirements for a conditional skip are not met, the 2's complement byte offset value '2*slit16' is added to the PC to create a new PS word address. Since the PC will have incremented to fetch the next instruction, the new address will be (PC+4) + 2*slit16. Branch prediction is based on the direction of the branch. If the branch is backwards (negative), it will be predicted as taken. If the branch is forwards (positive), it will be predicted as not taken. The two instructions that follow the branch will then be speculatively executed in the predicted path until such time that the actual branch decision can be assessed. A correctly predicted branch will continue instruction execution in the same path unabated. An incorrectly predicted branch will abort the speculatively executed instructions and start execution from the correct path. The 'n' bits are a signed literal that specifies the number of PS words offset from (PC+4).							
	Notes:							
	1. Should the byte offset equal four and instruction after the branch is a 16-bit opcode, a branch will occur (over the next two 16-bit ops) if the condition is met. 2. Execution of DTB when Wn = 0 will result in a loop count of 2 ³¹ .							
I-Words:	1							
Cycles:	1 (2 or 3) Note: The taken branch target instruction fetch is not executed if an exception is pending, making effective instruction execution time one cycle.							

Example:1	Address	Label	Instruction	Comment
	0x804000		MOV.l #8, w6	;Update loop counter
	0x804004	_START_BUTTERFLY	MOV.l #1, W4	;Start of loop
		:		
	0x804008	-	SL.l w4, w6, w4	
	0x80400C	-	...	
	...	-	...	

Instruction Descriptions (C to DTB) (continued)

Example:1	Address	Label	Instruction	Comment
	0x804040	-	DTB W6, _START_BUTTERFLY	;Branch to 0x804004 if w6 != 0

4.6. Instruction Descriptions (E to MULUU)

ED	Subtract and Square to Accumulator (Partial Euclidean Distance)							
Syntax: {label}	ED{.w}	Wx,	Wy,	A	{,AWB}			
	ED.l	[Wx],	[Wy],	B				
		[Wx]+=kx	, [Wy]+=ky,					
		[Wx]-=kx	, [Wy]-=ky,					
		[Wx+=kx]	, [Wy+=ky],					
		[Wx-=kx]	, [Wy-=ky],					
		[Wx+W12]	, [Wy+W12],					
Operands:	Wx ∈ {W0 ... W14}; Wy ∈ {W0 ... W14}							
	Word mode: kx ∈ {-8, -6, -4, -2, 2, 4, 6, 8};							
	ky ∈ {-8, -6, -4, -2, 2, 4, 6, 8};							
	Long Word mode: kx ∈ {-16, -12, -8, -4, 4, 8, 12, 16};							
	ky ∈ {-16, -12, -8, -4, 4, 8, 12, 16};							
	AWB ∈ {W0, W1, W2, W3, W13, [W13++], [W15++] ⁴ }							
Operation:	$((Wx) - (Wy))^2 \rightarrow ACC(A \text{ or } B)$;							
	ACC(B or A) rounded \rightarrow AWB							
	When Indirect Pre/Post Modified Addressing:							
	$(Wx)+kx \rightarrow Wx$ or $(Wx)-kx \rightarrow Wx$;							
	$(Wy)+ky \rightarrow Wy$ or $(Wy)-ky \rightarrow Wy$;							
Status Affected:	OA,SA or OB,SB							
Encoding:	1101	10AL	www	ssss	IIII	iJJJ	jjaa	a011

Instruction Descriptions (E to MULUU) (continued)

ED Subtract and Square to Accumulator (Partial Euclidean Distance)

Description: Instruction to compute $(A-B)^2$ functions. Signed or unsigned (defined by CORCON.US) subtract then square of data concurrently read from Wx and Wy or fetched from X and Y address space (see note 3). The result is sign-extended or zero-extended to 72-bits then written to the specified accumulator. Fractional results are also scaled prior to the accumulator update to align the operand and accumulator (msw) fractional points. When indirect addressing is selected for either or both X and Y address space, the Wx and Wy registers provide the corresponding indirect addresses. The address modifier values are kx and ky, respectively, and represent the number of data bytes by which to modify the Effective Address.

The optional AWB specifies the direct or indirect (see note 4) store of the (32-bit) rounded fractional contents of the accumulator not targeted by the ED operation. Rounding mode is defined by CORCON.RND. Write data width is determined by selected instruction data size (see note 5). AWB is not intended for use when the DSP engine is operating in Integer mode.

Data read may be 16-bit or 32-bit values. All indirect address modification is scaled accordingly.

The 'L' bit selects word or long word operation.

The 'A' bit selects the accumulator for the result.

The 'I' bits select the Operation.X-Space Addressing mode.

The 'i' bits select the kx modification value.

The 'J' bits select the Operation.Y-Space Addressing mode.

The 'j' bits select the ky modification value.

The 's' bits select the Wx register

The 'w' bits select the Wy register.

The 'a' bits select the accumulator write-back destination and addressing mode.

Notes:

- Operates in Fractional or Integer Data mode as defined by CORCON.IF.
- Operands are always regarded as signed or unsigned based on the state of CORCON.US.
- Use of the same W-reg for both indirect source (X or Y) and AWB indirect destination is not permitted if the source is a pre- or post-modified Effective Address.
- Stack must remain long word aligned. Consequently, [W15++] AWB is only permitted for use with long word MAC-class instructions.

I-Words: 1

Cycles: 2

EDAC Subtract, Square and Accumulate (Euclidean Distance)

Syntax: EDAC{.w} Wx, Wy, A {,AWB}
{label}

EDAC.l [Wx], [Wy], B
 [Wx]+=kx, [Wy]+=ky,
 [Wx]-=kx, [Wy]-=ky,
 [Wx+=kx], [Wy+=ky],
 [Wx-=kx], [Wy-=ky],
 [Wx+W12], [Wy+W12],

Operands: Wx ∈ {W0 ... W14}; Wy ∈ {W0 ... W14}
 Word mode: kx ∈ {-8, -6, -4, -2, 2, 4, 6, 8};
 ky ∈ {-8, -6, -4, -2, 2, 4, 6, 8};
 Long Word mode: kx ∈ {-16, -12, -8, -4, 4, 8, 12, 16};
 ky ∈ {-16, -12, -8, -4, 4, 8, 12, 16};
 AWB ∈ {W0, W1, W2, W3, W13, [W13++], [W15++]⁴}

Instruction Descriptions (E to MULUU) (continued)

EDAC Subtract, Square and Accumulate (Euclidean Distance)

Operation: $ACC(A \text{ or } B) + ((Wx) - (Wy))^2 \rightarrow ACC(A \text{ or } B);$
 $(ACC(B \text{ or } A)) \text{ rounded} \rightarrow AWB$

When Indirect Pre/Post Modification Addressing:

$(Wx)+kx \rightarrow Wx$ or $(Wx)-kx \rightarrow Wx;$

$(Wy)+ky \rightarrow Wy$ or $(Wy)-ky \rightarrow Wy;$

Status Affected: OA,SA or OB,SB

Encoding: 1101 10AL wwwwww ssss IIIi iJJJ jjaa a111

Description: Instruction to compute $(A-B)^2$ functions. Signed or unsigned (defined by CORCON.US) subtract then square of data read from Wx and Wy or concurrently fetched from the X and Y address space. The result is sign-extended or zero-extended to 72-bits and then added to the specified accumulator. Fractional or integer operation (defined by CORCON.IF) will determine if the result is scaled or not prior to the accumulator update. Fractional operation will scale the result to align the operand and accumulator (msw) fractional points (see note 3). Integer operation will align the LSb of the result with the LSb of the accumulator. When indirect addressing is selected for either or both X and Y address space, the Wx and Wy registers provide the corresponding indirect addresses. The address modifier values are kx and ky, respectively, and represent the number of data words by which to modify the Effective Address.

The optional AWB specifies the direct or indirect (see note 4) store of the (32-bit) rounded fractional contents of the accumulator not targeted by the EDAC operation. Rounding mode is defined by CORCON.RND. Write data width is determined by selected instruction data size (see note 5). AWB is not intended for use when the DSP engine is operating in Integer mode.

Data read may be 16-bit or 32-bit values. All indirect address modification is scaled accordingly.

The 'L' bit selects word or long word operation.

The 'A' bit selects the accumulator for the result.

The 'I' bits select the Operation.X-Space Addressing mode.

The 'i' bits select the kx modification value.

The 'J' bits select the Operation.Y-Space Addressing mode.

The 'j' bits select the ky modification value.

The 's' bits select the Wx register.

The 'w' bits select the Wy register.

The 'a' bits select the accumulator write-back destination and addressing mode.

Notes:

- Operates in Fractional or Integer Data mode as defined by CORCON.IF.
- Operands are always regarded as signed or unsigned based on the state of CORCON.US.
- The LS portion of ACCx is unaffected when operating in Fractional mode with word sized data. Lower significance data that may be present from prior (32-bit data) operations is therefore preserved. Users not requiring this should clear ACCx during initialization.
- Use of the same W-reg for both indirect source (X or Y) and AWB indirect destination is not permitted if the source is a pre- or post-modified Effective Address.
- Stack must remain long word aligned. Consequently, [W15++] AWB is only permitted for use with long word MAC-class instructions.

I-Words: 1

Cycles: 2

EXCH Exchange Ws and Wd

Syntax: {label;} EXCH Wns, Wnd

Operands: Wns \in [W0 ... W15]; Wnd \in [W0 ... W15]

Operation: $(Wns) \leftrightarrow (Wnd)$

Status Affected: None

Encoding: 1000 001U dddd ssss UUUU UUUU UUUU 0100

Instruction Descriptions (E to MULUU) (continued)

EXCH Exchange Ws and Wd

Description: This instruction exchanges the contents of two Working registers and is a two cycle operation. In cycle one, Wnd is read and moved to Wns. In cycle two, Wns is read and moved to Wnd. The 's' bits select the Wns register. The 'd' bits select the Wnd register.

Notes:

1. Opcode shared with MOV (32-bit variant) using sub-opcode.
2. Long word operation is assumed.
3. Although operand order has no effect on final outcome, it could influence the detection of hazards because operands are read in different cycles.

I-Words: 1
Cycles: 2

FBCL Find First Bit Change from Left

Syntax: {label;} FBCL{.w} Ws, Wnd
FBCL.l [Ws],
[Ws++],
[Ws--],
[++Ws],
[--Ws],

Operands: Ws ∈ [W0 ... W15]; Wnd ∈ [W0 ... W14]

Operation: See description

Status Affected: C

Encoding: 1110 011L dddd ssss pppU UUUU UUUU 1011

Description: Finds the first occurrence of a one (for a positive signed value) or zero (for a negative signed value) starting from the next MSb after the Sign bit working towards the LSb of the word operand. The bit number is sign-extended to 32-bits and is written to the destination register. The next MSb after the Sign bit is assigned number zero. For a word operation, the LSb number is assigned -14 and a result of -15 (C=1) indicates that the bit was not found. For a long word operation, the LSb number is assigned -30 and a result of -31 (C=1) indicates that the bit was not found.

C is cleared for all non-zero results.

The 'L' bit selects word or long word operation.

The 's' bits select the source register.

The 'd' bits select the destination register.

The 'p' bits select the source addressing mode.

See and for modifier addressing information.

Note: This instruction only operates in Word and Long Word mode.

I-Words: 1
Cycles: 1

Example 1: FBCL W1, W9 ; Find 1st bit change from left in W1; and store result to W9

Before Instruction		After Instruction	
W1	55FF	W1	55FF
W9	FFFF	W9	0000
SR	0000	SR	0000

FF1L Find First One from Left

Syntax: {label;} FF1L{.w} Ws, Wnd
 FF1L.l [Ws],
 [Ws++],
 [Ws--],
 [++Ws],
 [--Ws],

Operands: Ws ∈ [W0 ... W15]; Wnd ∈ [W0 ... W14]

Operation: See description

Status Affected: C

Encoding: 1110 011L dddd ssss pppU UUUU UUUU 0011

Description: Finds the first occurrence of a one starting from the MSb working towards the LSb of the word operand. The bit number result is zero-extended to 32-bits and is written to the destination register. The MSb is assigned number one. For a word operation, the LSB number is assigned 16, and a result of zero (C=1) indicates that the bit was not found. For a long word operation, the LSB number is assigned 32 and a result of zero (C=1) indicates that the bit was not found.

C is cleared for all non-zero results.

The 'L' bit selects word or long word operation.

The 's' bits select the source register.

The 'd' bits select the destination register.

The 'p' bits select the source addressing mode.

Note: This instruction only operates in word and long word mode.

I-Words: 1

Cycles: 1

Example 1: FF1L W2, W5 ; Find the 1st one from the left in W2 ; and store result to W5

Before Instruction		After Instruction	
W2	000A	W2	000A
W5	BBBB	W5	000D
SR	0000	SR	0000

Example 2: FF1L [W2++], W5 ; Find the 1st one from the left in [W2] ; and store the result to W5 ; Post-increment W2

Before Instruction		After Instruction	
W2	2000	W2	2002
W5	BBBB	W5	0000
Data 2000	0000	Data 2000	0000
SR	0000	SR	0001 (C = 1)

FF1R Find First One from Right

Syntax: {label;} FF1R{.w} Ws, Wnd
 FF1R.l [Ws],
 [Ws++],
 [Ws--],
 [++Ws],
 [--Ws],

Operands: Ws ∈ [W0 ... W15]; Wnd ∈ [W0 ... W14]

Operation: See description

Status Affected: C

Encoding: 1110 011L dddd ssss pppU UUUU UUUU 0111

Description: Finds the first occurrence of a one starting from the LSb working towards the MSb of the word operand. The bit number result is zero-extended to 32-bits and is written to the destination register. The LSb is assigned number one. For a word operation, the MSb number is assigned 16, and a result of zero (C=1) indicates that the bit was not found. For a long word operation, the MSb number is assigned 32 and a result of zero (C=1) indicates that the bit was not found.

C is cleared for all non-zero results.

The 'L' bit selects word or long word operation.

The 's' bits select the source register.

The 'd' bits select the destination register.

The 'p' bits select the source addressing mode.

Note: This instruction only operates in word and long word mode.

I-Words: 1

Cycles: 1

Example 1: FF1R W1, W9 ; Find the 1st one from the right in W1 ; and store the result to W9

Before Instruction		After Instruction	
W1	000A	W1	000A
W9	BBBB	W9	0002
SR	0000	SR	0000

Example 2: FF1R [W1++], W9 ; Find the 1st one from the right in [W1] ; and store the result to W9 ; Post-increment W1

Before Instruction		After Instruction	
W1	2000	W1	2002
W9	BBBB	W9	0010
Data 2000	8000	Data 2000	8000
SR	0000	SR	0000

FLIM	Force (Signed) Data Range Limit							
Syntax:	{label:}	FLIM{.w}	Wb,	Ws,				
		FLIM.l		[Ws],				
				[Ws++],				
				[Ws--],				
				[++Ws],				
				[--Ws],				
Operands:	Ws ∈ [W0 ... W14]; Wb ∈ [W0 ... W13];							
Operation:	<pre> IF (Ws) > (Wb) THEN { (Wb) → (Ws); 0 → Z; 0 → N; 0 → OV } ELSE IF (Ws) < (Wb+1) THEN { (Wb+1) → Ws; 0 → Z; 1 → N; 0 → OV } ELSE { (Ws) → Ws4; 1 → Z; 0 → N; 0 → OV } </pre>							
Status Affected:	N, Z, OV							
Encoding:	1110	010L	UUUU	ssss	pppU	UUww	wwUU	0011

Instruction Descriptions (E to MULUU) (continued)

FLIM	Force (Signed) Data Range Limit
Description:	<p>Simultaneously compare any size of signed data value in Ws to a maximum signed limit value held in Wb and a minimum signed limit value held in Wb+1.</p> <p>For long word data size, if Ws[31:0] is greater than Wb[31:0], set Ws[31:0] to the limit value held in Wb[31:0]. For word data sizes, if Ws[15:0] is greater than Wb[15:0], set Ws[15:0] to the limit value held in Wb[15:0] (Ws[31:16] is ignored). The Z, N and OV status bits are updated such that a subsequent BGT instruction will take a branch.</p> <p>For long word data size, if Ws[31:0] is less than Wb+1[31:0], set Ws[31:0] to the limit value held in Wb+1[31:0]. For word data sizes, if Ws[15:0] is less than Wb+1[15:0], set Ws[15:0] to the limit value held in Wb+1[15:0] (Ws[31:16] is ignored). The Z, N and OV status bits are updated such that a subsequent BLT instruction will take a branch.</p> <p>If Ws[31:0] is less than or equal to the maximum limit value in Wb[31:0], and greater than or equal to the minimum limit value in Wb+1[31:0] (for long word sized data), or Ws[15:0] is less than or equal to the maximum limit value in Wb[15:0] and greater than or equal to the minimum limit value in Wb+1[15:0] (for word sized data), neither data limit is applied such that the contents of Ws will not change (for the given data size). The Z status bit is set such that a subsequent BZ instruction will take a branch (OV and N status are both cleared).</p> <p>For word sized register direct operations, Ws is always 0 extended to 32-bits (even if neither of the data limits are applied)⁴.</p> <p>Note that the instruction always executes the maximum compare first. Should Ws be less than the maximum, it will then execute the minimum compare, and if Ws is found to be not less than the minimum, Ws will remain unchanged.</p> <p>Furthermore, should the (maximum) limit value Wb be inadvertently set to less than or equal to the (minimum) limit value Wb+1, the same compare sequence will still be executed. This condition is not detected.</p> <p>The OV status bit is always cleared by this instruction.</p> <p>The 's' bits select the source (data value) register.</p> <p>The 'w' bits select the base (data limit) register.</p> <p>The 'p' bits select the source addressing mode.</p> <p>Notes:</p> <ol style="list-style-type: none"> 1. Although the instruction assumes signed values for all operands, both upper and lower limit values may be of the same sign. 2. The status bits are set based upon the data compare result. 3. Word data FLIM{.w} writes to Ws are zero extended to 32-bits. 4. Zero extension to 32-bits is consistent with any register direct word write. However, the potential for a RAW hazard from the Ws write therefore always exists, even if the limit is not exceeded.
I-Words:	1
Cycles:	1

FLIM		Force (Signed) Data Range Limit with Limit Excess Result							
Syntax:	{label:}	FLIM{.w}{v} Wb,	Ws,	Wd					
		FLIM.l{v}	[Ws],	[Wd]					
			[Ws++],	[Wd++]					
			[Ws--],	[Wd--]					
			[++Ws],	[++Wd]					
			[--Ws],	[--Wd]					
Operands:		Ws ∈ [W0 ... W14]; Wb ∈ [W0 ... W13]; Wnd ∈ [W0 ... W14]							
Operation:		<pre> IF (Ws) > (Wb) THEN (IF FLIM.v THEN (Ws) - (Wb) → Wnd ELSE +1 → Wnd; (Wb) → (Ws); 0 → Z; 0 → N; 0 → OV;) ELSE IF (Ws) < (Wb+1) THEN (IF FLIM.v THEN (Ws) - (Wb+1) → Wnd ELSE -1 → Wnd; (Wb+1) → (Ws); 0 → Z; 1 → N; 0 → OV;) ELSE (0 → Wnd; (Ws) → Ws⁴; 1 → Z; 0 → N; 0 → OV;) </pre>							
Status Affected:		N, Z, OV							
Encoding:		1110	010L	dddd	ssss	ppdq	qqww	wwUV	0111

Instruction Descriptions (E to MULUU) (continued)

FLIM	Force (Signed) Data Range Limit with Limit Excess Result
Description:	<p>Simultaneously compare any size of signed data value in Ws to a maximum signed limit value held in Wb and a minimum signed limit value held in $Wb+1$. Write a limit excess value into Wnd. For long word data size, if $Ws[31:0]$ is greater than $Wb[31:0]$, set $Ws[31:0]$ to the limit value held in $Wb[31:0]$. For word data sizes, if $Ws[15:0]$ is greater than $Wb[15:0]$, set $Ws[15:0]$ to the limit value held in $Wb[15:0]$ ($Ws[31:16]$ is ignored).</p> <p>In all cases, write the (signed) value by which the limit is exceeded to $Wnd[31:0]$ (FLIM.v, where opcode bit field $V = 1$) or set Wnd to +1 (FLIM, where opcode bit field $V = 0$). Whenever Ws is greater than Wb, Wnd will always be a positive value. The Z, N and OV status bits are updated such that a subsequent BGT instruction will take a branch.</p> <p>For long word data size, if $Ws[31:0]$ is less than $Wb+1[31:0]$, set $Ws[31:0]$ to the limit value held in $Wb+1[31:0]$. For word data sizes, if $Ws[15:0]$ is less than $Wb+1[15:0]$, set $Ws[15:0]$ to the limit value held in $Wb+1[15:0]$ ($Ws[31:16]$ is ignored). In all cases, write the (signed) value by which the limit is exceeded to $Wnd[31:0]$ (FLIM.v, where opcode bit field $V = 1$) or set Wnd to +1 (FLIM, where opcode bit field $V = 0$). Whenever Ws is less than $Wb+1$, Wnd will always be a negative value. The Z, N and OV status bits are updated such that a subsequent BLT instruction will take a branch.</p> <p>If $Ws[31:0]$ is less than or equal to the maximum limit value in $Wb[31:0]$ and greater than or equal to the minimum limit value in $Wb+1[31:0]$ (for long word sized data), or $Ws[15:0]$ is less than or equal to the maximum limit value in $Wb[15:0]$ and greater than or equal to the minimum limit value in $Wb+1[15:0]$ (for word sized data), neither data limit is applied such that contents of Ws will not change (for the given data size). The Z status bit is set such that a subsequent BZ instruction will take a branch (OV and N status are both cleared).</p> <p>For word sized register direct operations, Ws is always zero extended to 32-bits (even if neither of the data limits are applied)⁴.</p> <p>Note that the instruction always executes the maximum compare first. Should Ws be less than the maximum, it will then execute the minimum compare, and if Ws is found to be not less than the minimum, Ws will remain unchanged.</p> <p>Furthermore, should the (maximum) limit value Wb be inadvertently set to less than or equal to the (minimum) limit value $Wb+1$, the same compare sequence will still be executed. This condition is not detected.</p> <p>The OV status bit is always cleared by this instruction.</p> <p>The 's' bits select the source (data value) register.</p> <p>The 'w' bits select the base (data limit) register.</p> <p>The 'd' bits select the destination (limit test result) register.</p> <p>The 'p' bits select the source addressing mode.</p> <p>The 'q' bits select the destination addressing mode.</p> <p>The 'V' bit selects the result format for Wnd.</p> <p>See for modifier addressing information.</p> <p>Notes:</p> <ol style="list-style-type: none"> 1. Although the instruction assumes signed values for all operands, both upper and lower limit values may be of the same sign. 2. The status bits are set based upon the value loaded into Wnd. 3. Word data FLIM{.w} writes to Ws (and FLIM{.w}v writes to Wnd) are zero extended to 32-bits. 4. Zero extension to 32-bits is consistent with any register direct word write. However, the potential for a RAW hazard from the Ws write therefore always exists, even if the limit is not exceeded. 5. Ws and Wd cannot be the same register.
I-Words:	1
Cycles:	2

GOTO		Unconditional Jump	
Syntax:	{label;} GOTO lit24		
Operands:	lit24 ∈ [0 ... 16MB]		
Operation:	lit24 → PC[23:0], NOP → Instruction Register.		
Status Affected:	None		
Encoding:	1101 101n nnnn nnnn nnnn nnnn nnnn nn10		
Description:	<p>Unconditional jump to any address within (for latency) one cycle's memory space. The 24-bit value 'lit24' is loaded into the PC. A jump to either a 32-bit or 16-bit instruction is permitted. The 'n' bits form the target address.</p> <p>Note: The (byte) PC address is always either word or long word aligned. The opcode does not store the LSB because it is always 1'b0.</p>		
I-Words:	1		
Cycles:	1		

Example:1	Address	Label	Instruction	Comment
	0x804000	-	GOTO _CHECK_FAIL	; Jumps to address 0x805000(_CHECK_FAIL)
	...			
	0x805000	_CHECK_FAIL:	MOV.I SR, W6 CP w6, w7	; Random code

GOTO		Unconditional Indirect Jump						
Syntax:	{label;} GOTO Wns							
Operands:	Wns ∈ [W0 ... W14]							
Operation:	(Wns) → PC[23:0]; NOP → Instruction Register.							
Status Affected:	None							
Encoding:	1101	011U	UUUU	ssss	UUUU	UUUU	UUUU	1010
Description:	Unconditional indirect jump to any address within executable memory address space. The Wns[23:0] is loaded into PC[23:0]. Wns must therefore contain a PS byte address. The value of Wns[0] is ignored and PC[0] is always set to 1'b0. GOTO is a two-cycle instruction. The 's' bits select the source register. If Wns[31:24] != 8'h00, an address error trap will be initiated.							
I-Words:	1							
Cycles:	2							
	Note: The goto target instruction fetch is not executed if an exception is pending, making effective instruction execution time one cycle.							

Example:1	Address	Label	Instruction	Comment
	0x804000	-	GOTO _CHECK_FAIL	; Jumps to address 0x805000(_CHECK_FAIL)
	...			
	0x805000	_CHECK_FAIL:	MOV.I SR, W6 CP w6, w7	; Random code

INC		Increment f					
Syntax:	{label:}	INC.b	f	{Wnd}	{WREG}		
		INC.bz					
		INC{,w}					
		INC.l					
Operands:	f ∈ [0 ... 64KB]; Wnd ∈ [W0 ... W14]						
Operation:	(f) + 1 → destination designated by D						
Status Affected:	C, N, OV, Z						
Encoding:	1101	010L	dddd	ffff	ffff	ffff	BD01
Description:	<p>Add one to the contents of the file register and place the result in the destination designated by D. If the optional Wnd is specified, D=0 and store result in Wnd; otherwise, D=1 and store result in the file register.</p> <p>The 'L' and 'B' bits select operation data width.</p> <p>The 'D' bit selects the destination.</p> <p>The 'f' bits select the address of the file register.</p> <p>The 'd' bits select the Working register.</p>						
I-Words:	1						
Cycles:	1						

Example 1: `INC.B 0x1000 ; Increment 0x1000 (Byte mode)`

Before Instruction		After Instruction	
Data 1000	8FFF	Data 1000	8F00
SR	0000	SR	0101 (DC, C = 1)

Example 2: `INC 0x1000, WREG ; Increment 0x1000 and store to WREG ; (Word mode)`

Before Instruction		After Instruction	
WREG	ABCD	WREG	9000
Data 1000	8FFF	Data 1000	8FFF
SR	0000	SR	0108 (DC, N = 1)

INC2		Increment f by 2						
Syntax:	{label:}	INC2.b	f	{Wnd}	{WREG}			
		INC2.bz						
		INC2{.w}						
		INC2.l						
Operands:	f ∈ [0 ... 64KB]; Wnd ∈ [W0 ... W14]							
Operation:	(f) + 2 → destination designated by D							
Status Affected:	C, N, OV, Z							
Encoding:	1101	110L	dddd	ffff	ffff	ffff	ffff	BD01
Description:	Add two to the contents of the file register and place the result in the destination designated by D. If the optional Wnd is specified, D=0 and store result in Wnd; otherwise, D=1 and store result in the file register. The 'L' and 'B' bits select operation data width. The 'D' bit selects the destination. The 'f' bits select the address of the file register. The 'd' bits select the Working register.							
I-Words:	1							
Cycles:	1							

Example 1: `INC2.B 0x1000 ; Increment 0x1000 by 2 ; (Byte mode)`

Before Instruction		After Instruction	
Data 1000	8FFF	Data 1000	8F01
SR	0000	SR	0101 (DC, C = 1)

Example 2: `INC2 0x1000, WREG ; Increment 0x1000 by 2 and store to WREG ; (Word mode)`

Before Instruction		After Instruction	
WREG	ABCD	WREG	9001
Data 1000	8FFF	Data 1000	8FFF
SR	0000	SR	0108 (DC, N = 1)

IOR		Inclusive OR Wb and Ws			
Syntax:	{label:}	IOR.b	Wb,	Ws,	Wd
		IOR.bz		[Ws],	[Wd]
		IOR{.w}		[Ws++],	[Wd++]
		IOR.l		[Ws--],	[Wd--]
				[++Ws],	[++Wd]
				[--Ws],	[--Wd]
				SR	SR
Operands:	Wb ∈ [W0 ... W14]; Ws ∈ [W0 ... W15]; Wd ∈ [W0 ... W15]				
Operation:	(Wb).IOR.(Ws) → Wd				
Status Affected:	N, Z				
Encoding:	S110	101L	dddd	ssss	pppq qqww wwUU BU00
Description:	<p>Compute the Inclusive OR of the contents of the source register Ws and the contents of the base register Wb and place the result in the destination register Wd. The 'S' bit selects instruction size. The 'L' and 'B' bits select operation data width. The 's' bits select the source register. The 'w' bits select the base register. The 'd' bits select the destination register. The 'p' bits select the source addressing mode. The 'q' bits select the destination addressing mode.</p> <p>Notes:</p> <ol style="list-style-type: none"> When the SR is selected, SR data write will take priority over any SR update resulting from the IOR operation. .bz data size/mode is disallowed when writing to the SR. 				
I-Words:	1 or 0.5				
Cycles:	1				

Example 1: IOR.B W1, [W5++], [W9++] ; IOR W1 and [W5] (Byte mode) ; Store result to [W9] ; Post-increment W5 and W9

Before Instruction		After Instruction	
W1	AAAA	W1	AAAA
W5	2000	W5	2001
W9	2400	W9	2401
Data 2000	1155	Data 2000	1155
Data 2400	0000	Data 2400	00FF
SR	0000	SR	0008 (N = 1)

Example 2: IOR W1, W5, W9 ; IOR W1 and W5 (Word mode) ; Store the result to W9

Before Instruction		After Instruction	
W1	AAAA	W1	AAAA
W5	5555	W5	5555
W9	A34D	W9	FFFF
SR	0000	SR	0008 (N = 1)

IOR		Inclusive OR Wb and Short Literal			
Syntax:	{label:}	IOR.b	Ws,	lit7,	Wd
		IOR.bz	[Ws],		[Wd]
		IOR{.w}	[Ws++],		[Wd++]
		IOR.l	[Ws--],		[Wd--]
			[++Ws],		[++Wd]
			[--Ws],		[--Wd]
			SR		SR
Operands:	Ws ∈ [W0 ... W15]; lit7 ∈ [0 ... 127]; Wd ∈ [W0 ... W15]				
Operation:	(Ws).IOR.lit7 → Wd Note: The literal is zero-extended to the selected data size of the operation				
Status Affected:	N, Z				
Encoding:	1110	101L	dddd	ssss	pppq qqkk kkkk Bk10
Description:	<p>Compute the Inclusive OR of the contents of the source register Ws and the zero-extended literal operand and place the result in the destination register Wd. The 'L' and 'B' bits select operation data width. The 'k' bits provide the literal operand (MSb in op[2]). The 's' bits select the source register. The 'd' bits select the destination register. The 'p' bits select the source addressing mode. The 'q' bits select the destination addressing mode. See and for modifier addressing information.</p> <p>Notes:</p> <ol style="list-style-type: none"> When the SR is selected, SR data write will take priority over any SR update resulting from the AND operation. .bz data size/mode is disallowed when writing to the SR. 				
I-Words:	1				
Cycles:	1				

Example 1: IOR.B W1, #0x5, [W9++] ; IOR W1 and 0x5 (Byte mode) ; Store to [W9] ; Post-increment W9

	Before Instruction	After Instruction
W1	AAAA	W1 AAAA
W9	2000	W9 2001
Data 2000	0000	Data 2000 00AF
SR	0000	SR 0008 (N = 1)

Example 2: IOR W1, #0x0, W9 ; IOR W1 with 0x0 (Word mode) ; Store to W9

	Before Instruction	After Instruction
W1	0000	W1 0000
W9	A34D	W9 0000
SR	0000	SR 0002 (Z = 1)

IOR		Inclusive OR Literal and Wn						
Syntax:	{label:}	IOR.b	lit16,	Wn				
		IOR.bz		SR				
		IOR{.w}						
		IOR.l						
Operands:		lit16 ∈ [0 ... 65535]; Wn ∈ [W0 ... W14]; Status Register (SR)						
Operation:		(Wn) .IOR. lit16 ³ → Wn or (SR) .IOR. lit16 → SR						
Status Affected:		N, Z						
Encoding:		1100	101L	ssss	kkkk	kkkk	kkkk	BT10
Description:		<p>Compute the Inclusive OR of the literal operand and the contents of the Working register Wn or SR and place the result in the Working register Wn or SR. The 'L' and 'B' bits select operation data width. The 's' bits select the Working register. The 'k' bits specify the literal operand. The 'T' bit selects between Ws (T = 0) and SR (T = 1) target registers.</p> <p>Notes:</p> <ol style="list-style-type: none"> 1. When the SR is selected, SR data write will take priority over any SR update resulting from the AND operation. 2. .bz data size/mode is disallowed when writing to the SR. 3. The literal is zero-extended to 32-bits for long word operations. 						
I-Words:		1						
Cycles:		1						

Example 1:	IOR.B #0xAA, W9 ; IOR 0xAA to W9 ; (Byte mode)						
	Before Instruction			After Instruction			
	W9	1234		W9	12BE		
	SR	0000		SR	0008	(N = 1)	

Example 2:	IOR #0x2AA, W4 ; IOR 0x2AA to W4 ; (Word mode)						
	Before Instruction			After Instruction			
	W4	A34D		W4	A3EF		
	SR	0000		SR	0008	(N = 1)	

IOR		Inclusive OR f and Wn							
Syntax:	{label:}	IOR.b	f	,Wn	{WREG}				
		IOR.bz							
		IOR{.w}							
		IOR.l							
Operands:		f ∈ [0 ... 64KB]; Wn ∈ [W0 ... W14]							
Operation:		(f).IOR.(Wn) → destination designated by D							
Status Affected:		N, Z							
Encoding:		1110	101L	ssss	ffff	ffff	ffff	ffff	BD01
Description:		<p>Compute the Inclusive OR of the contents of the Working register and the contents of the file register and place the result in the destination designated by D. If the optional Wn is specified, D=0 and store result in Wn; otherwise, D=1 and store result in the file register.</p> <p>The 'L' and 'B' bits select operation data width.</p> <p>The 'D' bit selects the destination.</p> <p>The 'f' bits select the address of the file register.</p> <p>The 's' bits select the Working register.</p>							
I-Words:		1							
Cycles:		1							

LAC		Load Accumulator							
Syntax:	{label:}	LAC{.w}	Ws,	{ Slit6, }	A				
		LAC.l	[Ws],		B				
			[Ws++]						
			[Ws--]						
			[-Ws],						
			[++Ws],						
			[Ws+Wb],						
Operands:		Ws ∈ [W0 ... W15]; Wb ∈ [W0 ... W15]; Slit6 ∈ [-32 ... +31]							
Operation:		<u>For Word operation:</u> 8{Ws[15]}, Ws[15:0], 48'h000000000000 → ACC[71:0] Shift _{Slit6} (ACC) → ACC <u>For Long Word operation:</u> 8{Ws[31]}, Ws[31:0], 32'h00000000 → ACC[71:0] Shift _{Slit6} (ACC) → ACC							
Status Affected:		OA, SA or OB, SB							
Encoding:		1100	00AL	www	sss	pppU	UUkk	kkkk	0011
Description:		Read the contents of the Effective Address. Place the data read into the target accumulator, then optionally shift the entire accumulator. For a word operation (LAC{.w}), the value contained at the Effective Address is assumed to be Q1.15 signed fractional data and is written into ACCx[63:48]. ACCx[47:0] is set to all 0's, and ACCx[63:0] is automatically sign-extended (through bit 71). The accumulator is then arithmetically shifted by the value held in slit6. For a long word operation (LAC.l), the value contained at the Effective Address is assumed to be Q1.31 signed fractional data and is written into ACCx[63:32]. ACCx[31:0] is set to all 0's, and ACCx[63:0] is automatically sign-extended (through bit 71). The accumulator is then arithmetically shifted by the value held in slit6. The 'L' bit selects word or long word operation. The 'A' bits specify the destination accumulator. The 's' bits specify the source register Wns. The 'p' bits select the source addressing mode. The 'w' bits specify the offset register Wb. The 'k' bits encode the optional operand Slit6 which determines the amount of the accumulator shift; if the operand Slit6 is absent, the literal bit field is set to all 0's. Note: Positive values of operand Slit6 represent arithmetic shift right. Negative values of operand Slit6 represent shift left.							
I-Words:		1							
Cycles:		1							

Example 1: LAC [W4++], #-3, B ; Load ACCB with [W4] << 3 ; Contents of [W4] do not change ; Post increment W4 ; Assume saturation disabled ; (SATB = 0)

	Before Instruction		After Instruction	
W4	2000	W4	2002	
ACCB	00 1525 ABCD 2512 1922	ACCB	FF 9108 0000 0000 0000	
Data 2000	1221	Data 2000	1221	
SR	0000	SR	4800 (OB, OAB = 1)	

Example 2: LAC [--W2], #7, A ; Pre-decrement W2 ; Load ACCA with [W2] >> 7 ; Contents of [W2] do not change ; Assume saturation disabled ; (SATA = 0)

	Before Instruction	After Instruction	
W2	4002	W2	4000

Instruction Descriptions (E to MULUU) (continued)

Example 2: LAC [--W2], #7, A ; Pre-decrement W2 ; Load ACCA with [W2] >> 7 ; Contents of [W2] do not change ; Assume saturation disabled ; (SATA = 0)

ACCA	00 1525 ABCD 2512	ACCA	FF FF22 1000 0000
	1922		0000
Data 4000	9108	Data 4000	9108
Data 4002	1221	Data 4002	1221
SR	0000	SR	0000

LLAC		Load Lower Accumulator			
Syntax:	{label:}	LLAC.l	Ws,	{ Slit6, }	A
			[Ws],		B
			[Ws++]		
			[Ws--]		
			[-Ws],		
			[++Ws],		
			[Ws+Wb],		
Operands:	Ws ∈ [W0 ... W15]; Wb ∈ [W0 ... W15]; Slit6 ∈ [-32 ... +31]				
Operation:	Ws[31:0] → ACC[31:0] Shift _{Slit6} (ACC) → ACC				
Status Affected:	OA, SA or OB, SB				
Encoding:	1100	00A1	www	sss	pppU UUkk kkkk 0111
Description:	<p>Read the contents of the Effective Address. Place the data read into the lower 32-bits of the target accumulator (ACCx[31:0]), then optionally arithmetically shift the entire accumulator. The 'A' bits specify the destination accumulator.</p> <p>The 's' bits specify the source register Wns.</p> <p>The 'p' bits select the source addressing mode.</p> <p>The 'w' bits specify the offset register Wb.</p> <p>The 'k' bits encode the optional operand Slit6 which determines the amount of the accumulator shift; if the operand Slit6 is absent, the literal bit field is set to all 0's.</p> <p>Note: Positive values of operand Slit6 represent arithmetic shift right. Negative values of operand Slit6 represent shift left.</p>				
I-Words:	1				
Cycles:	1				

Example:1 LLAC A, #4, w8 ; Load ACCAL from w8 ;Right shift value of ACCA by 4

	Before execution	After execution
ACCA	0x00_1022_2EE1_5633_9078	ACCA 0xFF_F102_22EE_1123_4567
w8	0x12345678	w8 0x12345678

LNK		Allocate Stack Frame						
Syntax:	{label:}	LNK	lit16					
Operands:	lit16 ∈ [0 ... 65535]							
Operation:	(W14) → (TOS) (W15) + 4 → W15 (W15) → W14; (W15) + lit16 → W15							
Status Affected:	None							
Encoding:	1101	010U	UUUU	kkkk	kkkk	kkkk	kkkk	1010
Description:	This instruction allocates a stack frame of size lit16 bytes (though always long word aligned) and adjusts the Stack Pointer and Frame Pointer. The 'k' bits specify the size of the stack frame in bytes.							
	Note:							
	1. This instruction operates with long word aligned operands only. The LS 2-bits of the literal encoding are therefore always set to 2'b00.							
I-Words:	1							
Cycles:	1							

Example:1	LNK	#8	;Allocate stack frame			
-----------	-----	----	-----------------------	--	--	--

Before execution		After execution	
W14	0x1234	W14	0x5004
W15	0x5000	W15	0x500C
Data @0x5000	0x0000	Data @0x5000	0x1234

LNK	Allocate Stack Frame (short)			
Syntax:	{label:}	LNK	lit7	
Operands:	lit7 ∈ [0 ... 127]			
Operation:	(W14) → (TOS) (W15) + 4 → W15 (W15) → W14; (W15) + lit5, 2'b00 → W15			
Status Affected:	None			
Encoding:	0111	001k	kkkk	1110
Description:	This instruction allocates a stack frame of size lit7 bytes and adjusts the Stack Pointer and Frame Pointer. The 'k' bits specify the size of the stack frame (in long words).			
	Note:			
	1. This instruction operates with long word aligned operands only. The LS 2-bits of the frame size are therefore assumed to be always set to 2'b00 (i.e., such that only 5-bits of the literal need be encoded within the opcode).			
I-Words:	0.5			
Cycles:	1			

LSR		Logical Shift Right by 1							
Syntax:	{label:}	LSR.b	Ws,	Wd					
		LSR.bz	[Ws],	[Wd]					
		LSR{.w}	[Ws++],	[Wd++]					
		LSR.l	[Ws--],	[Wd--]					
			[++Ws],	[++Wd]					
			--Ws],	--Wd]					
Operands:		Ws ∈ [W0 ... W15]; Wd ∈ [W0 ... W15]							
Operation:		For long word operation: 0 → Wd[31], (Ws[31:1]) → Wd[30:0], (Ws[0]) → C							
		For word operation: 0 → Wd[15], (Ws[15:1]) → Wd[14:0], (Ws[0]) → C							
		For byte operation: 0 → Wd[7], (Ws[7:1]) → Wd[6:0], (Ws[0]) → C							
		0		C					
Status Affected:		C,N,Z							
Encoding:		S010	101L	dddd	ssss	pppq	qqUU	UUUU	B000
Description:		<p>Logical shift right the contents of the source register Ws by one bit, placing the result in the destination register Wd.</p> <p>Destination register direct Extended Byte or Word mode will zero-extend the result to 32-bits, then write to Wd.</p> <p>The 'S' bit selects instruction size.</p> <p>The 'L' and 'B' bits select operation data width.</p> <p>The 's' bits select the source register.</p> <p>The 'd' bits select the destination register.</p> <p>The 'p' bits select the source addressing mode.</p> <p>The 'q' bits select the destination addressing mode.</p> <p>Note:</p> <ol style="list-style-type: none"> The N flag can only be set if the MSb of Ws = 1 with a shift value of zero. 							
I-Words:		1 or 0.5							
Cycles:		1							

LSR		Logical Shift Right f			
Syntax:	{label:}	LSR.b	f	{Wnd}	{WREG}
		LSR.bz			
		LSR{.w}			
		LSR.l			
Operands:	f ∈ [0 ...64KB]; Wnd ∈ [W0 ... W14]				
Operation:	<p><u>For byte operation:</u> 0 → Dest[7:1], (f[7:1]) → Dest[6:0], (f[0]) → C</p> <p><u>For word operation:</u> 0 → Dest[15], (f[15:1]) → Dest[14:0], (f[0]) → C</p> <p><u>For long word operation:</u> 0 → Dest[31], (f[31:1]) → Dest[30:0], (f[0]) → C</p>				
Status Affected:	C, N, Z				
Encoding:	1010	001L	dddd	ffff	ffff ffff ffff BD01
Description:	<p>Shift the contents of the file register f one bit to the right and place the result in the destination designated by D. If the optional Wnd is specified, D=0 and store result in Wnd; otherwise, D=1 and store result in the file register. The carry flag bit is set if the LSB of the file register is '1'. The N flag is always cleared.</p> <p>The 'L' and 'B' bits select operation data width.</p> <p>The 'D' bit selects the destination.</p> <p>The 'f' bits select the address of the file register.</p> <p>The 'd' bits select the Working register.</p>				
I-Words:	1				
Cycles:	1				

Example 1: LSR.B 0x600 ; Logically shift right (0x600) by one ; (Byte mode)

Before Instruction		After Instruction	
Data 600	55FF	Data 600	557F
SR	0000	SR	0001 (C = 1)

Example 2: LSR 0x600, WREG ; Logically shift right (0x600) by one ; Store to WREG ; (Word mode)

Before Instruction		After Instruction	
Data 600	55FF	Data 600	55FF
WREG	0000	WREG	2AFF
SR	0000	SR	0001 (C = 1)

LSR		Logical Shift Right by Short Literal			
Syntax:	{label:}	LSR{.w}	Ws,	lit5,	Wd
		LSR.l	[Ws],		[Wd]
			[Ws++],		[Wd++]
			[Ws--],		[Wd--]
			[++Ws],		[--Wd]
			[--Ws],		[++Wd]
Operands:	Ws ∈ [W0 ... W15]; lit5 ∈ [0...32]; Wd ∈ [W0 ... W14]				
Operation:	lit5[4:0] → Shift_Val 1'b0 → Right shift input (logical shift) For long word operation: Ws[31:0], 32'b0 → Shift_In[63:0] Logical shift right Shift_In[63:0] by Shift_Val → Shift_Out[63:0] Shift_Out[63:32] → Wd For word operation: 16'b0, Ws[15:0], 32'b0 → Shift_In[63:0] Logical shift right Shift_In[63:0] by Shift_Val → Shift_Out[63:0] Shift_Out[47:32] → Wd[15:0]				
Status Affected:	N,Z				
Encoding:	s010	001k	kkkk	dddd	pppq qqss ssUU L000
Description:	<p>Logical shift right the contents of the source register Ws by lit5 bits (up to 31 positions), placing the result in the destination Wd.</p> <p>The N flag is always cleared unless the shift value is zero (see note 1).</p> <p>This instruction will generate the correct result for any shift value in lit5 (a word operation shift value > 15, Wd[15:0]=0x0000).</p> <p>Register Direct Word mode will zero-extend the result to 32-bits, then write to Wd.</p> <p>The 'S' bit selects instruction size.</p> <p>The 'L' bit selects word or long word operation.</p> <p>The 's' bits select the source register.</p> <p>The 'd' bits select the destination register.</p> <p>The 'p' bits select the source addressing mode.</p> <p>The 'q' bits select the destination addressing mode.</p> <p>The 'k' bits provide the literal operand.</p> <p>Notes:</p> <ol style="list-style-type: none"> The N flag can only be set if the MSb of Ws = 1 with a shift value of zero. This instruction only operates in Word or Long Word mode. 				
I-Words:	1 or 0.5				
Cycles:	1				

Example 1: LSR W4, #14, W5 ; LSR W4 by 14 ; Store result to W5

Before Instruction		After Instruction	
W4	C800	W4	C800
W5	1200	W5	0003
SR	0000	SR	0000

Example 2: LSR W4, #1, W5 ; LSR W4 by 1 ; Store result to W5

Before Instruction		After Instruction	
W4	0505	W4	0505

Instruction Descriptions (E to MULUU) (continued)

Example 2:	LSR W4, #1, W5	; LSR W4 by 1	; Store result to W5
	W5	F000	W5 0282
	SR	0000	SR 0000

LSR		Logical Shift Right by Wb							
Syntax:	{label:}	LSR.b	Ws,	Wb,	Wd				
		LSR.bz	[Ws],		[Wd]				
		LSR{.w}	[Ws++],		[Wd++]				
		LSR.l	[Ws--],		[Wd--]				
			[++Ws],		[++Wd]				
			[--Ws],		[--Wd]				
Operands:		Ws ∈ [W0 ... W15]; Wb ∈ [W0 ... W15]; Wd ∈ [W0 ... W15]							
Operation:		Wb[15:0] → Shift_Val For long word operation: Ws[31:0], 32'b0 → Shift_In[63:0] Logical shift right Shift_In[63:0] by Shift_Val → Shift_Out[63:0] Shift_Out[63:32] → Wd For word operation: 16'b0, Ws[15:0], 32'b0 → Shift_In[63:0] Logical shift right Shift_In[63:0] by Shift_Val → Shift_Out[63:0] Shift_Out[47:32] → Wd[15:0] For byte operation: 24'b0, Ws[7:0], 32'b0 → Shift_In[63:0] Logical shift right Shift_In[63:0] by Shift_Val → Shift_Out[63:0] Shift_Out[39:32] → Wd[7:0]							
Status Affected:		N,Z							
Encoding:		1010	101L	www	ddd	pppq	qqss	ssUU	B100
Description:		Logical shift right the contents of the source register Ws by Wb bits, placing the result in the destination register Wd. When used in isolation, this instruction will generate the correct result for any shift value in Wb[15:0]: <ul style="list-style-type: none"> • For a byte operation shift value > 7, Wd[7:0]=0x00 • For a word operation shift value > 15, Wd[15:0]=0x0000 • For a long word operation shift value > 31, Wd=0x00000000 When used in conjunction with ASRMW and/or LSRMW instructions for multi-precision multi-bit shift operations, this instruction will not generate a correct result for any shift value greater than 32. Any data held in Wb[31:16] will have no effect. The N flag is always cleared unless the shift value is 0 (see note 1). Destination register direct Extended Byte or Word mode will zero-extend the result to 32-bits, then write to Wd. The 'L' and 'B' bits select operation data width. The 's' bits select the source register. The 'w' bits select the base (shift count) register. The 'd' bits select the destination register. The 'p' bits select the source addressing mode. The 'q' bits select the destination addressing mode. Note: <ol style="list-style-type: none"> 1. The N flag can only be set if the MSb of Ws = 1 with a shift value of zero. 							
I-Words:		1							
Cycles:		1							

LSRM	Logical Shift Right Multi-Precision by Short Literal								
Syntax:	{label:}	LSRM{.l}	Ws,	lit5,	Wnd				
			[Ws],						
			[Ws++],						
			[Ws--],						
			[++Ws],						
			[--Ws],						
Operands:	Ws ∈ [W0 ... W15]; lit5 ∈ [0...31]; Wnd ∈ [W1 ... W14]								
Operation:	lit5[4:0] → Shift_Val 0 → Right shift input (logical shift) Ws[31:0], 32'b0 → Shift_In[63:0] Logical shift right Shift_In[63:0] by Shift_Val → Shift_Out[63:0] Shift_Out[63:32] → Wnd Shift_Out[31:0] Wnd-1 → Wnd-1								
Status Affected:	N,Z								
Encoding:	1110	000k	kkkk	dddd	pppU	UUss	ssUU	0111	
Description:	<p>Logical shift right the contents of the source register Ws by lit5 bits (up to 31 positions), placing the result in the destination register Wnd. The register containing the next least significant data word will already contain an intermediate shift result. Bitwise OR this value with the data shifted out of Ws in order to create the final shift result, then update the corresponding destination register. The Z bit is “sticky” (can only be cleared).</p> <p>The ‘s’ bits select the source register.</p> <p>The ‘d’ bits select the destination register.</p> <p>The ‘p’ bits select the source addressing mode.</p> <p>The ‘k’ bits provide the literal operand.</p> <p>Notes:</p> <ol style="list-style-type: none"> 1. The N flag can only be set if the MSb of Ws = 1 with a shift value of zero. 2. This instruction operates in Long Word mode only. 								
I-Words:	1								
Cycles:	2								

LSRM	Logical Shift Right Multi-Precision by Wb								
Syntax:	{label:}	LSRM{.l}	Ws,	Wb,	Wnd				
			[Ws],						
			[Ws++],						
			[Ws--],						
			[++Ws],						
			[--Ws],						
Operands:	Ws ∈ [W0 ... W15]; Wb ∈ [W0 ... W15]; Wnd ∈ [W1 ... W14]								
Operation:	Wb[15:0] → Shift_Val 0 → Right shift input (logical shift) Ws[31:0], 32'b0 → Shift_In[63:0] Logical shift right Shift_In[63:0] by Shift_Val → Shift_Out[63:0] Shift_Out[63:32] → Wnd Shift_Out[31:0] Wnd-1 → Wnd-1								
Status Affected:	N,Z								
Encoding:	1110	001U	ssss	dddd	pppU	UUww	wwUU	0111	
Description:	<p>Logical shift right the contents of the source register Ws by Wb bits, placing the result in the destination register Wnd. The register containing the next least significant data word will already contain an intermediate shift result. Bitwise OR this value with the data shifted out of Ws in order to create the final shift result, then update the corresponding destination register.</p> <p>The right shift may be by any amount between zero and 32 bits. Should the shift value held in Wb[15:0] exceed 2'd32, the shift value will saturate to 2'd32 for consistency. Any data held in Wb[31:16] will have no effect.</p> <p>The Z bit is "sticky" (can only be cleared).</p> <p>The 'w' bits select the base (shift count) register.</p> <p>The 's' bits select the source register.</p> <p>The 'd' bits select the destination register.</p> <p>The 'p' bits select the source addressing mode.</p> <p>Note: This instruction operates in Long Word mode only.</p>								
I-Words:	1								
Cycles:	2								

LUAC		Load Upper Accumulator			
Syntax:	{label:}	LUAC.l	Ws,	{ Slit6, }	A
			[Ws],		B
			[Ws++]		
			[Ws--]		
			[-Ws],		
			[++Ws],		
			[Ws+Wb],		
Operands:	Ws ∈ [W0 ... W15]; Wb ∈ [W0 ... W15]; Slit6 ∈ [-32 ... +31]				
Operation:	Ws[7:0] → ACC[71:64] Shift _{Slit6} (ACC) → ACC				
Status Affected:	OA, SA or OB, SB				
Encoding:	1100	11A1	www	sss	pppU UUkk kkkk 1011
Description:	<p>Read the contents of the Effective Address. Place the LSb of the data read into the upper 8-bits of the target accumulator (ACCx[71:64]), then optionally arithmetically shift the entire accumulator. The 'A' bits specify the destination accumulator.</p> <p>The 's' bits specify the source register Wns.</p> <p>The 'p' bits select the source addressing mode.</p> <p>The 'w' bits specify the offset register Wb.</p> <p>The 'k' bits encode the optional operand Slit6 which determines the amount of the accumulator shift; if the operand Slit6 is absent, the literal bit field is set to all 0's.</p> <p>Note: Positive values of operand Slit6 represent arithmetic shift right. Negative values of operand Slit6 represent shift left.</p>				
I-Words:	1				
Cycles:	1				

Example:1 LUAC A, #4, w8 ; Load ACCAU from w8[7:0];Right shift value of ACCA by 4

Before execution		After execution	
ACCA	0x00_1022_2EE1_5633_9078	ACCA	0xFF_F102_22EE_1563_3907
w8	0x000000FF	w8	0x000000FF

MAC	Multiply and Accumulate						
Syntax: {label:}	MAC{.w}	Wx	, Wy,	A	{,AWB}		
	MAC.l	[Wx]	, [Wy],	B			
		[Wx]+=kx	, [Wy]+=ky,				
		[Wx]-=kx	, [Wy]-=ky,				
		[Wx+=kx]	, [Wy+=ky],				
		[Wx-=kx]	, [Wy-=ky],				
		[Wx+W12]	, [Wy+W12],				
Operands:	<p>Wx ∈ {W0 ... W14}; Wy ∈ {W0 ... W14}</p> <p>Word mode: kx ∈ {-8, -6, -4, -2, 2, 4, 6, 8};</p> <p>ky ∈ {-8, -6, -4, -2, 2, 4, 6, 8};</p> <p>Long Word mode: kx ∈ {-16, -12, -8, -4, 4, 8, 12, 16};</p> <p>ky ∈ {-16, -12, -8, -4, 4, 8, 12, 16};</p> <p>AWB ∈ {W0, W1, W2, W3, W13, [W13++], [W15++]³}</p>						
Operation:	<p>(ACC(A or B)) + ((Wx) * (Wy)) → ACC(A or B);</p> <p>(ACC(B or A)) rounded → AWB</p> <p>When Indirect Pre/Post Modified Addressing:</p> <p>(Wx)+kx→Wx or (Wx)-kx→Wx;</p> <p>(Wy)+ky→Wy or (Wy)-ky→Wy;</p>						
Status Affected:	OA,SA or OB,SB						
Encoding:	1101	00AL	www	ssss	IIIi	iJJJ	jjaa a011

Instruction Descriptions (E to MULUU) (continued)

MAC Multiply and Accumulate

Description: Signed/unsigned (defined by CORCON.US) multiply of data read from Wx and Wy or concurrently fetched from the X and Y address space. The result is sign-extended (when at least one operand is considered signed) or zero-extended (when both operands are unsigned) to 72-bits and added to the specified accumulator. Fractional or integer operation (defined by CORCON.IF) will determine if the result is scaled or not prior to the accumulator update. Fractional operation will scale the result to align the operand and accumulator (msw) fractional points (see note 3). Integer operation will align the LSb of the result with the LSb of the accumulator.

When indirect addressing is selected for either or both the X and Y address space, Wx and Wy registers provide the corresponding indirect addresses. The address modifier values are kx and ky, respectively, and represent the number of data bytes by which to modify the Effective Address.

The optional AWB specifies the direct or indirect (see note 4) store of the (32-bit) rounded fractional contents of the accumulator not targeted by the MAC operation. Rounding mode is defined by CORCON.RND. Write data width is determined by selected instruction data size. AWB is not intended for use when the DSP engine is operating in Integer mode.

Data read may be 16-bit or 32-bit values. All indirect address modification is scaled accordingly.

The 'L' bit selects word or long word operation.

The 'A' bit selects the accumulator for the result.

The 'I' bits select the Operation.X-Space Addressing mode.

The 'i' bits select the kx modification value.

The 'J' bits select the Operation.Y-Space Addressing mode.

The 'j' bits select the ky modification value.

The 's' bits select the Wx register

The 'w' bits select the Wy register.

The 'a' bits select the accumulator write-back destination and addressing mode.

Notes:

- Operates in Fractional or Integer Data mode as defined by CORCON.IF.
- MAC register direct where Wx = Wy is equivalent to SQRAC Wx, ACCx
- The LS portion of ACCx is unaffected when operating in Fractional mode with word sized data. Lower significance data that may be present from prior (32-bit data) operations is therefore preserved. Users not requiring this should clear ACCx during initialization.
- Use of the same W-reg for both indirect source (X or Y) and AWB indirect destination is not permitted if the source is a pre- or post-modified Effective Address.
- Stack must remain long word aligned. Consequently, [W15++] AWB is only permitted for use with long word MAC-class instructions.

I-Words: 1
Cycles: 1

```
Example:1  MAC.I      [W2] += 4,
                  [W5] -= 4, A,
                  W13      ;Multiply the contents of W2 and W5 and
                              accumulate the results to ACCA ;Increment
                              W2 by 4; Decrement W5 by 4; ;Write back
                              ACCB to W13
```

Before execution		After execution	
W2	0x5000	W2	0x5004
W5	0x7010	W5	0x700C
W13	0x00000000	W13	0x40210242
CORCON[7:0]	8'b10110000 (Super saturation enabled.)	CORCON[7:0]	8'b10110000 (Super saturation enabled.)
ACCA	0x00_4000000 0_00000000	ACCA	0x00_6000000 0_00000000
ACCB	0x00_4021024 2_29220124	ACCB	0x00_4021024 2_29220124
Data @0x5000	0x40000000	Data @0x5000	0x40000000

Instruction Descriptions (E to MULUU) (continued)

Example:1	MAC.I	[W2] += 4, [W5] -= 4, A, W13	;Multiply the contents of W2 and W5 and accumulate the results to ACCA ;Increment W2 by 4; Decrement W5 by 4; ;Write back ACCB to W13
-----------	-------	------------------------------------	---

Data @0x7010 0x20000000

Data @0x7010 0x20000000

Example:2	MAC.I	[W2+=4], [W5+=4], B	;Increment W2 and W5 by 4; ;Multiply the contents of W2 and W5 and accumulate the results to ACCB
-----------	-------	------------------------	---

Before execution

After execution

W2	0x5000		W2	0x5004	
W5	0x7010		W5	0x7014	
W13	0x00000000		W13	0x40210242	
CORCON[7:0]	8'b111110000	(Super saturation enabled.)	CORCON[7:0]	8'b111110000	(Super saturation enabled.)
ACCA	0x00_40000000		ACCA	0x00_40000000	
	0_00000000			0_00000000	
ACCB	0xFF_E0000000		ACCB	0x00_1FFFFFFF	
	0_00000000			F_00000000	
Data @0x5000	0x40000000		Data @0x5000	0x40000000	
Data @0x7010	0x20000000		Data @0x7010	0x20000000	
Data @0x5004	0x7FFFFFFF		Data @0x5004	0x7FFFFFFF	
Data @0x7014	0x40000000		Data @0x7014	0x40000000	

MAX		Force (Signed) Maximum Data Range Limit						
Syntax:	{label:}	MAX{.w}	Wb,	Ws				
		MAX.l		[Ws]				
				[Ws++]				
				[Ws--]				
				[++Ws]				
				[--Ws]				
Operands:	Ws ∈ [W0 ... W15]; Wb ∈ [W0 ... W14]							
Operation:	<pre> IF (Ws) > (Wb) THEN { (Wb) → (Ws); 0 → Z; 0 → N; 0 → OV } ELSE { 1 → Z; 0 → N; 0 → OV } </pre>							
Status Affected:	N, Z, OV							
Encoding:	1110	010L	UUUU	ssss	pppU	UUww	wwUU	1111
Description:	<p>Compare any size of signed data value in Ws to a maximum signed limit value held in Wb. For long word data size, if Ws[31:0] is greater than Wb[31:0], set Ws[31:0] to the limit value held in Wb[31:0]. For word data sizes, if Ws[15:0] is greater than Wb[15:0], set Ws[15:0] to the limit value held in Wb[15:0] (Ws[31:16] is ignored). The Z, N and OV status bits are set such that a subsequent BGT instruction will take a branch.</p> <p>If Ws[31:0] is less than or equal to the maximum limit value in Wb[31:0] (for long word data size), or if Ws[15:0] is less than or equal to the maximum limit value in Wb[15:0] (word data size), the data limit is not applied such that contents of Ws will not change (for the given data size). The Z, N and OV status bits are set such that a subsequent BZ or BLE instruction will take a branch.</p> <p>The OV status bit is always cleared by this instruction.</p> <p>The 's' bits select the source (data value) register.</p> <p>The 'w' bits select the base (data limit) register.</p> <p>The 'p' bits select the source addressing mode.</p> <p>Note:</p> <ol style="list-style-type: none"> The status bits are set based upon the data compare result. 							
I-Words:	1							
Cycles:	1							

MAX		Accumulator Force Maximum Data Range Limit	
Syntax:	{label;} MAX	A	B
Operands:	None		
Operation:	<pre> IF (MAX A) THEN (IF ACCA - ACCB > 0 THEN (ACCB → ACCA; 0 → Z; 0 → N; 0 → OV;) ELSE (1 → Z; 0 → N; 0 → OV;)) IF (MAX B) THEN (IF ACCB - ACCA > 0 THEN (ACCA → ACCB; 0 → Z; 0 → N; 0 → OV;) ELSE (1 → Z; 0 → N; 0 → OV;)) </pre>		
Status Affected:	N, OV, Z		
Encoding:	0111	001A	UUUU 1101
Description:	<p>Clamp the target accumulator (defined in the instruction) to the maximum limit value previously loaded into the other accumulator.</p> <p>The compare examines the full 72-bit value of the target accumulator and will therefore clamp an overflowed accumulator (variable saturation).</p> <p>If the target accumulator is greater than the limit accumulator, load the target accumulator with the contents of the limit accumulator. The Z and N status bits are set such that a subsequent BGT instruction will take a branch.</p> <p>If the target accumulator is not greater than the limit accumulator, the target accumulator is unaffected. The Z status bit is set such that a subsequent BZ instruction will take a branch.</p> <p>The OV status bit is always cleared by this instruction.</p> <p>The 'A' bit specifies the destination accumulator.</p> <p>Note:</p> <ol style="list-style-type: none"> OA and SA or OB and SB status bits are not modified by this instruction. Execute SFTAC <ACCx>, 0 after MAXAB operation to update DSP status to reflect contents of ACCx. 		
I-Words:	0.5		
Cycles:	1		

MAX		Accumulator Force Maximum Data Range Limit with Limit Excess Result						
Syntax:	{label:}	MAX{.w}{.v} A,		Wd				
		MAX.l{v} B,		[Wd]				
				[Wd++]				
				[Wd--]				
				[++Wd]				
				[--Wd]				
				[Wd+Wb]				
Operands:		Wd ∈ [W0 ... W15] (see note 4); Wb ∈ [W0 ... W15]						
Operation:		<pre> IF (MAX A) THEN (IF ACCA - ACCB > 0 THEN (+1 → Wd OR ACCA - ACCB → Wd (see text); ACCB → ACCA; 0 → Z; 0 → N; 0 → OV;) ELSE (0 → Wd; 1 → Z; 0 → N; 0 → OV;)) IF (MAX B) THEN (IF ACCB - ACCA > 0 THEN (+1 → Wd OR ACCB - ACCA → Wd (see text); ACCA → ACCB; 0 → Z; 0 → N; 0 → OV;) ELSE (0 → Wd; 1 → Z; 0 → N; 0 → OV;)) </pre>						
Status Affected:		N, OV, Z						
Encoding:		1100	10AL	www	ddd	UUUq	qqUU	UUUV 1011

Instruction Descriptions (E to MULUU) (continued)

MAX	Accumulator Force Maximum Data Range Limit with Limit Excess Result
Description:	<p>Clamp the target accumulator (defined in the instruction) to the maximum limit value previously loaded into the other accumulator.</p> <p>The compare examines the full 72-bit value of the target accumulator and will therefore clamp an overflowed accumulator (variable saturation).</p> <p>If the target accumulator is greater than the limit accumulator, load the target accumulator with the contents of the limit accumulator. For MAX (instruction bit field V = 0, default when not declared), set Wd to +1. For MAX.v (instruction bit field V = 1), write the (signed) value by which the limit is exceeded to Wd:</p> <ul style="list-style-type: none"> - Word operation: Consider only bits [47:32] of the compare result and write to Wd (destination is also word-sized, see note 3). If the limit is exceeded by a value greater than that which can be represented by a signed 16-bit number, saturate the Wd write to the maximum 16-bit positive value (i.e., set Wd[15:0] to 0x7FFF). - Long word operation: Consider only bits [31:0] of the compare result and write to Wd. If the limit is exceeded by a value greater than that which can be represented by a signed 32-bit number, saturate the Wd write to the maximum positive value (i.e., set Wd to 0x7FFFFFFF). <p>The Z and N status bits are set such that a subsequent BGT instruction will take a branch if the limit is exceeded.</p> <p>If the target accumulator is not greater than the limit accumulator, the target accumulator is unaffected, and Wd is cleared. The Z status bit is set such that a subsequent BZ instruction will take a branch.</p> <p>The OV status bit is always cleared by this instruction.</p> <p>The 'L' bit selects word or long word operation.</p> <p>The 'A' bit specifies the destination accumulator.</p> <p>The 'd' bits select the destination register.</p> <p>The 'q' bits select the destination addressing mode.</p> <p>The 'w' bits define the offset Wb.</p> <p>The 'V' bit defines the presence and result format for Wd.</p> <p>Notes:</p> <ol style="list-style-type: none"> 1. OA and SA or OB and SB status bits are not modified by this instruction. Execute SFTAC <ACCx>, 0 after MAXAB operation to update DSP status to reflect contents of ACCx. 2. In keeping with all word sized register direct writes, Wd[15:0] will always be zero extended to 32-bits. 3. Register direct destination W15 not permitted.
I-Words:	1
Cycles:	2

MIN		Force (Signed) Minimum Data Range Limit			
Syntax:	{label:}	MIN{.w}	Wb,	Ws	
		MIN.l		[Ws]	
				[Ws++]	
				[Ws--]	
				[++Ws]	
				[--Ws]	
Operands:	Ws ∈ [W0 ... W15]; Wb ∈ [W0 ... W14]				
Operation:	<pre> IF (Ws) < (Wb) THEN { (Wb) → (Ws); 0 → Z; 1 → N; 0 → OV } ELSE { 1 → Z; 0 → N; 0 → OV } </pre>				
Status Affected:	N, Z, OV				
Encoding:	1110	010L	UUUU	ssss	pppU UUww wwUU 1011
Description:	<p>Compare a word or long word signed data value in Ws to a minimum signed limit value held in Wb. For long word data size, if Ws[31:0] is less than Wb[31:0], set Ws[31:0] to the limit value held in Wb[31:0]. For word data sizes, if Ws[15:0] is less than Wb[15:0], set Ws[15:0] to the limit value held in Wb[15:0] (Ws[31:16] is ignored). The Z, N and OV status bits are set such that a subsequent BLT instruction will take a branch.</p> <p>If Ws[31:0] is greater than or equal to the minimum limit value in Wb[31:0] (for long word data size), or if Ws[15:0] is greater than or equal to the minimum limit value in Wb[15:0] (word data size), the data limit is not applied such that contents of Ws will not change (for the given data size). The Z, N and OV status bits are set such that a subsequent BZ or BGE instruction will take a branch.</p> <p>For word sized register direct operations, Ws is always zero extended to 32-bits (even if greater than or equal to the limit value in Wb)².</p> <p>The OV status bit is always cleared by this instruction.</p> <p>The 's' bits select the source (data value) register.</p> <p>The 'w' bits select the base (data limit) register.</p> <p>The 'p' bits select the source addressing mode.</p> <p>Note:</p> <ol style="list-style-type: none"> The status bits are set based upon the data compare result. 				
I-Words:	1				
Cycles:	1				

MIN		Accumulator Force Minimum Data Range Limit (unconditional execution)	
Syntax:	{label:}	MIN	A B
Operands:	None		
Operation:	<pre> IF (MIN A) THEN (IF ACCA - ACCB < 0 THEN (ACCB → ACCA; 0 → Z; 1 → N; 0 → OV;) ELSE (1 → Z; 0 → N; 0 → OV;)) IF (MIN B) THEN (IF ACCB - ACCA < 0 THEN (ACCA → ACCB; 0 → Z; 1 → N; 0 → OV;) ELSE (1 → Z; 0 → N; 0 → OV;)) </pre>		
Status Affected:	N, OV, Z		
Encoding:	0111	001A	UUUU 1011
Description:	<p>Clamp the target accumulator (defined in the instruction) to the minimum limit value previously loaded into the other accumulator.</p> <p>The compare examines the full 72-bit value of the target accumulator and will therefore clamp an overflowed accumulator (variable saturation).</p> <p>If the target accumulator is less than the limit accumulator, load the target accumulator with the contents of the limit accumulator. The Z and N status bits are set such that a subsequent BLT instruction will take a branch.</p> <p>If the target accumulator is not less than the limit accumulator, the target accumulator is unaffected. The Z status bit is set (Z = 1) such that a subsequent BLT instruction will take a branch.</p> <p>The OV status bit is always cleared by this instruction.</p> <p>The 'A' bit specifies the destination accumulator.</p> <p>Note:</p> <ol style="list-style-type: none"> OA and SA or OB and SB status bits are not modified by this instruction. Execute SFTAC <ACCx>, 0 after MAXAB execution to update DSP status to reflect contents of ACCx. 		
I-Words:	0.5		
Cycles:	1		

MIN		Accumulator Force Minimum Data Range Limit with Limit Excess Result (unconditional execution)						
Syntax:	{label:}	MIN{.w}{.v} A,		Wd				
		MIN.l{v}	B,	[Wd]				
				[Wd++]				
				[Wd--]				
				[++Wd]				
				[--Wd]				
				[Wd+Wb]				
Operands:		Wd ∈ [W0 ... W15] (see note 4); Wb ∈ [W0 ... W15]						
Operation:		<pre> IF (MIN A) THEN (IF ACCA - ACCB < 0 THEN (-1 → Wd OR ACCA - ACCB → Wd (see text); ACCB → ACCA; 0 → Z; 1 → N; 0 → OV;)) ELSE (0 → Wd; 1 → Z; 0 → N; 0 → OV;) IF (MIN B) THEN (IF ACCB - ACCA < 0 THEN (-1 → Wd OR ACCB - ACCA → Wd (see text); ACCA → ACCB; 0 → Z; 1 → N; 0 → OV;)) ELSE (0 → Wd; 1 → Z; 0 → N; 0 → OV;)) </pre>						
Status Affected:		N, OV, Z						
Encoding:		1100	10AL	www	ddd	UUUq	qqUU	UUUV 0011

Instruction Descriptions (E to MULUU) (continued)

MIN	Accumulator Force Minimum Data Range Limit with Limit Excess Result (unconditional execution)
Description:	<p>Clamp the target accumulator (defined in the instruction) to the minimum limit value previously loaded into the other accumulator.</p> <p>The compare examines the full 72-bit value of the target accumulator and will therefore clamp an overflowed accumulator (variable saturation).</p> <p>If the target accumulator is less than the limit accumulator, load the target accumulator with the contents of the limit accumulator. For MIN (instruction bit field V = 0, default when not declared), set Wd to -1. For MIN.v (instruction bit field V = 1), write the (signed) value by which the limit is exceeded to Wd:</p> <ul style="list-style-type: none"> - Word operation: consider only bits [47:32] of the compare result and write to Wd (destination is also word sized, see note 3). If the limit is exceeded by a value greater than that which can be represented by a signed 16-bit number, saturate the Wd write to the maximum 16-bit negative value (i.e., set Wd[15:0] to 0x8000). - Long word operation: consider only bits [31:0] of the compare result and write to Wd. If the limit is exceeded by a value greater than that which can be represented by a signed 32-bit number, saturate the Wd write to the maximum negative value (i.e., set Wd to 0x80000000). <p>The Z and N status bits are set such that a subsequent BLT instruction will take a branch if the limit is exceeded.</p> <p>If the target accumulator is not less than the limit accumulator, the target accumulator is unaffected, and Wd is cleared. The Z status bit is set such that a subsequent BZ instruction will take a branch.</p> <p>The OV status bit is always cleared by this instruction.</p> <p>The 'L' bit selects word or long word operation.</p> <p>The 'A' bit specifies the destination accumulator.</p> <p>The 'd' bits select the destination register.</p> <p>The 'q' bits select the destination addressing mode.</p> <p>The 'w' bits define the offset Wb.</p> <p>The 'V' bit defines the result format for Wd.</p> <p>Notes:</p> <ol style="list-style-type: none"> 1. OA and SA or OB and SB status bits are not modified by this instruction. Execute SFTAC <ACCx>, 0 after MINABW execution to update DSP status to reflect contents of ACCx. 2. In keeping with all word-sized register direct writes, Wd[15:0] will always be zero extended to 32-bits (irrespective of the sign of the result). 3. Register direct destination W15 not permitted.
I-Words:	1
Cycles:	2

MOV		Move f to Wnd (Word or Long)					
Syntax:	{label;} MOV{.w} f, Wnd MOV.l						
Operands:	f ∈ [0 ... 1MB]; Wnd ∈ [W0 ... W15]						
Operation:	(f) → Wnd						
Status Affected:	None						
Encoding:	1001 00dd ffff ffff ffff ffff fffL dd01						
Description:	Moves the contents of any file register to the specified W register. The file address is a word address. Word data will be zero-extended to 32-bits prior to destination write. The 'L' bit selects word or long word operation. The 'f' bits select the address of the file register. The 'd' bits select the destination register.						
	Notes:						
	1. Accessible file address space is 1MB.						
	2. The file address is always either word or long word aligned. The opcode does not store the LSB because it is always 1'b0.						
I-Words:	1						
Cycles:	1						

MOV	Move f to Wnd (Byte)								
Syntax:	{label:}	MOV.bz	f,	Wnd					
Operands:	f ∈ [0 ... 1MB]; Wnd ∈ [W0 ... W14]								
Operation:	(f) → Wnd								
Status Affected:	None								
Encoding:	1001	10dd	ffff	ffff	ffff	ffff	ffff	ffff	dd01
Description:	<p>Moves contents of any file register to the specified W register. The file address is a byte address. The byte data will be zero-extended to 32-bits prior to destination write.</p> <p>The 'f' bits select the address of the file register.</p> <p>The 'd' bits select the destination register.</p>								
I-Words:	1								
Cycles:	1								

MOV	Move Wns to f (Byte)								
Syntax:	{label:}	MOV.b	Wns	f					
Operands:	f ∈ [0 ... 1MB]; Wns ∈ [W0 ... W15]								
Operation:	Wns → (f)								
Status Affected:	None								
Encoding:	1001	11ss	ffff	ffff	ffff	ffff	ffff	ffff	ss01
Description:	<p>Moves contents of the specified W register to any file register. The file address is a byte address. The 'f' bits select the address of the file register.</p> <p>The 's' bits select the source register.</p>								
I-Words:	1								
Cycles:	1								

MOV	Move Wns to f (Word/Long)								
Syntax:	{label:}	MOV{.w}	Wns	f					
		MOV.l							
Operands:	f ∈ [0 ... 1MB]; Wns ∈ [W0 ... W15]								
Operation:	Wns → (f)								
Status Affected:	None								
Encoding:	1001	01ss	ffff	ffff	ffff	ffff	fffL	ss01	
Description:	<p>Moves contents of the specified W register to any file register. The file address is a word address. The 'L' bit selects word or long word operation.</p> <p>The 'f' bits select the address of the file register.</p> <p>The 's' bits select the source register.</p> <p>Note: The file address is always either word or long word aligned. The opcode does not store the LSb because it is always 1'b0.</p>								
I-Words:	1								
Cycles:	1								

MOV	Move Wns with Signed Literal Offset to Wnd								
Syntax:	{label:}	MOV.b	[Wns+Slit12], Wnd						
		MOV.bz	[Wns+Slit12], Wnd						
		MOV{.w}	[Wns+Slit13], Wnd						
		MOV.l	[Wns+Slit14], Wnd						
Operands:	Wns ∈ [W0 ... W15] Wnd ∈ [W0 ... W15]								
Operation:	[Wns+Slit12/13/14] → Wnd								
Status Affected:	None								
Encoding:	1111	110L	dddd	ssss	kkkk	kkkk	kkkk	B011	
Description:	<p>Moves contents of the source Effective Address to a specified W register. The contents of Wns are not modified by this operation.</p> <p>The instruction encoding includes space for a 12-bit literal which is scaled accordingly for byte, word and long word data moves in order to generate the corresponding byte offset value.</p> <p>The 'L' and 'B' bits select operation data width.</p> <p>The 'd' bits select the destination register.</p> <p>The 's' bits select the source register.</p> <p>The 'k' bits specify the literal operand.</p>								
I-Words:	1								
Cycles:	1								

MOV		Move Ws to f (extended)							
Syntax:	{label:}	MOV.l	Ws,	f					
		MOV{.w}	[Ws],						
		MOV{.b}	[Ws++],						
			[Ws--],						
			[++Ws],						
			[--Ws],						
Operands:	f ∈ [1MB ¹ ... 4GB]; Ws ∈ [W0 ... W15]								
Operation:	Ws → (f)								
Status Affected:	None								
Encoding:									
1st word	1111	001U	ffff	ffff	ffff	ffff	ffff	ffff	U011
2nd word	1111	001L	ssss	Ufff	pppf	ffff	ffff	ffff	B111
Description:	<p>Moves contents of Ws to any file register. The file address is a byte address. The 's' bits select the Working register. The 'p' bits select the source addressing mode. The 'f' bits select the address of the file register: file[31:0] = Word1[18:13], Word2[9:4], Word1[23:4]</p>								
I-Words:	2								
Cycles:	2								

MOV		Move Wns to Wnd with Signed Literal Offset						
Syntax:	{label:}	MOV.b	Wns, [Wnd+Slit12]					
		MOV{.w}	Wns, [Wnd+Slit13]					
		MOV.l	Wns, [Wnd+Slit14]					
Operands:	Wnd ∈ [W0 ... W15] Wns ∈ [W0 ... W15]							
Operation:	Wns → [Wnd+Slit12/13/14]							
Status Affected:	None							
Encoding:	1111	110L	dddd	ssss	kkkk	kkkk	kkkk	B111
Description:	<p>Moves contents of a specified W register to the destination Effective Address. The contents of Wnd are not modified by this operation.</p> <p>The instruction encoding includes space for a 12-bit literal which is scaled accordingly for byte, word and long word data moves in order to generate the corresponding byte offset value.</p> <p>The 'L' and 'B' bits select operation data width.</p> <p>The 'd' bits select the destination register.</p> <p>The 's' bits select the source register.</p> <p>The 'k' bits specify the literal operand.</p>							
I-Words:	1							
Cycles:	1							

MOV		Move Ws to Wd	
Syntax:	{label:}	MOV.b	Ws, Wd
		MOV.bz	[Ws], [Wd]
		MOV{.w}	[Ws++] [Wd++]
		MOV.l	[Ws--] [Wd--]
			[-Ws], [-Wd]
			[++Ws], [++Wd]
			[Ws+Wb], [Wd+Wb]
		SR	SR
Operands:	Ws ∈ [W0 ... W15]; Wd ∈ [W0 ... W15]; Wb ∈ [W0 ... W14] (see Note 6)		
Operation:	(EAs) → (EAd)		
Status Affected:	None (see note 3)		
Encoding:	s000	001L	dddd ssss pppq qqww wwUU B000
Description:	<p>Move the contents of the source register into the destination register. The 'S' bit selects instruction size. The 'L' and 'B' bits select operation data width. The 's' bits select the source register. The 'd' bits select the destination register. The 'p' bits select the source addressing mode. The 'q' bits select the destination addressing mode. The 'w' bits define the offset Wb.</p> <p>Notes:</p> <ol style="list-style-type: none"> When targeting the SR, the SR will be modified as a result of the instruction operation. .bz data size/mode is disallowed when writing to the SR. If register offset addressing is used for both source and destinations addressing modes, Wb cannot be set to W15. 		
I-Words:	1 or 0.5		
Cycles:	1		

Example 1:		MOV.B [W0--], W4 ; Move [W0] to W4 (Byte mode) ; Post-decrement W0	
		Before Instruction	After Instruction
	W0	0A01	W0 0A00
	W4	2976	W4 2989
Data	0A00	8988	Data 0A00 8988
	SR	0000	SR 0000

MOV	Move Literal to Wnd						
Syntax:	{label:}	MOV.bz	lit8	Wnd			
		MOV{.w}	lit16				
		MOV.sl	lit24				
Operands:	lit8 ∈ [0 ... 255]; lit16 ∈ [0 ... 65535]; lit24 ∈ [0 ... 16MB]; Wnd ∈ [W0 ... W15]						
Operation:	8'h00, lit24 → Wnd						
Status Affected:	None						
Encoding:	10dd	ddkk	kkkk	kkkk	kkkk	kkkk	kk11
Description:	<p>The literal 'k' is zero-extended to 32-bits then loaded into the Wnd register. The 'd' bits select the Working register.</p> <p>The 'k' bits specify the value of the 8-bit, 16-bit or 24-bit literal. The 8-bit and 16-bit literals are zero extended by the assembler to generate the 24-bit value for the opcode.</p>						
I-Words:	1						
Cycles:	1						

MOV		Move Long Literal to Wd							
Syntax:	{label;} MOV.l lit32, Wd [Wd] [Wd++] [Wd--] [++Wd] [--Wd]								
Operands:	lit32 ∈ [0 ... 4GB]; Wd ∈ [W0 ... W15]								
Operation:	lit32 → Wd								
Status Affected:	None								
Encoding:									
1st word	1000 000U kkkk kkkk kkkk kkkk kkkk U001								
2nd word	1000 000U dddd Ukkk kkkq qqkk kkkk U101								
Description:	The literal 'k' is loaded into the Wd register. The 'd' bits select the Working register. The 'q' bits select the destination addressing mode. The 'k' bits specify the value of the 32-bit literal: lit32[31:0] = Word2[18:13], Word2[9:4], Word1[23:4]								
I-Words:	2								
Cycles:	2								

MOV	Move Short Literal to Wnd			
Syntax:	{label:}	MOV.l	lit5,	Wnd
Operands:	lit5 ∈ [0 ... 31]; Wnd ∈ [W0 ... W14]			
Operation:	27'h0000000, lit5 → Wnd			
Status Affected:	None			
Encoding:	0001	000k	kkkk	dddd
Description:	<p>The literal 'k' is zero-extended to 32-bits then loaded into the Wnd register. The 'd' bits select the Working register. The 'k' bits specify the value of the 5-bit literal.</p>			
I-Words:	0.5			
Cycles:	1			

MOV		Move Ws to Wd with Bit-Reversed Addressing					
Syntax:	{label:}	MOVR{.w} Ws,		[Wd++]			
		MOVR.l	[Ws],	[++Wd]			
			[Ws++],				
			[++Ws],				
Operands:		Ws ∈ [W0 ... W14]; Wd ∈ [W0 ... W14]					
Operation:		(EAs) → (EAd) with Bit-Reversed Addressing					
Status Affected:		None					
Encoding:		1000	001L	dddd	ssss	pppq	qqUU
							UUUU
							1100
Description:		<p>Move the contents of the source address to the destination address using Bit-Reversed Addressing to generate the destination EA. The destination Bit-Reversed Addressing modifier is sourced from XBREV.XB[14:0].</p> <p>The 'L' bit selects operation data width.</p> <p>The 's' bits select the source register.</p> <p>The 'd' bits select the destination register.</p> <p>The 'p' bits select the source addressing mode.</p> <p>The 'q' bits select the destination addressing mode.</p> <p>Note:</p> <ol style="list-style-type: none"> Ws = Wd only permitted when Source Addressing mode is register indirect without modification ([Ws]). 					
I-Words:		1					
Cycles:		1					

MOV	Move from Stack with Literal Offset to Wnd		
Syntax:	{label:}	MOV.l	[W15-lit7], Wnd [W14+slit7], Wnd
Operands:	Wnd ∈ [W0 ... W14]; lit7 ∈ [4, 8 124, 128] (see note 2) slit7 ∈ [-64, -60 +56, +60]		
Operation:	((W15 - lit7) → Wnd or ((W14 + slit7) → Wnd		
Status Affected:	None		
Encoding:	0000	11Fk	kkkk dddd
Description:	<p>Move the contents of the system stack to the destination register using the SP (W15) or FP (W14) as source address with a (byte) offset. The stack source Effective Address is defined as [W15 - lit7] or [W14 + slit7], but is aligned to a 32-bit boundary (i.e., long word data moves only). The offset used by the CPU is a signed value generated from the 5-bit literal stored within the opcode. The Effective Address is long word aligned such that the LS 2-bits of the address are always 2'b00.</p> <ul style="list-style-type: none"> • When W15 is the source address register, the offset is always negative so the sign bit is implied (i.e., not stored within the opcode) as 1'b1. The assembler will generate the 2's complement of lit7, truncate it, and drop the sign bit to create the 5-bit opcode literal value. An offset of zero cannot be supported. • When W14 is the source address register, the offset may be positive or negative, so the sign bit is stored within the 5-bit literal. The assembler will truncate Slit7 to create the 5-bit opcode literal value. The 'd' bits select the destination register. The 'F' bit selects between W15 (F = 0) and W14 (F = 1). The 'k' bits define a 5-bit signed literal. <p>Note:</p> <ol style="list-style-type: none"> 1. This instruction operates in Long Word mode only. 		
I-Words:	0.5		
Cycles:	1		

MOV	Move Wns to Stack with Literal Offset			
Syntax:	{label:}	MOV.l	Wns,	[W15 - lit7] [W14 + slit7]
Operands:	Wns ∈ [W0 ... W14]; lit8 ∈ [4, 8 124, 128] (see note 2) slit7 ∈ [-64, -60 +56, +60]			
Operation:	Wns → ([W15 - lit7]) or Wns → ([W14 + slit7])			
Status Affected:	None			
Encoding:	0000	10Fk	kkkk	ssss
Description:	<p>Move the contents of the system stack to the destination register using the SP (W15) or FP (W14) as destination address with a (byte) offset. The stack destination Effective Address is defined as [W15 - lit7] or [W14 + slit7], but is aligned to a 32-bit boundary (i.e., long word data moves only). The offset used by the CPU is a signed value generated from the 5-bit literal stored within the opcode. The Effective Address is long word aligned such that the LS 2-bits of the address are always 2'b00.</p> <ul style="list-style-type: none"> • When W15 is the destination address register, the offset is always negative so the sign bit is implied (i.e., not stored within the opcode) as 1'b1. The assembler will generate the 2's complement of lit7, truncate it, and drop the sign bit to create the 5-bit opcode literal value. An offset of zero cannot be supported. • When W14 is the destination address register, the offset may be positive or negative, so the sign bit is stored within the 5-bit literal. The assembler will truncate Slit7 to create the 5-bit opcode literal value. <p>The 's' bits select the source register. The 'F' bit selects between W15 (F = 0) and W14 (F = 1). The 'k' bits specify the literal operand.</p> <p>Note:</p> <ol style="list-style-type: none"> 1. This instruction operates in Long Word mode only. 			
I-Words:	0.5			
Cycles:	1			

MOVIF		Conditionally Move Wb or Wns to Wd							
Syntax:	{label:}	MOVIF.b	CC,	Wb,	Wns,	Wd			
		MOVIF.bz				[Wd]			
		MOVIF{.w}				[Wd++]			
		MOVIF.l				[Wd--]			
						[--Wd]			
						[++Wd]			
Operands:		Wb ∈ [W0 ... W15]; Wns ∈ [W0 ... W15]; Wd ∈ [W0 ... W15] CC ∈ Z, N, C, OV, GT, LT, GTU							
Operation:		If CC = true then Wb → (EAd) Else Wns → (EAd)							
Status Affected:		None							
Encoding:		1111	011L	dddd	ssss	rrrq	qqww	wwUU	B011
Description:		Test the specified condition. If true, move the contents of the Wb source register into the destination, else move the contents of the Wns source register into the destination. The 'L' and 'B' bits select operation data width. The 'w' bits select the (condition true) Wb source register. The 's' bits select the (condition false) Ws source register. The 'd' bits select the destination register. The 'q' bits select the destination addressing mode. The 'r' bits select the move condition.							
I-Words:		1							
Cycles:		1							

Example:1	MOVIF	Z, W5, W6, W1	;Move W5 to W1 if Z == 1; else move W6 to W1
		Before execution	After execution
	W5	0x11111111	W5 0x11111111
	W6	0x22222222	W6 0x22222222
	W1	0x00000000	W1 0x11111111
	SR[7:0]	8'bxxxxxxx1x (Z = 1)	SR[7:0] 8'bxxxxxxx1x (Z = 1)

Example:2	MOVIF	C, W5, W6, W1	;Move W5 to W1 if C == 1; else move W6 to W1
		Before execution	After execution
	W5	0x11111111	W5 0x11111111
	W6	0x22222222	W6 0x22222222
	W1	0x00000000	W1 0x22222222
	SR[7:0]	8'bxxxxxxx0 (C = 0)	SR[7:0] 8'bxxxxxxx0 (C = 0)

MOVS		Move Signed Literal to Wd					
Syntax:	{label:}	MOVS.b	slit16,	Wd			
		MOVS{.w}		[Wd]			
		MOVS.l		[Wd++]			
				[Wd--]			
				[++Wd]			
				[--Wd]			
				SR			
Operands:	slit16 \in [-32768 ... 32767]; Wd \in [W0 ... W15]						
Operation:	Byte: slit16[7:0] \rightarrow (EAd[7:0]) Word: slit16[15:0] \rightarrow (EAd[15:0]) Long or Word Register Direct: {16{slit16[15]}}, slit16[15:0] \rightarrow (EAd[31:0])						
Status Affected:	None (see note 4)						
Encoding:	1000	1kkk	dddd	kkkk	kkkq	qqkk	kkkk LB01
Description:	<p>Write a signed literal value to the destination.</p> <p>MOVS.b will move the LS 8-bits of the literal to the destination. For Register Direct Addressing, the remaining bits of the register will be unaffected.</p> <p>MOVS.w will move the 16-bit literal to the destination (see Note 1). For Register Direct Addressing, the value will be sign-extended to 32-bits.</p> <p>MOVS.l will sign extend the literal to 32-bits prior to moving the value to the destination.</p> <p>The 'L' and 'B' bits select operation data width.</p> <p>The 'd' bits select the Working register.</p> <p>The 'q' bits select the destination addressing mode.</p> <p>The 'k' bits specify the value of the literal. For .b mode, the 8-bit literal value is zero extended by the assembler to generate the 16-bit value for the opcode.</p> <p>Notes:</p> <ol style="list-style-type: none"> For byte sized data, the literal can be considered to be a signed or unsigned value because only an 8-bit value is written. The declared slit16 literal value must be between 0x0000 and 0x00FF. For word size data using any Indirect Addressing mode, the literal can be considered to be a signed or unsigned value because only a 16-bit value is written. Long Word and Word Register Direct Addressing modes are equivalent operations because both sign-extend the literal to 32-bits. When targeting the SR, the SR will be modified as a result of the instruction operation. 						
I-Words:	1						
Cycles:	1						

MPY	Multiply to Accumulator			
Syntax: {label:}	MPY{.w}	Wx	, Wy,	A {,AWB}
	MPY.l	[Wx]	, [Wy],	B
		[Wx]+=kx	, [Wy]+=ky,	
		[Wx]-=kx	, [Wy]-=ky,	
		[Wx+=kx]	, [Wy+=ky],	
		[Wx-=kx]	, [Wy-=ky],	
		[Wx+W12]	, [Wy+W12],	
Operands:	Wx ∈ {W0 ... W14}; Wy ∈ {W0 ... W14} Word mode: kx ∈ {-8, -6, -4, -2, 2, 4, 6, 8}; ky ∈ {-8, -6, -4, -2, 2, 4, 6, 8}; Long Word mode: kx ∈ {-16, -12, -8, -4, 4, 8, 12, 16}; ky ∈ {-16, -12, -8, -4, 4, 8, 12, 16}; AWB ∈ {W0, W1, W2, W3, W13, [W13++], [W15++] ³ }			
Operation:	((Wx) * (Wy)) → ACC(A or B); (ACC(B or A)) rounded → AWB When Indirect Pre/Post Modification Addressing: (Wx)+kx→Wx or (Wx)-kx→Wx; (Wy)+ky→Wy or (Wy)-ky→Wy;			
Status Affected:	OA,SA or OB,SB			
Encoding:	1101	01AL	www	sss IIIi iJJJ jjaa a011
Description:	Signed/unsigned (defined by CORCON.US) multiply of data read from Wx and Wy or concurrently fetched from the X and Y address space. The result is sign-extended (when at least one operand is considered signed) or zero-extended (when both operands are unsigned) to 72-bits then written to the specified accumulator. Fractional results are also scaled prior to the accumulator update to align the operand and accumulator (msw) fractional points. When indirect addressing is selected for either or both the X and Y address space, Wx and Wy registers provide the corresponding indirect addresses. The address modifier values are kx and ky, respectively, and represent the number of data bytes by which to modify the Effective Address. The optional AWB specifies the direct or indirect (see note 2) store of the (32-bit) rounded fractional contents of the accumulator not targeted by the MPY operation. Rounding mode is defined by CORCON.RND. Write data width is determined by selected instruction data size (see note 3). AWB is not intended for use when the DSP engine is operating in Integer mode. Data read may be 16-bit or 32-bit values. All indirect address modification is scaled accordingly. The 'L' bit selects word or long word operation. The 'A' bit selects the accumulator for the result. The 'I' bits select the Operation.X-Space Addressing mode. The 'i' bits select the kx modification value. The 'J' bits select the Operation.Y-Space Addressing mode. The 'j' bits select the ky modification value. The 's' bits select the Wx register The 'w' bits select the Wy register. The 'a' bits select the accumulator write-back destination and addressing mode.			
	Notes:			
	1. Operates in Fractional or Integer Data mode as defined by CORCON.IF. 2. Use of the same W-reg for both indirect source (X or Y) and AWB indirect destination is not permitted if the source is a pre- or post-modified Effective Address. 3. Stack must remain long word aligned. Consequently, [W15++] AWB is only permitted for use with long word MAC-class instructions.			
I-Words:	1			
Cycles:	1			

Example:1 **MPY.L** **[w4] +=4, [w5] +=4, A** ; Multiply W4*W5 and store to ACCA; Post-increment W4 by 4; Post-increment W5 by 4; CORCON = 0x0000 (fractional multiply, no saturation)

Before Instruction		After Instruction	
W4	4014	W4	4018
W5	402C	W5	4030
ACCA	FF F780 2087 0000 0000	ACCA	00 3800 0000 0000 0000
Data	4014 C0000000	Data	4014 C0000000
Data	402C 90000000	Data	402C 90000000
CORCON	0000	CORCON	0000
SR	0000	SR	0000

Example:2 **MPY.L** **[w4] +=4, [w5 +=4], B** ; increment W5 by 4; Multiply W4*W5 and store to ACCB; Post-increment W4 by 4; CORCON = 0x0000 (fractional multiply, no saturation)

Before Instruction		After Instruction	
W4	4014	W4	4018
W5	4028	W5	402C
ACCB	00 9834 4500 0000 0055	ACCB	FF E954 3748 0000 0000
Data	4014 671F0000	Data	4014 671F0000
Data	402C E3DC0000	Data	402C E3DC0000
CORCON	0000	CORCON	0000
SR	0000	SR	0000

MPYN	Negated Multiply to Accumulator			
Syntax: {label:}	MPYN{.w} Wx	, Wy,	A	{,AWB}
	MPYN.l	[Wx]	, [Wy],	B
		[Wx]+=kx	, [Wy]+=ky,	
		[Wx]-=kx	, [Wy]-=ky,	
		[Wx+=kx]	, [Wy+=ky],	
		[Wx-=kx]	, [Wy-=ky],	
		[Wx+W12]	, [Wy+W12],	
Operands:	Wx ∈ {W0 ... W14}; Wy ∈ {W0 ... W14} Word mode: kx ∈ {-8, -6, -4, -2, 2, 4, 6, 8}; ky ∈ {-8, -6, -4, -2, 2, 4, 6, 8}; Long Word mode: kx ∈ {-16, -12, -8, -4, 4, 8, 12, 16}; ky ∈ {-16, -12, -8, -4, 4, 8, 12, 16}; AWB ∈ {W0, W1, W2, W3, W13, [W13++], [W15++] ² }			
Operation:	- ((Wx) * (Wy)) → ACC(A or B); (ACC(B or A)) rounded → AWB When Indirect Pre/Post Modification Addressing: (Wx)+kx→Wx or (Wx)-kx→Wx; (Wy)+ky→Wy or (Wy)-ky→Wy;			
Status Affected:	OA,SA or OB,SB			
Encoding:	1101	01AL	www	ssss IIIi iJJJ jjaa a111
Description:	Signed/unsigned (defined by CORCON.US) multiply of data read from Wx and Wy or concurrently fetched from the X and Y address space. The result is sign-extended (when at least one operand is considered signed) or zero-extended (when both operands are unsigned) to 72-bits, negated and then written to the specified accumulator. Fractional results are also scaled prior to the accumulator update to align the operand and accumulator (msw) fractional points. When indirect addressing is selected for either or both the X and Y address space, Wx and Wy registers provide the corresponding indirect addresses. The address modifier values are kx and ky, respectively, and represent the number of data bytes by which to modify the Effective Address. The optional AWB specifies the direct or indirect store of the (32-bit) rounded fractional contents of the accumulator not targeted by the MPYN operation. Rounding mode is defined by CORCON.RND. Write data width is determined by selected instruction data size (see note 3). AWB is not intended for use when the DSP engine is operating in Integer mode. Data read may be 16-bit or 32-bit values. All indirect address modification is scaled accordingly. The 'L' bit selects word or long word operation. The 'A' bit selects the accumulator for the result. The 'I' bits select the Operation.X-Space Addressing mode. The 'i' bits select the kx modification value. The 'J' bits select the Operation.Y-Space Addressing mode. The 'j' bits select the ky modification value. The 's' bits select the Wx register The 'w' bits select the Wy register. The 'a' bits select the accumulator write-back destination and addressing mode.			
	Notes:			
	1. Operates in Fractional or Integer Data mode as defined by CORCON.IF. 2. Use of the same W-reg for both indirect source (X or Y) and AWB indirect destination is not permitted if the source is a pre- or post-modified Effective Address. 3. Stack must remain long word aligned. Consequently, [W15++] AWB is only permitted for use with long word MAC-class instructions.			
I-Words:	1			
Cycles:	1			

MSC	Multiply and Subtract from Accumulator						
Syntax: {label:}	MSC{.w}	Wx	,	Wy,	A	{,AWB}	
	MSC.l	[Wx]	,	[Wy],	B		
		[Wx]+=kx	,	[Wy]+=ky,			
		[Wx]-=kx	,	[Wy]-=ky,			
		[Wx+=kx]	,	[Wy+=ky],			
		[Wx-=kx]	,	[Wy-=ky],			
		[Wx+W12]	,	[Wy+W12],			
Operands:	Wx ∈ {W0 ... W14}; Wy ∈ {W0 ... W14} Word mode: kx ∈ {-8, -6, -4, -2, 2, 4, 6, 8}; ky ∈ {-8, -6, -4, -2, 2, 4, 6, 8}; Long Word mode: kx ∈ {-16, -12, -8, -4, 4, 8, 12, 16}; ky ∈ {-16, -12, -8, -4, 4, 8, 12, 16}; AWB ∈ {W0, W1, W2, W3, W13, [W13++], [W15++] ³ }						
Operation:	(ACC(A or B)) - ((Wx) * (Wy)) → ACC(A or B); (ACC(B or A)) rounded → AWB When Indirect Pre/Post Modified Addressing: (Wx)+kx→Wx or (Wx)-kx→Wx; (Wy)+ky→Wy or (Wy)-ky→Wy;						
Status Affected:	OA,SA or OB,SB						
Encoding:	1101	00AL	www	ssss	IIIi	iJJJ	jjaa a111

Instruction Descriptions (E to MULUU) (continued)

MSC Multiply and Subtract from Accumulator

Description: Signed/unsigned (defined by CORCON.US) multiply of data read from Wx and Wy or concurrently fetched from the X and Y address space. The result is sign-extended (when at least one operand is considered signed) or zero-extended (when both operands are unsigned) to 72-bits, and then subtracted from the specified accumulator. Fractional or integer operation (defined by CORCON.IF) will determine if the result is scaled or not prior to the accumulator update. Fractional operation will scale the result to align the operand and accumulator (msw) fractional points. Integer operation will align the LSb of the result with the LSb of the accumulator. For word sized operand operations, ACCx[31:0] (Integer mode) or ACCx[32:0] (Fractional mode) is preserved (see note 2).

When indirect addressing is selected for either or both the X and Y address space, Wx and Wy registers provide the corresponding indirect addresses. The address modifier values are kx and ky, respectively, and represent the number of data bytes by which to modify the Effective Address.

The optional AWB specifies the direct or indirect store of the (32-bit) rounded fractional contents of the accumulator not targeted by the MSC operation. Rounding mode is defined by CORCON.RND. Write data width is determined by selected instruction data size (see note 4). AWB is not intended for use when the DSP engine is operating in Integer mode.

Data read may be 16-bit or 32-bit values. All indirect address modification is scaled accordingly.

The 'L' bit selects word or long word operation.

The 'A' bit selects the accumulator for the result.

The 'I' bits select the Operation.X-Space Addressing mode.

The 'i' bits select the kx modification value.

The 'J' bits select the Operation.Y-Space Addressing mode.

The 'j' bits select the ky modification value.

The 's' bits select the Wx register

The 'w' bits select the Wy register.

The 'a' bits select the accumulator write-back destination and addressing mode.

Notes:

- Operates in Fractional or Integer Data mode as defined by CORCON.IF.
- The LS portion of ACCx is unaffected when operating in Fractional mode with word sized data. Lower significance data that may be present from prior (32-bit data) operations is therefore preserved. Users not requiring this should clear ACCx during initialization.
- Use of the same W-reg for both indirect source (X or Y) and AWB indirect destination is not permitted if the source is a pre- or post-modified Effective Address.
- Stack must remain long word aligned. Consequently, [W15++] AWB is only permitted for use with long word MAC-class instructions.

I-Words: 1
Cycles: 1

Example:1 **MSC.L** **[W6]-=4, [W7]-=4, A, W7** **; Multiply [W6]*[W7] and subtract the result from ACCA ; W6 Post-decrement by 4 ; Post-decrement W7 by 4 ; CORCON = 0x0001 (integer multiply, no saturation)**

	Before Instruction	After Instruction
W6	4C00 0000	W6 4BFC 0000
W7	4800 0000	W7 48FC 0000
W8	0C00 0000	W8 0BFC 0000
ACCA	00 0567 8000 0000 0000	ACCA 00 3738 5ED0 0000 0000
Data	4C00 9051 0000	Data 4BFC D309 0000
Data	4800 7230 0000	Data 48FC 100B 0000
CORCON	0001	CORCON 0001

Instruction Descriptions (E to MULUU) (continued)

Example:1	MSC.L	[W6]-=4, [W7]- =4, A, W7	; Multiply [W6]*[W7] and subtract the result from ACCA ; W6 Post-decrement by 4 ; Post-decrement W7 by 4 ; CORCON = 0x0001 (integer multiply, no saturation)
-----------	-------	-----------------------------	--

SR	0000	SR	0000
----	------	----	------

Example:2	MSC.L	[W4+=12], [W5+w12], B, [W13]	; Multiply W4*W5 and subtract the result from ACCB ; Fetch [W11+W12] to W5 ; Write Back ACCA to W13 ; CORCON = 0x0000 (fractional multiply, no saturation)
-----------	-------	------------------------------------	--

Before Instruction		After Instruction	
W4	4000	W4	4000
W5	5000	W5	5000
W12	0800	W12	0800
W13	6233 1356	W13	3738 5ED0
ACCA	00 3738 5ED0 0000 0000	ACCA	00 3738 5ED0 0000 0000
ACCB	00 1000 0000 0000 0000	ACCB	00 0EC0 0000 0000 0000
Data	4800 0500 0000	Data	4800 0500 0000
Data	5800 2000 0000	Data	5800 2000 0000
CORCON	0000	CORCON	0000
SR	0000	SR	0000

MUL		Multiply f by Wn					
Syntax:	{label:}	MUL.b	f,	Wns			
		MUL{.w}					
		MUL.l					
Operands:		f ∈ [0 ... 64KB]; Wn ∈ [W0 ... W14]					
Operation:		If Byte mode: (Wn)[7:0] * (f)[7:0] → 16'b0, W2[15:0]. If Word mode: (Wn)[15:0] * (f)[15:0] → W2 If Long Word mode: (Wn) * (f) → W2					
Status Affected:		None					
Encoding:		1011	101L	ssss	ffff	ffff	ffff
						ffff	BU01
Description:		Unsigned integer multiply of Wn and the file register, then write the result to the default destination register W2. For long word operations, the LS 32-bits of the 64-bit result is written to W2. The 'L' and 'B' bits select operation data width. The 'f' bits select the address of the file register.					
I-Words:		1					
Cycles:		1					

MULISS/MULFSS	Signed-Signed Multiply to Accumulator								
Syntax:	{label:}	MULISS.w	Wb,	Ws,	A				
		MULFSS.w		[Ws],	B				
		MULISS.l		[Ws++],					
		MULFSS.l		[Ws--],					
				[++Ws],					
				[--Ws],					
Operands:	Wb ∈ [W0 ... W14]; Ws ∈ [W0 ... W15]								
Operation:	Signed (Wb) * signed (Ws) → ACC(A or B)[63:0] 8{ACC(A or B)[63]} → ACC(A or B)[71:64]								
Status Affected:	None								
Encoding:	1111	100L	www	ssss	pppA	UUUU	UUUU	I010	
Description:	<p>Performs word or long word integer (MULISS) or fractional (MULFSS) multiply of the signed contents of Wb and Ws. The source operands are interpreted as a two's-complement signed values. For MULISS.l, the 64-bit result will be sign-extended and written to ACCx[71:0].</p> <p>For MULFSS.l, the 64-bit result will be sign-extended, shifted left by one (to align the result and accumulator fractional points), and written to ACCx[71:0]. ACCx[0] will always be cleared.</p> <p>For MULISS.w, the 32-bit result will be sign-extended and written to ACCx[71:32]. ACCx[31:0] will hold the multiply result.</p> <p>For MULFSS.w, the 32-bit result will be sign-extended, shifted left by 33 bits (to align the result and accumulator fractional points), and written to ACCx[71:33]. ACCx[32:0] will always be cleared.</p> <p>The 'L' bit selects word or long word operation.</p> <p>The 'l' bit selects between integer and fractional operation.</p> <p>The 'A' bit selects the destination accumulator.</p> <p>The 's' bits select the source register.</p> <p>The 'w' bits select the base register.</p> <p>The 'p' bits select the source addressing mode.</p> <p>Note: The state of the Multiplier Mode bit (CORCON.US) has no effect upon the operation of this instruction.</p>								
I-Words:	1								
Cycles:	1								

MULISU/MULFSU	Signed-Unsigned Multiply to Accumulator								
Syntax:	{label:}	MULISU.w	Wb,	Ws,	A				
		MULFSU.w		[Ws],	B				
		MULISU.l		[Ws++],					
		MULFSU.l		[Ws--],					
				[++Ws],					
				[--Ws],					
Operands:		Wb ∈ [W0 ... W14]; Ws ∈ [W0 ... W15]							
Operation:		signed (Wb) * unsigned (Ws) → ACC(A or B)[63:0] 8{ACC(A or B)[63]} → ACC(A or B)[71:64]							
Status Affected:		None							
Encoding:		1111	101L	www	ssss	pppA	UUUU	UUUU	I110
Description:		<p>Performs a word or long word integer (MULISU) or fractional (MULFSU) multiply of the signed contents of Wb and unsigned contents of Ws. Wb is interpreted as a two's-complement signed value. For MULISU.l, the 64-bit result will be sign-extended and written to ACCx[71:0].</p> <p>For MULFSU.l, the 64-bit result will be sign-extended, shifted left by one (to align the result and accumulator fractional points), and written to ACCx[71:0]. ACCx[0] will always be cleared.</p> <p>For MULISU.w, the 32-bit result will be sign-extended and written to ACCx[71:32]. ACCx[31:0] will hold the multiply result.</p> <p>For MULFSU.w, the 32-bit result will be sign-extended, shifted left by 33 bits (to align the result and accumulator fractional points), and written to ACCx[71:33]. ACCx[32:0] will always be cleared.</p> <p>The 'L' bit selects word or long word operation.</p> <p>The 'l' bit selects between integer and fractional operation.</p> <p>The 'A' bit selects the destination accumulator.</p> <p>The 's' bits select the source register.</p> <p>The 'w' bits select the base register.</p> <p>The 'p' bits select the source addressing mode.</p> <p>Notes:</p> <ol style="list-style-type: none"> 1. The state of the Multiplier Mode bit (CORCON.US) has no effect upon the operation of this instruction. 2. An unsigned fractional operand includes one integer bit (i.e., can be up to 1.999...). Consequently, the mixed sign fractional result includes one integer bit (i.e., can be up to 1.999...). Results equal to, or in excess of, the range +/-1.0 may require normalization before subsequent use. 							
I-Words:		1							
Cycles:		1							

MULISU/MULIUU		Signed/Unsigned - Unsigned Literal Multiply to Accumulator							
Syntax:	{label:}	MULISU.w Ws,	lit8,	A					
		MULIUU.w [Ws],		B					
		MULISU.l [Ws++],							
		MULIUU.l [Ws--],							
		[++Ws],							
		[--Ws],							
Operands:		Ws ∈ [W0 ... W15]; lit8 ∈ [0 ... 255]							
Operation:		MULISU: signed (Ws) * unsigned lit8 → ACC(A or B)[63:0] 8{ACC(A or B)[63]} → ACC(A or B)[71:64] MULIUU: unsigned (Ws) * unsigned lit8 → ACC(A or B)[63:0] 8'b00 → ACC(A or B)[71:64] Note: The literal is zero-extended to the selected data size of the operation							
Status Affected:		None							
Encoding:		1111	111L	UUUU	ssss	pppA	kkkk	kkkk	1V10
Description:		<p>Performs a word or long word integer multiply of the signed (MULISU) or unsigned (MULIUU) contents of Ws and unsigned lit8. The 'V' bit is set to 1'b1 to select a signed Ws value and set to 1'b0 to select an unsigned Ws value.</p> <p>For MULISU.l, the 64-bit result will be sign-extended and written to ACCx[71:0].</p> <p>For MULIUU.l, the 64-bit result will be zero-extended and written to ACCx[71:0].</p> <p>For MULISU.w, the 32-bit result will be sign-extended and written to ACCx[71:32]. ACCx[31:0] will hold the multiply result.</p> <p>For MULIUU.w, the 32-bit result will be zero-extended and written to ACCx[71:32]. ACCx[31:0] will hold the multiply result.</p> <p>The 'L' bit selects word or long word operation.</p> <p>The 'V' bit selects between a signed or unsigned Ws value.</p> <p>The 'A' bit selects the destination accumulator.</p> <p>The 's' bits select the source register.</p> <p>The 'p' bits select the source addressing mode.</p> <p>The 'k' bits determine the 8-bit literal value.</p> <p>Notes:</p> <ol style="list-style-type: none"> 1. The state of the Multiplier Mode bit (CORCON.US) has no effect upon the operation of this instruction. 2. Fractional mode is not supported for these instructions. 							
I-Words:		1							
Cycles:		1							

MULIUU/MULFUU	Unsigned-Unsigned Multiply to Accumulator								
Syntax:	{label:}	MULIUU.w	Wb,	Ws,	A				
		MULFUU.w		[Ws],	B				
		MULIUU.l		[Ws++],					
		MULFUU.l		[Ws--],					
				[++Ws],					
				[--Ws],					
Operands:		Wb ∈ [W0 ... W14]; Ws ∈ [W0 ... W15]							
Operation:		unsigned (Wb) * unsigned (Ws) → ACC(A or B)[63:0] 8'h00 → ACC(A or B)[71:64]							
Status Affected:		None							
Encoding:		1111	101L	www	sss	pppA	UUUU	UUUU	I010
Description:		<p>Performs a word or long word integer (MULIUU) or fractional (MULFUU) multiply of the unsigned contents of Wb and unsigned contents of Ws (see Note 2).</p> <p>For MULIUU.l, the 64-bit result will be zero-extended and written to ACCx[71:0].</p> <p>For MULFUU.l, the 64-bit result will be zero-extended, shifted left by one (to align the result and accumulator fractional points), and written to ACCx[71:0]. ACCx[0] will always be cleared.</p> <p>For MULIUU.w, the 32-bit result will be zero-extended and written to ACCx[71:32]. ACCx[31:0] will hold the multiply result.</p> <p>For MULFUU.w, the 32-bit result will be zero-extended, shifted left by 33 bits (to align the result and accumulator fractional points) and written to ACCx[71:33]. ACCx[32:0] will always be cleared.</p> <p>The 'L' bit selects word or long word operation.</p> <p>The 'l' bit selects between integer and fractional operation.</p> <p>The 'A' bit selects the destination accumulator.</p> <p>The 's' bits select the source register.</p> <p>The 'w' bits select the base register.</p> <p>The 'p' bits select the source addressing mode.</p> <p>Notes:</p> <ol style="list-style-type: none"> 1. The state of the Multiplier Mode bit (CORCON.US) has no effect upon the operation of this instruction. 2. An unsigned fractional operand includes one integer bit (i.e., can be up to 1.999...). Consequently, the unsigned fractional result includes two integer bits (i.e., can be up to 3.999...). Results greater than or equal to 1.0 may require normalization before subsequent use. 							
I-Words:		1							
Cycles:		1							

MULIUS/MULFUS	Unsigned-Signed Multiply to Accumulator								
Syntax:	{label:}	MULIUS.w	Wb,	Ws,	A				
		MULFUS.w		[Ws],	B				
		MULIUS.l		[Ws++],					
		MULFUS.l		[Ws--],					
				[++Ws],					
				[--Ws],					
Operands:		Wb ∈ [W0 ... W14]; Ws ∈ [W0 ... W15]							
Operation:		unsigned (Wb) * signed (Ws) → ACC(A or B)[63:0] 8{ACC(A or B)[63]} → ACC(A or B)[71:64]							
Status Affected:		None							
Encoding:		1111	100L	www	ssss	pppA	UUUU	UUUU	I110
Description:		<p>Performs a word or long word integer (MULIUS) or fractional (MULFUS) multiply of the unsigned contents of Wb and signed contents of Ws (see Note 2).</p> <p>For MULIUS.l, the 64-bit result will be sign-extended and written to ACCx[71:0].</p> <p>For MULFUS.l, the 64-bit result will be sign-extended, shifted left by one (to align the result and accumulator fractional points), and written to ACCx[71:0]. ACCx[0] will always be cleared.</p> <p>For MULIUS.w, the 32-bit result will be sign-extended and written to ACCx[71:32]. ACCx[31:0] will hold the multiply result.</p> <p>For MULFUS.w, the 32-bit result will be sign-extended, shifted left by 33 bits (to align the result and accumulator fractional points), and written to ACCx[71:33]. ACCx[32:0] will always be cleared.</p> <p>The 'L' bit selects word or long word operation.</p> <p>The 'l' bit selects between integer and fractional operation.</p> <p>The 'A' bit selects the destination accumulator.</p> <p>The 's' bits select the source register.</p> <p>The 'w' bits select the base register.</p> <p>The 'p' bits select the source addressing mode.</p> <p>Notes:</p> <ol style="list-style-type: none"> 1. The state of the Multiplier Mode bit (CORCON.US) has no effect upon the operation of this instruction. 2. An unsigned fractional operand includes one integer bit (i.e., can be up to 1.999...). Consequently, the mixed sign fractional result includes one integer bit (i.e., can be up to 1.999...). Results equal to, or in excess of, the range +/-1.0 may require normalization before subsequent use. 							
I-Words:		1							
Cycles:		1							

MULISS/MULIUS		Signed/Unsigned-Signed Literal Multiply to Accumulator					
Syntax:	{label:}	MULISS.w Ws,	slit8,	A			
		MULIUS.w [Ws],		B			
		MULISS.l [Ws++],					
		MULIUS.l [Ws--],					
		[++Ws],					
		[--Ws],					
Operands:		Ws ∈ [W0 ... W15]; slit8 ∈ [-128 ... 127]					
Operation:		MULxUS : unsigned (Ws) * signed slit8 → ACC(A or B)[63:0] MULxSS : signed (Ws) * signed slit8 → ACC(A or B)[63:0] 8{ACC(A or B)[63]} → ACC(A or B)[71:64]					
		Note: The literal is sign-extended to the selected data size of the operation					
Status Affected:		None					
Encoding:		1111	110L	UUUU	ssss	pppA	kkkk kkkk 1V10
Description:		<p>Performs a word or long word integer multiply of the signed (MULISS) or unsigned (MULIUS) contents of Ws and signed slit8. The 'V' bit is set to 1'b1 to select a signed Ws value and set to 1'b0 to select an unsigned Ws value.</p> <p>For MULISS.l, the 64-bit result will be sign-extended and written to ACCx[71:0].</p> <p>For MULIUS.l, the 64-bit result will be sign-extended and written to ACCx[71:0].</p> <p>For MULISS.w, the 32-bit result will be sign-extended and written to ACCx[71:32]. ACCx[31:0] will hold the multiply result.</p> <p>For MULIUS.w, the 32-bit result will be sign-extended and written to ACCx[71:32]. ACCx[31:0] will hold the multiply result.</p> <p>The 'L' bit selects word or long word operation.</p> <p>The 'V' bit selects between a signed or unsigned Ws value.</p> <p>The 'A' bit selects the destination accumulator.</p> <p>The 's' bits select the source register.</p> <p>The 'p' bits select the source addressing mode.</p> <p>The 'k' bits determine the 8-bit literal value.</p> <p>Notes:</p> <ol style="list-style-type: none"> 1. The state of the Multiplier Mode bit (CORCON.US) has no effect upon the operation of this instruction. 2. Fractional mode is not supported for these instructions. 					
I-Words:		1					
Cycles:		1					

MULSS/MULUS	Signed/Unsigned-Signed Literal Integer Multiply
Syntax:	{label:} MULSS.d Ws, slit8, Wnd MULSS.l [Ws], MULSS.w [Ws++], MULUS.d [Ws--], MULUS.l [++Ws], MULUS.w [--Ws],
Operands:	Ws ∈ [W0 ... W15]; slit8 ∈ [-128 ... 127]; Wnd ∈ [W0 ... W14]
Operation:	MULSS.d : signed (Ws) * signed slit8 → {Wnd+1[31:0], Wnd[31:0]} MULSS.l : signed (Ws) * signed slit8 → {Wnd[31:0]} MULSS.w : signed (Ws[15:0]) * signed slit8 → {Wnd[31:0]} MULUS.d : unsigned (Ws) * signed slit8 → {Wnd+1[31:0], Wnd[31:0]} MULUS.l : unsigned (Ws) * signed slit8 → {Wnd[31:0]} MULUS.w : unsigned (Ws[15:0]) * signed slit8 → {Wnd[31:0]} Note: The literal is sign-extended to the selected data size of the operation
Status Affected:	None
Encoding:	1111 010L dddd ssss pppE kkkk kkkk 0V10
Description:	Performs a 32-bit x 32-bit or a 16-bit x 16-bit integer multiply of the signed or unsigned contents of Ws and sign-extended slit8. The 'V' bit is set to 1'b1 to select a signed Ws value and set to 1'b0 to select an unsigned Ws value. For MULSS.d and MULUS.d (L = 1, E = 1), a 32-bit x 32-bit multiply of Ws and sign-extended slit8 is executed. The MS 32-bits of the 64-bit result will be written to Wnd+1, and the LS 32-bits of the result will be written to Wnd. For MULSS.l and MULUS.l (L = 1, E = 0), a 32-bit x 32-bit multiply of Ws and sign-extended slit8 is executed. The LS 32-bits of the 64-bit result will be written to Wnd. For MULSS.w and MULUS.w (L = 0, E = 0), a 16-bit x 16-bit multiply of the lsw of Ws and sign-extended slit8 is executed. The result will be 32-bits and is written to Wnd. The 'L' bit selects the operand data size. The 'V' bit selects between a signed or unsigned Ws value. The 'E' bit selects between a 32-bit and 64-bit result write. The 's' bits select the source register. The 'd' bits select the destination register. The 'p' bits select the source addressing mode. The 'k' bits determine the 8-bit literal value. Notes: 1. The state of the Multiplier Mode bit (CORCON.US) has no effect upon the operation of this instruction. 2. For 32-bit result writes, user is responsible to ensure that the result does not overflow into the sign bit, Wnd[31].
I-Words:	1
Cycles:	1

MULSS		Signed-Signed Integer Multiply							
Syntax:	{label:}	MULSS.d	Wb,	Ws,	Wnd				
		MULSS.l		[Ws],					
		MULSS.w		[Ws++],					
				[Ws--],					
				[++Ws],					
				[--Ws],					
Operands:		Wb ∈ [W0 ... W15]; Ws ∈ [W0 ... W15]; Wnd ∈ [W0 ... W14]							
Operation:		MULSS.d : signed (Wb) * signed (Ws) → {Wnd+1[31:0], Wnd[31:0]}							
		MULSS.l : signed (Wb) * signed (Ws) → {Wnd[31:0]}							
		MULSS.w : signed (Wb[15:0]) * signed (Ws[15:0]) → {Wnd[31:0]}							
Status Affected:		None							
Encoding:		s001	010L	dddd	ssss	pppE	UUww	wwUU	0000
Description:		<p>Performs a 16-bit x 16-bit or 32-bit x 32-bit integer multiply of the signed contents of Wb and Ws. For MULSS.d (L=1, E=1), a 32-bit x 32-bit multiply of Wb and Ws is executed. The MS 32-bits of the 64-bit result will be written to Wnd+1, and the LS 32-bits of the result will be written to Wnd.</p> <p>For MULSS.l (L=1, E=0), a 32-bit x 32-bit multiply of Wb and Ws is executed. The LS 32-bits of the 64-bit result will be written to Wnd.</p> <p>For MULSS.w (L=0, E=0), a 16-bit x 16-bit multiply of the lsw of Wb and the lsw of Ws is executed. The result will be 32-bits and is written to Wnd.</p> <p>Both source operands are interpreted as two's-complement integer signed values.</p> <p>The 'S' bit selects instruction size.</p> <p>The 'L' bit selects the operand data size.</p> <p>The 'E' bit selects between a 32-bit and 64-bit result write.</p> <p>The 's' bits select the source register.</p> <p>The 'w' bits select the base register.</p> <p>The 'd' bits select the destination register.</p> <p>The 'p' bits select the source addressing mode.</p> <p>Notes:</p> <ol style="list-style-type: none"> 1. The state of the Multiplier Mode bit (CORCON.US) has no effect upon the operation of this instruction. 2. For 32-bit result writes, user is responsible to ensure that the result does not overflow into the sign bit, Wnd[31]. 							
I-Words:		1 or 0.5							
Cycles:		1							

MULSU		Signed-Unsigned Integer Multiply							
Syntax:	{label:}	MULSU.d	Wb,	Ws,	Wnd				
		MULSU.l		[Ws],					
		MULSU.w		[Ws++],					
				[Ws--],					
				[++Ws],					
				[--Ws],					
Operands:		Wb ∈ [W0 ... W15]; Ws ∈ [W0 ... W15]; Wnd ∈ [W0 ... W14]							
Operation:		MULSU.d : signed (Wb) * unsigned (Ws) → {Wnd+1[31:0], Wnd[31:0]}							
		MULSU.l : signed (Wb) * unsigned (Ws) → {Wnd[31:0]}							
		MULSU.w : signed (Wb[15:0]) * unsigned (Ws[15:0]) → {Wnd[31:0]}							
Status Affected:		None							
Encoding:		1001	011L	dddd	ssss	pppE	UUww	wwUU	0100
Description:		<p>Performs a 16-bit x 16-bit or 32-bit x 32-bit integer multiply of the signed contents of Wb and unsigned contents of Ws. Wb is interpreted as a two's-complement signed value.</p> <p>For MULSU.d (L = 1, E = 1), a 32-bit x 32-bit multiply of Wb and Ws is executed. The MS 32-bits of the 64-bit result will be written to Wnd+1, and the LS 32-bits of the result will be written to Wnd.</p> <p>For MULSU.l (L=1, E = 0), a 32-bit x 32-bit multiply of Wb and Ws is executed. The LS 32-bits of the result will be written to Wnd.</p> <p>For MULSU.w (L=0, E = 0), a 16-bit x 16-bit multiply of the lsw of Wb and the lsw of Ws is executed. The result will be 32-bits and is written to Wnd.</p> <p>The 'L' bit selects the operand data size.</p> <p>The 'E' bit selects between a 32-bit and 64-bit result write.</p> <p>The 's' bits select the source register.</p> <p>The 'w' bits select the base register.</p> <p>The 'd' bits select the destination register.</p> <p>The 'p' bits select the source addressing mode.</p> <p>Notes:</p> <ol style="list-style-type: none"> 1. The state of the Multiplier Mode bit (CORCON.US in CORCON) has no effect upon the operation of this instruction. 2. For 32-bit result writes, user is responsible to ensure that the result does not overflow into the sign bit, Wnd[31]. 							
I-Words:		1							
Cycles:		1							

Example 1: MUL.SU W8, [W9], W0 ; Multiply W8*[W9] ; Store the result to W0:W1

	Before Instruction	After Instruction
W0	68DC	W0 0000
W1	AA40	W1 F100
W8	F000	W8 F000
W9	178C	W9 178C
Data	178C F000	Data 178C F000
SR	0000	SR 0000

Example 2: MUL.SU W2, [++W3], W4 ; Pre-Increment W3 ; Multiply W2*[W3] ; Store the result to W4:W5

	Before Instruction	After Instruction
W2	0040	W2 0040
W3	0280	W3 0282

Instruction Descriptions (E to MULUU) (continued)

Example 2: `MUL.SU W2, [++W3], W4 ; Pre-Increment W3 ; Multiply W2*[W3] ; Store the result to W4:W5`

W4	1819	W4	1A00
W5	2021	W5	0000
Data 0282	0068	Data 0282	0068
SR	0000	SR	0000

MULSU/MULUU		Signed/Unsigned-Unsigned Short Literal Integer Multiply							
Syntax:	{label:}	MULSU.d	Ws,	lit8,	Wnd				
		MULSU.l	[Ws],						
		MULSU.w	[Ws++],						
		MULUU.d	[Ws-],						
		MULUU.l	[++Ws],						
		MULUU.w	--Ws],						
Operands:		Ws ∈ [W0 ... W15]; lit8 ∈ [0...255]; Wnd ∈ [W0 ... W14]							
Operation:		MULSU.d : signed (Ws) * unsigned lit8 → {Wnd+1[31:0], Wnd[31:0]}							
		MULSU.l : signed (Ws) * unsigned lit8 → {Wnd[31:0]}							
		MULSU.w : signed (Ws[15:0]) * unsigned lit8 → {Wnd[31:0]}							
		MULUU.d : unsigned (Ws) * unsigned lit8 → {Wnd+1[31:0], Wnd[31:0]}							
		MULUU.l : unsigned (Ws) * unsigned lit8 → {Wnd[31:0]}							
		MULUU.w : unsigned (Ws[15:0]) * unsigned lit8 → {Wnd[31:0]}							
		Note: The literal is zero-extended to the selected data size of the operation							
Status Affected:		None							
Encoding:		1111	011L	dddd	ssss	pppE	kkkk	kkkk	0V10
Description:		<p>Performs a 16-bit x 16-bit or 32-bit x 32-bit integer multiply of the signed or unsigned contents of Ws and unsigned lit8. The 'V' bit is set to 1'b1 to select a signed Ws value and set to 1'b0 to select an unsigned Ws value.</p> <p>For MULSU.d and MULUU.d (L = 1, E = 1), a 32-bit x 32-bit multiply of Ws and zero-extended lit8 is executed. The MS 32-bits of the 64-bit result will be written to Wnd+1, and the LS 32-bits of the result will be written to Wnd.</p> <p>For MULSU.l and MULUU.l (L = 1, E = 0), a 32-bit x 32-bit multiply of Ws and zero-extended lit8 is executed. The LS 32-bits of the 64-bit result will be written to Wnd.</p> <p>For MULSU.w and MULUU.w (L = 0, E = 0), a 16-bit x 16-bit multiply of the lsw of Ws and zero-extended lit8 is executed. The result will be 32-bits and is written to Wnd.</p> <p>The 'L' bit selects the operand data size.</p> <p>The 'V' bit selects between a signed or unsigned Ws value.</p> <p>The 'E' bit selects between a 32-bit and 64-bit result write.</p> <p>The 's' bits select the source register.</p> <p>The 'd' bits select the destination register.</p> <p>The 'p' bits select the source addressing mode.</p> <p>The 'k' bits determine the 8-bit literal value.</p> <p>Notes:</p> <ol style="list-style-type: none"> 1. The state of the Multiplier Mode bit (CORCON.US) has no effect upon the operation of this instruction. 2. For signed 32-bit result writes, user is responsible to ensure that the result does not overflow into the sign bit, Wnd[31]. 							
I-Words:		1							
Cycles:		1							

MULUS	Unsigned-Signed Integer Multiply								
Syntax:	{label:}	MULUS.d	Wb,	Ws,	Wnd				
		MULUS.l		[Ws],					
		MULUS.w		[Ws++],					
				[Ws--],					
				[++Ws],					
				[--Ws],					
Operands:	Wb ∈ [W0 ... W15]; Ws ∈ [W0 ... W15]; Wnd ∈ [W0 ... W14]								
Operation:	MULUS.d : unsigned (Wb) * signed (Ws) → {Wnd+1[31:0], Wnd[31:0]}								
	MULUS.l : unsigned (Wb) * signed (Ws) → {Wnd[31:0]}								
	MULUS.w : unsigned (Wb[15:0]) * signed (Ws[15:0]) → {Wnd[31:0]}								
Status Affected:	None								
Encoding:	1001	010L	dddd	ssss	pppE	UUww	wwUU	0100	
Description:	<p>Performs a 16-bit x 16-bit or 32-bit x 32-bit integer multiply of the unsigned contents of Wb and signed contents of Ws. Ws is interpreted as a two's-complement signed value.</p> <p>For MULUS.d (L = 1, E = 1), a 32-bit x 32-bit multiply of Wb and Ws is executed. The MS 32-bits of the 64-bit result will be written to Wnd+1, and the LS 32-bits of the result will be written to Wnd.</p> <p>For MULUS.l (L=1, E = 0), a 32-bit x 32-bit multiply of Wb and Ws is executed. The LS 32-bits of the result will be written to Wnd.</p> <p>For MULUS.w (L=0, E = 0), a 16-bit x 16-bit multiply of the lsw of Wb and the lsw of Ws is executed. The result will be 32-bits and is written to Wnd.</p> <p>The 'L' bit selects the operand data size.</p> <p>The 'E' bit selects between a 32-bit and 64-bit result write.</p> <p>The 's' bits select the source register.</p> <p>The 'w' bits select the base register.</p> <p>The 'd' bits select the destination register.</p> <p>The 'p' bits select the source addressing mode.</p> <p>Notes:</p> <ol style="list-style-type: none"> 1. The state of the Multiplier Mode bit (CORCON.US) has no effect upon the operation of this instruction. 2. For 32-bit result writes, user is responsible to ensure that the result does not overflow into the sign bit, Wnd[31]. 								
I-Words:	1								
Cycles:	1								

MULUU		Unsigned-Unsigned Integer Multiply							
Syntax:	{label:}	MULUU.d	Wb,	Ws,	Wnd				
		MULUU.l		[Ws],					
		MULUU.w		[Ws++],					
				[Ws--],					
				[++Ws],					
				[--Ws],					
Operands:		Wb ∈ [W0 ... W15]; Ws ∈ [W0 ... W15]; Wnd ∈ [W0 ... W14]							
Operation:		MULUU.d : unsigned (Wb) * unsigned (Ws) → {Wnd+1[31:0], Wnd[31:0]}							
		MULUU.l : unsigned (Wb) * unsigned (Ws) → {Wnd[31:0]}							
		MULUU.w : unsigned (Wb[15:0]) * unsigned (Ws[15:0]) → {Wnd[31:0]}							
Status Affected:		None							
Encoding:		s001	011L	dddd	ssss	pppE	UUww	wwUU	0000
Description:		<p>Performs a 16-bit x 16-bit or 32-bit x 32-bit integer multiply of the unsigned contents of Wb and Ws. For MULUU.d (L = 1, E = 1), a 32-bit x 32-bit multiply of Wb and Ws is executed. The MS 32-bits of the 64-bit result will be written to Wnd+1, and the LS 32-bits of the result will be written to Wnd.</p> <p>For MULUU.l (L=1, E = 0), a 32-bit x 32-bit multiply of Wb and Ws is executed. The LS 32-bits of the result will be written to Wnd.</p> <p>For MULUU.w (L=0, E = 0), a 16-bit x 16-bit multiply of the lsw of Wb and the lsw of Ws is executed. The result will be 32-bits and is written to Wnd.</p> <p>The 'S' bit selects instruction size.</p> <p>The 'L' bit selects the operand data size.</p> <p>The 'E' bit selects between a 32-bit and 64-bit result write.</p> <p>The 's' bits select the source register.</p> <p>The 'w' bits select the base register.</p> <p>The 'd' bits select the destination register.</p> <p>The 'p' bits select the source addressing mode.</p> <p>Note:</p> <ol style="list-style-type: none"> The state of the Multiplier Mode bit (CORCON.US) has no effect upon the operation of this instruction. 							
I-Words:		1 or 0.5							
Cycles:		1							

4.7. Instruction Descriptions (N to XORWF)

NEG		Negate Accumulators			
Syntax:	{label:}	NEG	A	B	
Operands:	None				
Operation:	if (NEGAB A) then -ACCA → ACCA if (NEGAB B) then -ACCB → ACCB				
Status Affected:	OA, SA or OB, SB				
Encoding:	0111	001A	UUUU	1010	
Description:	Compute the 2's complement of the contents of the specified accumulator and place the result back into the specified accumulator. The 'A' bit specifies the selected accumulator. OA and SA are affected if AccA is selected. OB and SB are affected if AccB is selected.				
I-Words:	0.5				
Cycles:	1				

Example:1	NEG	A	;Negate the value of ACCA and store the results back in ACCA.	
			Before execution	After execution
			ACCA	ACCA
			0x00_4000_0000_000_0000	0xFF_C000_0000_000_0000

Example 1:	NEG A ; Negate ACCA ; Store result to ACCA ; CORCON = 0x0000 (no saturation)			
		Before Instruction		After Instruction
	ACCA	00 3290 59C8	ACCA	FF CD6F A638
	CORCON	0000	CORCON	0000
	SR	0000	SR	0000

Example 2:	NEG B ; Negate ACCB ; Store result to ACCB ; CORCON = 0x00C0 (normal saturation)			
		Before Instruction		After Instruction
	ACCB	FF F230 10DC	ACCB	00 0DCF EF24
	CORCON	00C0	CORCON	00C0
	SR	0000	SR	0000

NEG		Negate f				
Syntax:	{label:}	NEG.b	f	{Wnd}	{WREG}	
		NEG.bz				
		NEG{.w}				
		NEG.l				
Operands:		f ∈ [0 ... 64KB]; Wnd ∈ [W0 ... W14]				
Operation:		(f) + 1 → destination designated by D				
Status Affected:		C, N, OV, Z				
Encoding:		1101	101L	dddd	ffff	ffff ffff ffff BD01
Description:		Compute the 2's complement of the contents of the file register and place the result in the destination designated by D. If the optional Wnd is specified, D=0 and store result in Wnd; otherwise, D=1 and store result in the file register. The 'L' and 'B' bits select operation data width. The 'D' bit selects the destination. The 'f' bits select the address of the file register. The 'd' bits select the Working register.				
I-Words:		1				
Cycles:		1				

Example 1: `NEG.B 0x880, WREG ; Negate (0x880) (Byte mode) ; Store result to WREG`

	Before Instruction		After Instruction		
WREG (W0)	9080		WREG (W0)	90AB	
Data 0880	2355		Data 0880	2355	
SR	0000		SR	0008	(N = 1)

Example 2: `NEG 0x1200 ; Negate (0x1200) (Word mode)`

	Before Instruction		After Instruction	
Data 1200	8923		Data 1200	76DD
SR	0000		SR	0000

NEOP		None Executable No Operation			
Syntax:	{label;} NEOP				
Operands:	None				
Operation:	No Operation				
Status Affected:	None				
Encoding:	0000 0000 UUUU UUUU				
Description:	No Operation is performed. This instruction will also consume no execution time. It can be regarded as a means to pad a 16-bit instruction (to use a 32-bit word) when the instruction cannot be paired with another 16-bit instruction (to maintain alignment).				
I-Words:	0.5				
Cycles:	0				

NOP		No Operation			
Syntax:	{label;} NOP				
Operands:	None				
Operation:	No Operation				
Status Affected:	None				
Encoding:	0000	0001	UUUU	UUUU	
Description:	No Operation is performed.				
I-Words:	1				
Cycles:	1				

Example 1: NOP ; execute no operation

Before Instruction		After Instruction	
PC	00 1092	PC	00 1094
SR	0000	SR	0000

Example 2: NOP ; execute no operation

Before Instruction		After Instruction	
PC	00 08AE	PC	00 08B0
SR	0000	SR	0000

NOPR		No Operation (32-bit)						
Syntax:	{label;} NOPR							
Operands:	None							
Operation:	No Operation							
Status Affected:	None							
Encoding:	1111 1110 0000 0000 0000 0000 0000 0011							
Description:	No Operation is performed.							
I-Words:	1							
Cycles:	1							

Example 1: NOPR ; execute no operation

Before Instruction		After Instruction	
PC	00 2430	PC	00 2432
SR	0000	SR	0000

Example 2: NOPR ; execute no operation

Before Instruction		After Instruction	
PC	00 1466	PC	00 1468
SR	0000	SR	0000

NORM		Normalize Accumulator							
Syntax:	{label:}	NORM{.w} A,		Wd					
		NORM.l B,		[Wd]					
				[Wd++]					
				[Wd--]					
				[++Wd]					
				[--Wd]					
				[Wd+Wb]					
Operands:		Wd ∈ [W0 ... W15], Wb ∈ [W0 ... W15]							
Operation:		refer to text							
Status Affected:		OA or OB, N, Z							
Encoding:		1100	10AL	www	ddd	UUUq	qqUU	UUUU	1111
Description:		<p>Normalize the contents of the target accumulator. If the accumulator contains an overflowed value, the contents of the accumulator are shifted right by the minimum number of bits required to remove the overflow. If the accumulator does not contain an overflowed value, the contents of the accumulator are shifted left by the minimum number of bits required to produce the largest fractional data value without an overflow.</p> <p>If it is not possible to normalize the target accumulator (i.e., it is already normalized, or it is all 0's or all 1's) Wd is cleared and the Z bit is set (and the N bit is cleared). The target accumulator is unaffected.</p> <p>If it is possible to normalize the target accumulator, the exponent (shift value) required to normalize the target accumulator is written into Wd. A positive result indicates that a right shift of the accumulator was required for normalization. A negative result indicates that a left shift of the accumulator was required for normalization. The N bit is set to reflect the sign of the result and the Z bit is cleared.</p> <p>The 'L' bit selects word or long word Wd destination.</p> <p>The 'A' bit specifies the destination accumulator.</p> <p>The 'd' bits select the destination register.</p> <p>The 'q' bits select the destination addressing mode.</p> <p>The 'w' bits define the offset Wb.</p> <p>Note:</p> <ol style="list-style-type: none"> 1. <p>OA or OB status bits are set based on the content of the target accumulator. Consequently, because NORM removes any overflow, OA or OB will always be cleared.</p> <p>SA/SB are 'sticky' so will remain set if set prior to execution of the NORM, but they can never be affected by this instruction.</p>							
I-Words:		1							
Cycles:		1							

POP	Pop Top of Return Stack								
Syntax:	{label:}	POP.I	f						
Operands:	f ∈ [0 ... 1MB]								
Operation:	(W15) - 4 → W15; (TOS) → (f,2'b00)								
Status Affected:	None								
Encoding:	1011	1101	ffff	ffff	ffff	ffff	ffff	ffff	UU01
Description:	The Stack Pointer (W15) is pre-decremented and Top-of-Stack (TOS) value is pulled off the stack and written to the file register. The 'f' bits select the address of the file register.								
	Notes:								
	1. This instruction operates in Long Word mode only. The LS 2-bits of the file address will therefore always be 2'b00.								
	2. Accessible file address space is 1MB.								
I-Words:	1								
Cycles:	1								

POP	Pop Working (W) Register			
Syntax:	{label:}	POP.L	Wnd	
Operands:	Wnd ∈ [W0 ... W15]			
Operation:	POP.L ^{1,2} ; (W15) - 4 → W15; (TOS) → Wnd			
Status Affected:	None			
Encoding:	0001	110L	dddd	ssss
Description:	<p>Move the top of a LIFO stack data structure (or data memory) to the destination Working register, Wnd. Use of the system Stack Pointer ([-W15]) is implied for POP.L.</p> <p>The 'L' bit selects operation data width.</p> <p>The 's' bits select the Working Source register.</p> <p>The 'd' bits select the Working Destination register.</p>			
I-Words:	0.5			
Cycles:	1			

Notes:

1. This instruction operates in Long Word mode only. The LS 2-bits of the file address will therefore always be 2'b00.
2. Accessible file address space is 1MB.

PUSH		Push Top of Return Stack (TOS)					
Syntax:	{label:}	PUSH.I	f				
Operands:	f ∈ [0 ... 1MB]						
Operation:	(f) → (TOS); (W15)+4 → W15						
Status Affected:	None						
Encoding:	1011	1111	ffff	ffff	ffff	ffff	UU01
Description:	The file register contents are written to the Top of Stack (TOS) location. The Stack Pointer (W15) is then incremented. The 'f' bits select the address of the file register.						
	Notes:						
	1. This instruction operates in Long Word mode only. The LS 2-bits of the file address will therefore always be 2'b00.						
	2. Accessible file address space is 1MB.						
I-Words:	1						
Cycles:	1						

Example 1: PUSH 0x2004 ; Push (0x2004) to TOS

Before Instruction		After Instruction	
W15	0B00	W15	0B02
Data 0B00	791C	Data 0B00	D400
Data 2004	D400	Data 2004	D400
SR	0000	SR	0000

Example 2: PUSH 0xC0E ; Push (0xC0E) to TOS

Before Instruction		After Instruction	
W15	0920	W15	0922
Data 0920	0000	Data 0920	67AA
Data 0C0E	67AA	Data 2004	67AA
SR	0000	SR	0000

PUSH		Push Working (W) Register			
Syntax:	{label:}	PUSH.I	Wns		
Operands:	Wns ∈ [W0 ... W15];				
Operation:	PUSH.I ^{1,2} : Wns → (TOS); (W15)+4 → W15				
Status Affected:	None				
Encoding:	0001	111L	dddd	ssss	
Description:	<p>Move the contents of the source Working register, Wns, to the top of a LIFO stack data structure (or data memory). Use of the system Stack Pointer ([W15++]) is implied for PUSH.I.</p> <p>The 'L' bit selects operation data width.</p> <p>The 's' bits select the Working Source register.</p> <p>The 'd' bits select the Working Destination register.</p>				
I-Words:	0.5				
Cycles:	1				

Notes:

1. PUSH.I Wns is functionally equivalent to MOV.I Wns, [W15++].
2. In order to preserve system stack Long Word alignment, the PUSH mnemonic only supports Long Word mode, and even the MOV.w mnemonic does not permit use of W15 as destination.

RCALL Relative Call

Syntax: {label;} RCALL Label

Operands: Label is resolved by the linker to a signed word offset (slit20)

Operation: (PC) + 4 → PC,
 (8'b0, PC[23:2]) → TOS[31:2]; 2'b00 → TOS[1:0],
 (W15) + 4 → W15,
 PC+ 2*slit20 → PC;
 NOP → Instruction Register

Status Affected: None

Encoding: 1101 010U nnnn nnnn nnnn nnnn nnnn 0010

Description: Subroutine call with a forward or backward branch address range of 1MB to either a 32-bit or 16-bit instruction.
 The long word aligned return address (PC+4) is pushed onto the system stack. The 2's complement byte offset value '2*slit20' (the PC offset) is added to the PC. Since the PC will have incremented to fetch the next instruction, the new address will be (PC+4) + 2*slit20.
 The 'n' bits are a signed literal that specifies the number of PS words to branch from (PC+4).

I-Words: 1

Cycles: 1

```

Example 1:   012004 RCALL _Task1                                                 ; Call _Task1; _Task1
               012006 ADD W0, W1, W2                                             subroutine
               . . . . .
               012458 _Task1: SUB W0, W2, W3
               01245A . . .
    
```

	Before Instruction		After Instruction	
PC	01 2004	PC	01 2458	
W15	0810	W15	0814	
Data 0810	FFFF	Data 0810	2006	
Data 0812	FFFF	Data 0812	0001	
SR	0000	SR	0000	

```

Example 2:   00620E RCALL _Init006210 MOV W0, [W4+                             ; Call _Init; _Init subroutine
               +] . . . . .007000 _Init: CLR W2007002 . . .
    
```

	Before Instruction		After Instruction	
PC	00 620E	PC	00 7000	
W15	0C50	W15	0C54	
Data 0C50	FFFF	Data 0C50	6210	
Data 0C52	FFFF	Data 0C52	0000	
SR	0000	SR	0000	

RCALL	Computed Call								
Syntax:	{label:}	RCALL	Wns						
Operands:	Wns \in [W0 ... W15]								
Operation:	(PC) + 4 \rightarrow PC, (8'b0, PC[23:0]) \rightarrow TOS[31:0], (W15) + 4 \rightarrow W15, (PC) + 2*Wns[19:0] \rightarrow PC; NOP \rightarrow Instruction Register								
Status Affected:	None								
Encoding:	1101	011U	UUUU	ssss	UUUU	UUUU	UUUU	0110	
Description:	<p>Computed subroutine call with a forward or backward branch address range of 1MB to any size of instruction.</p> <p>The long word aligned return address (PC+4) is pushed onto the system stack. The signed value in Wns[19:0] represents the PS (16-bit) word offset from the current PC. This value is multiplied by 2 to create a byte address which is then added to the contents of the PC to form the target address. Wn must therefore contain a signed value that specifies the number of PS words to offset from (PC+4) for the call.</p> <p>RCALLW is a two-cycle instruction.</p> <p>The 's' bits specify the source register.</p> <p>Note: If Wns[31:19] is not all 0's or all 1's, an address error trap will be initiated.</p>								
I-Words:	1								
Cycles:	2								
	<p>Note: The call target instruction fetch is not executed if an exception is pending, making effective instruction execution time one cycle.</p>								

REPEAT	Repeat next instruction, literal count						
Syntax:	{label:}	REPEAT	lit20				
Operands:	lit20 ∈ [0 ... 1048575]						
Operation:	(12'h000, lit20) → RCOUNT[31:0] (Loop Count Register) (PC) + 4 → PC 1 → RA (Enable Code Looping)						
Status Affected:	RA (if lit20 > 0)						
Encoding:	1101	010U	kkkk	kkkk	kkkk	kkkk	0110
Description:	<p>The instruction immediately following the REPEAT instruction is executed (lit20+1) times. The repeated instruction is held in the instruction register for all iterations and so is fetched only once (during the REPEAT instruction, as would be expected). The last iteration of the repeated instruction fetches the next instruction.</p> <p>The repeat count is decremented during each iteration. When it equals zero (during the penultimate loop), PC increment and instruction fetch is re-enabled (RA=0) allowing the final iteration to fetch the next instruction and normal execution continues.</p> <p>The repeated instruction can be interrupted before any iteration by any interrupt. Note that the user must save and restore RCOUNT to support nested repeats (e.g., from within the interrupt service routine).</p> <p>The 'k' bits are an unsigned literal that specifies the loop count.</p> <p>Note:</p> <ol style="list-style-type: none"> If lit20 = 0, RA is not set and the subsequent instruction executes as normal (equivalent to a loop count of one). 						
I-Words:	1						
Cycles:	1						

REPEAT	Repeat next instruction, short literal count		
Syntax:	{label:}	REPEAT	lit5
Operands:	lit5 ∈ [0 ... 31]		
Operation:	(27'h000000, lit5) → RCOUNT[31:0] (Loop Count Register) (PC) + 2 → PC 1 → RA (Enable Code Looping)		
Status Affected:	RA (if lit5 > 0)		
Encoding:	0111	001k	kkkk 1111
Description:	<p>The instruction immediately following the REPEAT instruction is executed (lit5+1) times. If lit5 > 31, assemble as REPEAT instruction.</p> <p>The repeated instruction is held in the instruction register for all iterations and so is fetched only once (during the REPEAT instruction, as would be expected). The last iteration of the repeated instruction fetches the next instruction.</p> <p>The repeat count is decremented during each iteration. When it equals zero (during the penultimate loop), PC increment and instruction fetch is re-enabled (RA=0) allowing the final iteration to fetch the next instruction and normal execution continues.</p> <p>The repeated instruction can be interrupted before any iteration by any interrupt. Note that the user must save and restore RCOUNT to support nested repeats (e.g., from within the interrupt service routine).</p> <p>The 'k' bits are an unsigned literal that specifies the loop count.</p> <p>Note: If lit5 = 0, RA is not set and the subsequent instruction executes as normal (equivalent to a loop count of one)</p>		
I-Words:	0.5		
Cycles:	1		

REPEAT	Repeat next instruction, variable count								
Syntax:	{label:}	REPEAT	Wn						
Operands:	Wn ∈ [W0 ... W15]								
Operation:	(Wn[31:0]) → RCOUNT[31:0] (Loop Count Register) (PC) + 2 → PC 1 → RA (Enable Code Looping)								
Status Affected:	RA (if (Wn) > 0)								
Encoding:	1101	100U	UUUU	ssss	UUUU	UUUU	UUUU	UUUU	U010
Description:	<p>The instruction immediately following the REPEAT instruction is executed (Wn)+1 times. The repeated instruction is held in the instruction register for all iterations and so is fetched only once (during the REPEAT instruction, as would be expected). The last iteration of the repeated instruction fetches the next instruction.</p> <p>The repeat count is decremented during each iteration. When it equals zero (during the penultimate loop), PC increment and instruction fetch is re-enabled (RA=0) allowing the final iteration to fetch the next instruction and normal execution continues.</p> <p>The repeated instruction can be interrupted before any iteration by any interrupt. Note that the user must save and restore RCOUNT to support nested repeats (e.g., from within the interrupt service routine).</p> <p>The 's' bits specify the Wn register that contains the loop count</p> <p>Note: If Wn = 0, RA is not set and the subsequent instruction executes as normal (equivalent to a loop count of one).</p>								
I-Words:	1								
Cycles:	1								

RESET		Reset							
Syntax:	{label:}	RESET							
Operands:	None								
Operation:	Force all registers and flag bits that are affected by an MCLR reset to their Reset condition.								
Status Affected:	None								
Encoding:	1111	101U	UUUU	UUUU	UUUU	UUUU	UUUU	UUUU	0011
Description:	This instruction provides a means to execute a software reset.								
I-Words:	1								
Cycles:	1								

Example 1: 00202A RESET ; Execute software RESET on dsPIC33A

Before Instruction			After Instruction		
PC	00 202A		PC	00 0000	
W0	8901		W0	0000	
W1	08BB		W1	0000	
W2	B87A		W2	0000	
W3	872F		W3	0000	
W4	C98A		W4	0000	
W5	AAD4		W5	0000	
W6	981E		W6	0000	
W7	1809		W7	0000	
W8	C341		W8	0000	
W9	90F4		W9	0000	
W10	F409		W10	0000	
W11	1700		W11	0000	
W12	1008		W12	0000	
W13	6556		W13	0000	
W14	231D		W14	0000	
W15	1704		W15	0800	
SPLIM	1800		SPLIM	0000	
TBLPAG	007F		TBLPAG	0000	
PSVPAG	0001		PSVPAG	0000	
CORCON	00F0		CORCON	0020	(SATDW = 1)
RCON	0000		RCON	0040	(SWR = 1)
SR	0021	(IPL, C = 1)	SR	0000	

RETFIE Return from Interrupt

Syntax: {label;} RETFIE

Operands: None

Operation: (W15) - 4 → W15
 TOS[23:1] → (PC[23:1]),
 (W15) - 4 → W15
 TOS[15:0] → (SR[31:0]),
 1'b0 → PC[0]
 NOP → Instruction Register

Status Affected: OA, OB, SA, SB, (OAB), (SAB), IPL[3:0], RA, N, OV, Z, C

Encoding: 0111 001U UUUU 0000

Description: Return from interrupt service routine to either a 32-bit or 16-bit instruction. The stack is popped and the Top of Stack (TOS) is loaded into PC[23:1] (PC[0] is always clear). The stack is popped again and the Top of Stack (TOS) is loaded into the SR.
 In addition, this instruction will also manage hardware context switching (IPL-based).

Note:

- OAB and SAB will reflect the returned state of OA/OB and SA/SB respectively.

I-Words: 0.5

Cycles: 4

Note:

- Return PC instruction fetch is not executed if an exception is pending, making effective instruction execution time (for latency) one cycle.

Example 1: 000A26 RETFIE ; Return from ISR

Before Instruction		After Instruction	
PC	00 0A26	PC	01 0230
W15	0834	W15	0830
Data 0830	0230	Data 0830	0230
Data 0832	8101	Data 0832	8101
CORCON	0001	CORCON	0001
SR	0000	SR	0081 (IPL = 4, C = 1)

Example 2: 008050 RETFIE ; Return from ISR

Before Instruction		After Instruction	
PC	00 8050	PC	00 7008
W15	0926	W15	0922
Data 0922	7008	Data 0922	7008
Data 0924	0300	Data 0924	0300
CORCON	0000	CORCON	0000
SR	0000	SR	0003 (Z, C = 1)

RETLW	Return with Literal in Wd								
Syntax:	{label:}	RETLW.b	lit16,	Wnd					
		RETLW.bz							
		RETLW{.w}							
		RETLW.l							
Operands:	Wnd ∈ [W0 ... W14]; lit16 ∈ [0 ... 65535]								
Operation:	(W15) - 4 → W15 TOS[23:1] → (PC[23:1]), 1'b0 → PC[0] Byte mode: lit16[7:0] → Wnd[7:0] Extended Byte mode: 24'b0, lit16[7:0] → Wnd Word or Long Word mode: 16'b0, lit16 → Wnd NOP → Instruction Register								
Status Affected:	None								
Encoding:	1100	110L	dddd	kkkk	kkkk	kkkk	kkkk	kkkk	BU10
Description:	Return with a literal value in Wnd. When operating in Long Word, Word or Extended Byte mode, the literal is zero-extended to 32-bits before being written into Wnd. When operating in Byte mode, the literal is loaded into the LSb of Wnd, leaving the MSb of Wnd unchanged. The 'L' and 'B' bits select operation data width. The 'd' bits select the destination register. The 'k' bits define the literal. Notes: 1. W15 is excluded from being a valid destination for the return literal value. 2. Word and Long Word operating modes are equivalent. 3. Return PC instruction fetch is not executed if an exception is pending, making effective instruction execution time (for latency) one cycle.								
I-Words:	1								
Cycles:	3 (refer to note 3)								

RETURN		Return	
Syntax:	{label:}	RETURN	
Operands:	None		
Operation:	(W15) - 4 → W15 TOS[23:1] → (PC[23:1]) 1'b0 → PC[0] NOP → Instruction Register		
Status Affected:	None		
Encoding:	0111	001U	UUUU 0001
Description:	Return from subroutine to either a 32-bit or 16-bit instruction. The stack is popped and the Top-of-Stack (TOS) is loaded into PC[23:0]. PC[0] is always clear.		
I-Words:	0.5		
Cycles:	3		
	Note:		
	1. Return PC instruction fetch is not executed if an exception is pending, making effective instruction execution time (for latency) 1 cycle.		

Example 1: 001A06 RETURN ; Return from subroutine					
Before Instruction			After Instruction		
PC	00 1A06		PC	01 0004	
W15	1248		W15	1244	
Data 1244	0004		Data 1244	0004	
Data 1246	0001		Data 1246	0001	
SR	0000		SR	0000	

Example 2: 005404 RETURN ; Return from subroutine					
Before Instruction			After Instruction		
PC	00 5404		PC	00 0966	
W15	090A		W15	0906	
Data 0906	0966		Data 0906	0966	
Data 0908	0000		Data 0908	0000	
SR	0000		SR	0000	

RLC		Rotate Left Ws through Carry	
Syntax:	{label:}	RLC.b	Ws, Wd
		RLC.bz	[Ws], [Wd]
		RLC{.w}	[Ws++], [Wd++]
		RLC.l	[Ws--], [Wd--]
			[++Ws], [++Wd]
			[--Ws], [--Wd]
Operands:	Ws ∈ [W0 ... W15]; Wd ∈ [W0 ... W15]		
Operation:	<u>For Byte operation:</u> (C) → Wd[0], (Ws[6:0]) → Wd[7:1], (Ws<7>) → C <u>For Word operation:</u> (C) → Wd[0], (Ws[14:0]) → Wd[15:1], (Ws[15]) → C <u>For Long Word operation:</u> (C) → Wd[0], (Ws[30:0]) → Wd[31:1], (Ws[31]) → C		
Status Affected:	C, N, Z		
Encoding:	s011	000L	dddd ssss pppq qqUU UUUU BU00
Description:	Rotate the contents of the source register Ws one bit to the left through the carry flag and place the result in the destination register Wd. In all cases, N and Z are set based on an evaluation of the result using the data size of the operation. The 'S' bit selects instruction size. The 'L' and 'B' bits select operation data width. The 's' bits select the source register. The 'd' bits select the destination register. The 'p' bits select the source addressing mode. The 'q' bits select the destination addressing mode.		
I-Words:	1 or 0.5		
Cycles:	1		

Example 1 **RLC.B W0, W3** **;Rotate Left w/C (W0) (Byte mode)**
;Store the result in W3

Before Instruction		After Instruction	
W0	9976	W0	9976
W3	5879	W3	58ED
SR	0001 (C = 1)	SR	0009 (N = 1)

Example 2 **[W2++],[W8]** **;Rotate Left w/C [W2] (Word mode)**
;Post-increment W2
;Store result in [W8]

Before Instruction		After Instruction	
W2	2008	W2	200A
W8	094E	W8	094E
Data 094E	3689	Data 094E	8082 (N = 1)
Data 2008	C041	Data 2008	C041
SR	0001 (C = 1)	SR	0009 (N, C = 1)

RLC		Rotate Left f through Carry			
Syntax:	{label:}	RLC.b	f	{Wnd}	{WREG}
		RLC.bz			
		RLC{.w}			
		RLC.l			
Operands:	f ∈ [0 ... 64KB]; Wnd ∈ [W0 ... W14]				
Operation:	<u>For Byte operation:</u> (C) → Dest[0], (f[6:0]) → Dest[7:1], (f<7>) → C <u>For Word operation:</u> (C) → Dest[0], (f[14:0]) → Dest[15:1], (f[15]) → C <u>For Long Word operation:</u> (C) → Dest[0], (f[30:0]) → Dest[31:1], (f[31]) → C				
Status Affected:	C, N, Z				
Encoding:	1011	000L	dddd	ffff	ffff ffff ffff BD01
Description:	Rotate the contents of the file register f one bit to the left through the carry flag and place the result in the destination designated by D. If the optional Wnd is specified, D=0 and store result in Wnd; otherwise, D=1 and store result in the file register. The 'L' and 'B' bits select operation data width. The 'D' bit selects the destination. The 'f' bits select the address of the file register. The 'd' bits select the Working register.				
I-Words:	1				
Cycles:	1				

Example 1	RLC.B 0x1233	; Rotate Left w/ C (0x1233) (Byte mode)
-----------	--------------	--

Before Instruction		After Instruction	
Data 1232	E807	Data 1232	D007
SR	0000	SR	0009 (N, C = 1)

Example 2	RLC 0x820, WREG	; Rotate Left w/ C (0x820) (Word mode) ; Store result in WREG
-----------	-----------------	---

Before Instruction		After Instruction	
WREG (W0)	5601	WREG (W0)	42DD
Data 0820	216E	Data 0820	216E
SR	0001 (C = 1)	SR	0000 (C = 0)

RLNC		Rotate Left Ws (No Carry)		
Syntax:	{label:}	RLNC.b	Ws,	Wd
		RLNC.bz	[Ws],	[Wd]
		RLNC{.w}	[Ws++],	[Wd++]
		RLNC.l	[Ws--],	[Wd--]
			[++Ws],	[++Wd]
			[--Ws],	[--Wd]
Operands:	Ws ∈ [W0 ... W15]; Wd ∈ [W0 ... W15]			
Operation:	<p><u>For Byte operation:</u> (Ws[6:0]) → Wd[7:1], (Ws<7>) → Wd[0]</p> <p><u>For Word operation:</u> (Ws[14:0]) → Wd[15:1], (Ws[15]) → Wd[0]</p> <p><u>For Long Word operation:</u> (Ws[30:0]) → Wd[31:1], (Ws[31]) → Wd[0]</p>			
Status Affected:	N, Z			
Encoding:	s011	001L	dddd	ssss pppq qqUU UUUU BU00
Description:	<p>Rotate the contents of the source register Ws one bit to the left and place the result in the destination register Wd. The Carry Flag bit is not affected.</p> <p>The 'S' bit selects instruction size.</p> <p>The 'L' and 'B' bits select operation data width.</p> <p>The 's' bits select the source register.</p> <p>The 'd' bits select the destination register.</p> <p>The 'p' bits select the source addressing mode.</p> <p>The 'q' bits select the destination addressing mode.</p>			
I-Words:	1 or 0.5			
Cycles:	1			

Example 1 **RLNC.B W0, W3** **; Rotate Left (W0) (Byte mode)**
; Store the result in W3

Before Instruction		After Instruction	
W0	9976	W0	9976
W3	5879	W3	58EC
SR	0001	SR	0009 (N, C = 1)

Example 2 **RLNC [W2++], [W8]** **; Rotate Left [W2] (Word mode)**
; Post-increment W2
; Store result in [W8]

Before Instruction		After Instruction	
W2	2008	W2	200A
W8	094E	W8	094E
Data 094E	3689	Data 094E	8083
Data 2008	C041	Data 2008	C041
SR	0001 (C = 1)	SR	0009 (N, C = 1)

RLNC		Rotate Left f (No Carry)			
Syntax:	{label:}	RLNC.b	f	{Wnd}	{WREG}
		RLNC.bz			
		RLNC{.w}			
		RLNC.l			
Operands:	f ∈ [0 ... 64KB]; Wnd ∈ [W0 ... W14]				
Operation:	<u>For Byte operation:</u> (f[6:0]) → Dest[7:1], (f<7>) → Dest[0]				
	<u>For Word operation:</u> (f[14:0]) → Dest[15:1], (f[15]) → Dest[0]				
	<u>For Long Word operation:</u> (f[30:0]) → Dest[31:1], (f[31]) → Dest[0]				
Status Affected:	N, Z				
Encoding:	1011	001L	dddd	ffff	ffff ffff ffff BD01
Description:	Rotate the contents of the file register f one bit to the left and place the result in the destination designated by D. If the optional Wnd is specified, D=0 and store result in Wnd; otherwise, D=1 and store result in the file register. The Carry Flag bit is not affected. The 'L' and 'B' bits select operation data width. The 'D' bit selects the destination. The 'f' bits select the address of the file register. The 'd' bits select the Working register.				
I-Words:	1				
Cycles:	1				

Example 1	RLNC.B 0x1233				; Rotate Left (0x1233) (Byte mode)
	Before Instruction			After Instruction	
	Data 1232	E807		Data 1233	D107
	SR	0000		SR	0008 (N = 1)
Example 2	RLNC 0x820, WREG				; Rotate Left (0x820) (Word mode)
					; Store result in WREG
	Before Instruction			After Instruction	
	WREG (W0)	5601		WREG (W0)	42DC
	Data 0820	216E		Data 0820	216E
	SR	0001 (C = 1)		SR	0000 (C = 0)

RRC		Rotate Right Ws through Carry	
Syntax:	{label:}	RRC.b	Ws, Wd
		RRC.bz	[Ws], [Wd]
		RRC{.w}	[Ws++], [Wd++]
		RRC.l	[Ws--], [Wd--]
			[++Ws], [++Wd]
			[--Ws], [--Wd]
Operands:		Ws ∈ [W0 ... W15]; Wd ∈ [W0 ... W15]	
Operation:		<u>For Byte operation:</u> (C) → Wd<7>, (Ws[7:1]) → Wd[6:0], (Ws[0]) → C <u>For Word operation:</u> (C) → Wd[15], (Ws[15:1]) → Wd[14:0], (Ws[0]) → C <u>For Long Word operation:</u> (C) → Wd[31], (Ws[31:1]) → Wd[30:0], (Ws[0]) → C	
Status Affected:		C, N, Z	
Encoding:		s011	010L dddd ssss pppq qqUU UUUU BU00
Description:		Rotate the contents of the source register Ws one bit to the right through the carry flag and place the result in the destination register Wd. The 'S' bit selects instruction size. The 'L' and 'B' bits select operation data width. The 's' bits select the source register. The 'd' bits select the destination register. The 'p' bits select the source addressing mode. The 'q' bits select the destination addressing mode.	
I-Words:		1 or 0.5	
Cycles:		1	

```

Example 1:      RRC.B W0, W3                                ; Rotate Right w/ C (W0)
                                                           ; (Byte mode)
                                                           ; Store the result in W3
    
```

Before Instruction		After Instruction	
W0	9976	W0	9976
W3	5879	W3	58BB
SR	0001	SR	0008 (N = 1)
	(C = 1)		

```

Example 2:      RRC [W2++], [W8]                          ; Rotate Right w/ C
                                                           ; [W2] (Word mode)
                                                           ; Post-increment
                                                           ; W2
                                                           ; Store result in
                                                           ; [W8]
    
```

Before Instruction		After Instruction	
W2	2008	W2	200A
W8	094E	W8	094E
Data 094E	3689	Data 094E	E020
Data 2008	C041	Data 2008	C041
SR	0001	SR	0009 (N, C = 1)
	(C = 1)		

RRC		Rotate Right f through Carry			
Syntax:	{label:}	RRC.b	f	{Wnd}	{WREG}
		RRC.bz			
		RRC{.w}			
		RRC.l			
Operands:	f ∈ [0 ... 64KB]; Wnd ∈ [W0 ... W14]				
Operation:	<u>For Byte operation:</u> (C) → Dest[7], (f[7:1]) → Dest[6:0], (f[0]) → C <u>For Word operation:</u> (C) → Dest[15], (f[15:1]) → Dest[14:0], (f[0]) → C <u>For Long Word operation:</u> (C) → Dest[31], (f[31:1]) → Dest[30:0], (f[0]) → C				
Status Affected:	C, N, Z				
Encoding:	1011	010L	dddd	ffff	ffff ffff ffff BD01
Description:	Rotate the contents of the file register f one bit to the left through the carry flag and place the result in the destination designated by D. If the optional Wnd is specified, D=0 and store result in Wnd; otherwise, D=1 and store result in the file register. The 'L' and 'B' bits select operation data width. The 'D' bit selects the destination. The 'f' bits select the address of the file register. The 'd' bits select the Working register.				
I-Words:	1				
Cycles:	1				

Example 1	RRC.B 0x1233	;Rotate Right w/C (0x1233) (Byte mode)
-----------	--------------	---

Before Instruction		After Instruction	
Data	1232 E807	Data	1232 7407
SR	0000	SR	0000

Example 2:	RRC 0x820, WREG	; Rotate Right w/C (0x820) (Word mode) ; Store result in WREG
------------	-----------------	--

Before Instruction		After Instruction	
WREG (W0)	5601	WREG (W0)	90B7
Data	0820 216E	Data	0820 216E
SR	0001 (C = 1)	SR	0008 (N = 1)

RRNC		Rotate Right Ws (No Carry)		
Syntax:	{label:}	RRNC.b	Ws,	Wd
		RRNC.bz	[Ws],	[Wd]
		RRNC{.w}	[Ws++],	[Wd++]
		RRNC.l	[Ws--],	[Wd--]
			[++Ws],	[++Wd]
			[--Ws],	[--Wd]
Operands:	Ws ∈ [W0 ... W15]; Wd ∈ [W0 ... W15]			
Operation:	<u>For Byte operation:</u> (Ws[7:1]) → Wd[6:0], (Ws[0]) → Wd<7> <u>For Word operation:</u> (Ws[15:1]) → Wd[14:0], (Ws[0]) → Wd[15] <u>For Long Word operation:</u> (Ws[31:1]) → Wd[30:0], (Ws[0]) → Wd[31]			
Status Affected:	N, Z			
Encoding:	s011	011L	dddd	ssss pppq qqUU UUUU BU00
Description:	Rotate the contents of the source register Ws one bit to the right and place the result in the destination register Wd. The Carry Flag bit is not affected. The 'S' bit selects instruction size. The 'L' and 'B' bits select operation data width. The 's' bits select the source register. The 'd' bits select the destination register. The 'p' bits select the source addressing mode. The 'q' bits select the destination addressing mode.			
I-Words:	1 or 0.5			
Cycles:	1			

Example 1 **RRNC.B W0, W3** **; Rotate Right (W0) (Byte mode)**
; Store the result in W3

Before Instruction		After Instruction	
W0	9976	W0	9976
W3	5879	W3	583B
SR	0001 (C = 1)	SR	0001 (C = 1)

Example 2: **RRNC [W2++], [W8]** **; Rotate Right [W2] (Word mode)**
; Post-increment W2
; Store result in [W8]

Before Instruction		After Instruction	
W2	2008	W2	200A
W8	094E	W8	094E
Data	094E 3689	Data	094E E020
Data	2008 C041	Data	2008 C041
SR	0000 (C = 1)	SR	0008 (N = 1)

RRNC		Rotate Right f (No Carry)			
Syntax:	{label:}	RRNC.b	f	{Wnd}	{WREG}
		RRNC.bz			
		RRNC{.w}			
		RRNC.l			
Operands:	f ∈ [0 ... 64KB]; Wnd ∈ [W0 ... W14]				
Operation:	<u>For Byte operation:</u> (f[7:1]) → Dest[6:0], (f[0]) → Dest[7] <u>For Word operation:</u> (f[15:1]) → Dest[14:0], (f[0]) → Dest[15] <u>For Long Word operation:</u> (f[31:1]) → Dest[30:0], (f[0]) → Dest[31]				
Status Affected:	N, Z				
Encoding:	1011	011L	dddd	ffff	ffff ffff ffff BD01
Description:	Rotate the contents of the file register f one bit to the right, and place the result in the destination designated by D. If the optional Wnd is specified, D=0 and store result in Wnd; otherwise, D=1 and store result in the file register. The Carry Flag bit is not affected. The 'L' and 'B' bits select operation data width. The 'D' bit selects the destination. The 'f' bits select the address of the file register. The 's' bits select the Working register.				
I-Words:	1				
Cycles:	1				

Example 1 **RRNC.B 0x1233** **; Rotate Right (0x1233) (Byte mode)**

Before Instruction		After Instruction	
Data 1232	E807	Data 1232	7407
SR	0000	SR	0000

Example 2: **RRNC 0x820, WREG** **; Rotate Right (0x820) (Word mode)**
; Store result in WREG

Before Instruction		After Instruction	
WREG (W0)	5601	WREG (W0)	10B7
Data 0820	216E	Data 0820	216E
SR	0001 (C = 1)	SR	0001 (C = 1)

SAC		Store Accumulator			
Syntax:	{label:}	SAC{.w}	A,	{ Slit6, }	Wd
		SAC.l	B,		[Wd]
					[Wd++]
					[Wd--]
					[--Wd]
					[++Wd]
					[Wd+Wb]
Operands:	Slit6 ∈ [-32 ... +31]; Wd ∈ [W0 ... W15] (see note 4); Wb ∈ [W0 ... W15]				
Operation:	<u>For Long Word operation:</u> Shift _{Slit6} (ACC) (ACC[63:32]) → Wd[31:0]				
	<u>For Word operation:</u> Shift _{Slit6} (ACC) (ACC[63:48]) → Wd[15:0] (see note 3)				
Status Affected:	None				
Encoding:	1100	01AL	www	ddd	UUUq qqkk kkkk 0011
Description:	Read then optionally shift accumulator value, then store the truncated result to the destination Effective Address. Any shift will apply only to data read from the accumulator, so will not modify the accumulator contents. The shift value is sourced from a signed literal value. After the shift, a word operation (SAC{.w}) assumes that the value is a Q1.15 signed fraction. Accordingly, the post-shift result [63:48] is then written to the Effective Address. After the shift, a long word operation (SAC.l) assumes that the value is a Q1.31 signed fraction. Accordingly, the post-shift result [63:32] is then written to the Effective Address. The 'L' bit selects word or long word operation. The 'A' bit specifies the source accumulator. The 'd' bits specify the destination register Wd. The 'q' bits select the destination addressing mode. The 'w' bits specify the offset register Wb. The 'k' bits encode the optional operand Slit6 which determines the amount of the accumulator shift. If operand Slit6 is absent, set literal to all 0's.				
	Notes:				
	1. Positive values of operand Slit6 represent arithmetic shift right. Negative values of operand Slit6 represent shift left. 2. When the destination is register direct (W-reg), the result is either zero extended (CORCON.US = 1) or sign extended (CORCON.US = 0) to 32-bits. 3. Register direct destination W15 not permitted.				
I-Words:	1				
Cycles:	1				

Example 1: SAC A, #4, W5 ; Right shift ACCA by 4
 ; Store result to W5
 ; CORCON = 0x0010 (SATDW = 1)

	Before Instruction		After Instruction	
W5	B900	W5	0120	
ACCA	00 120F FF00	ACCA	00 120F FF00	
CORCON	0010	CORCON	0010	
SR	0000	SR	0000	

```

Example 2:      SAC B, #-4, [W5++]          ; Left shift ACCB by 4
                                                         ; Store result to [W5], Post-increment W5
                                                         ; CORCON = 0x0010 (SATDW = 1)

```

	Before Instruction		After Instruction	
W5	2000	W5	2002	
ACCB	FF C891 8F4C	ACCB	FF C891 1F4C	
Data 2000	5BBE	Data 2000	8000	
CORCON	0010	CORCON	0010	
SR	0000	SR	0000	

SE	Sign Extend Ws								
Syntax:	{label:}	SE.b	Ws,	Wnd					
		SE.w	[Ws],						
			[Ws++],						
			[Ws--],						
			[++Ws],						
			[--Ws],						
			[Ws+Wb],						
Operands:	Ws ∈ [W0 ... W15]; Wb ∈ [W0 ... W15]; Wnd ∈ [W0 ... W14]								
Operation:	<u>If Byte Mode:</u> {24{Ws[7]}}, Ws[7:0] → Wnd[31:0] <u>If Word Mode:</u> {16{Ws[15]}}, Ws[15:0] → Wnd[31:0]								
Status Affected:	C,N,Z								
Encoding:	S111	110B	dddd	ssss	pppU	UUww	wwUU	UU00	
Description:	Sign-extend an 8-bit or 16-bit signed value in Ws to a 32-bit signed value, then write the result back to Wnd. C is set to the complement of N. The 'S' bit selects instruction size. The 'B' bit selects byte or word operation. The 's' bits select the source register. The 'd' bits select the destination register. The 'p' bits select the source addressing mode. The 'w' bits define the offset Wb. Notes: 1. This operation always writes a long word. 2. Unlike all other Word mode instructions, word data does not always zero extend.								
I-Words:	1 or 0.5								
Cycles:	1								

Example:1 SE.b W0, W3 ;Sign extend a byte in W0, store it in W3

Before execution		After execution	
W0	0x00000089	W0	0x00000089
W3	0x00000000	W3	0xFFFFF89
SR[7:0]	8'b00000000	SR[7:0]	8'b00000000

Example:2 SE W0, W3 ;Sign extend a word in W0, store it in W3

Before execution		After execution	
W0	0x12347879	W0	0x12347879
W3	0x00000000	W3	0x00007879
SR[7:0]	8'b00000000	SR[7:0]	8'b00001000 (N = 1)

SETM	Set f
Syntax:	{label;} SETM.b f SETM{.w} SETM.l
Operands:	f ∈ [0 ... 1MB]
Operation:	0xFFFFFFFF → file register for long operation 0xFFFF → file register for word operation 0xFF → file register for byte operation
Status Affected:	None
Encoding:	1010 111L ffff ffff ffff ffff ffff B101
Description:	Set the file register. The 'L' and 'B' bits select operation data width. The 'f' bits select the address of the file register. Note: 1. Accessible file address space is 1MB.
I-Words:	1
Cycles:	1

SFTAC	Arithmetic Shift Accumulator								
Syntax:	{label:}	SFTAC{.w} A,		Ws					
		SFTAC.l	B,	[Ws]					
				[Ws++]					
				[Ws--]					
				[++Ws]					
				[--Ws]					
				[Ws+Wb]					
Operands:		Ws ∈ [W0 ... W15]; Wb ∈ [W0 ... W15]							
Operation:		Shift _(Ws) (ACC)							
Status Affected:		OA, SA or OB, SB							
Encoding:		1100	11AL	www	sss	pppU	UUUU	UUUU	0011
Description:		<p>Arithmetic shift of accumulator.</p> <p>The shift value is sourced from the word or long word signed contents of Ws[5:0]. If Ws is positive or zero, the shift will be a right shift of between 1 and 31 bits maximum (or no shift if Ws is 0). If Ws is negative, the shift will be a left shift of between 1 and 32 bits maximum.</p> <p>If Ws is out of range (i.e., when Ws[15:5] for word, or Ws[31:5] for long word are not equal to all 1's or all 0's), a math error trap will be requested during execution. The instruction will continue to execute but the result will not be written to the destination accumulator, and the SR will not be modified.</p> <p>The 'L' bit selects word or long word Ws (shift count).</p> <p>The 'A' bit selects the accumulator for the result.</p> <p>The 's' bits select the Ws register.</p> <p>The 'p' bits select the source addressing mode.</p> <p>The 'w' bits define the offset Wb.</p>							
I-Words:		1							
Cycles:		1							

SFTAC		Arithmetic Shift Accumulator							
Syntax:	{label:}	SFTAC	A,	Slit6					
			B,						
Operands:	Slit6 \in [-32 ... 31]								
Operation:	Shift _k (ACC)								
Status Affected:	OA, SA or OB, SB								
Encoding:	1100	11AU	UUUU	UUUU	UUUU	UUkk	kkkk	0111	
Description:	<p>Arithmetic shift of accumulator.</p> <p>The Slit6 is used as the shift amount. If Slit6 is positive or zero, the shift will be a right shift of between 0 and 31 bits maximum. If Slit6 is negative, the shift will be a left shift of between 1 and 32 bits maximum.</p> <p>The 'A' bit selects the accumulator for the result.</p> <p>The 'k' bits determine the number of bits to be shifted.</p>								
I-Words:	1								
Cycles:	1								

SL	Shift Left by 1			
Syntax:	{label:}	SL.b	Ws,	Wd
		SL.bz	[Ws],	[Wd]
		SL{.w}	[Ws++],	[Wd++]
		SL.l	[Ws--],	[Wd--]
			[++Ws],	[++Wd]
			[--Ws],	[--Wd]
Operands:	Ws ∈ [W0 ... W15]; Wd ∈ [W0 ... W15]			
Operation:	For long word operation: (Ws[31]) → C, (Ws[30:0]) → Wd[31:1], 0 → Wd[0]			
	For word operation: (Ws[15]) → C, (Ws[14:0]) → Wd[15:1], 0 → Wd[0]			
	For byte operation: (Ws[7]) → C, (Ws[6:0]) → Wd[7:1], 0 → Wd[0]			
Status Affected:	C,N,Z			
Encoding:	s010	110L	dddd	ssss
			pppq	qqUU
				UUUU
				B000
Description:	Shift left the contents of the source register Ws by 1 bit, placing the result in the destination register Wd. Destination register direct Extended Byte or Word mode will zero-extend the result to 32-bits, then write to Wd. The 'S' bit selects instruction size. The 'L' and 'B' bits select operation data width. The 's' bits select the source register. The 'd' bits select the destination register. The 'p' bits select the source addressing mode. The 'q' bits select the destination addressing mode.			
I-Words:	1 or 0.5			
Cycles:	1			

SL		Shift Left f			
Syntax:	{label:}	SL.b	f	{,Wnd}	{,WREG}
		SL.bz			
		SL{.w}			
		SL.l			
Operands:	f ∈ [0 ... 64KB]; Wnd ∈ [W0 ... W14]				
Operation:	For byte operation: (f<7>) → (C), (f[6:0]) → Dest[7:1], 0 → Dest[0] For word operation: (f[15]) → (C), (f[14:0]) → Dest[15:1], 0 → Dest[0] For long word operation: (f[31]) → (C), (f[30:0]) → Dest[31:1], 0 → Dest[0]				
Status Affected:	C, N, Z				
Encoding:	1010	010L	dddd	ffff	ffff ffff ffff BD01
Description:	Shift the contents of the file register f one bit to the left with a '0' fill. The carry flag is set if the MSB of f is '1'. Place the result in the destination designated by D. If the optional Wnd is specified, D = 0 and store result in Wnd; otherwise, D = 1 and store result in the file register. The 'L' and 'B' bits select operation data width. The 'D' bit selects the destination. The 'f' bits select the address of the file register. The 'd' bits select the Working register.				
I-Words:	1				
Cycles:	1				

Example 1:	SL.B 0x909	; Shift left (0x909) (Byte mode)			
		Before Instruction		After Instruction	
		Data 0908	9439	Data 0908	0839
		SR	0000	SR	0001 (C = 1)

Example 2:	SL 0x1650, WREG	; Shift left (0x1650) (Word mode) ; Store result in WREG			
		Before Instruction		After Instruction	
		WREG (W0)	0900	WREG (W0)	80CA
		Data 1650	4065	Data 1650	4065
		SR	0000	SR	0008 (N = 1)

SL	Shift Left by Wb				
Syntax:	{label:}	SL.b	Ws,	Wb,	Wd
		SL.bz	[Ws],		[Wd]
		SL{.w}	[Ws++],		[Wd++]
		SL.l	[Ws--],		[Wd--]
			[++Ws],		[++Wd]
			[--Ws],		[--Wd]
Operands:	Ws ∈ [W0 ... W15]; Wb ∈ [W0 ... W15]; Wd ∈ [W0 ... W15]				
Operation:	<p>Wb[15:0] → Shift_Val</p> <p><u>For long word operation:</u></p> <p>32'b0, Ws[31:0] → Shift_In[63:0]</p> <p>Shift left Shift_In[63:0] by Shift_Val → Shift_Out[63:0]</p> <p>Shift_Out[31:0] → Wd</p> <p><u>For word operation:</u></p> <p>48'b0, Ws[15:0] → Shift_In[63:0]</p> <p>Shift left Shift_In[63:0] by Shift_Val → Shift_Out[63:0]</p> <p>Shift_Out[15:0] → Wd</p> <p><u>For byte operation:</u></p> <p>56'b0, Ws[7:0] → Shift_In[63:0]</p> <p>Shift left Shift_In[63:0] by Shift_Val → Shift_Out[63:0]</p> <p>Shift_Out[7:0] → Wd</p>				
Status Affected:	N,Z				
Encoding:	1010	110L	www	ddd	pppq qqss ssUU B100
Description:	<p>Shift left the contents of the source register Ws by Wb bits, placing the result in the destination register Wd.</p> <p>When used in isolation, this instruction will generate the correct result for any shift value in Wb[15:0]:</p> <ul style="list-style-type: none"> • For a byte operation shift value > 7, Wd[7:0]=0x00 • For a word operation shift value > 15, Wd[15:0]=0x0000 • For a long word operation shift value > 31, Wd=0x00000000 <p>When used in conjunction with the SLMW instruction for multi-precision multi-bit shift operations, this instruction will not generate a correct result for any shift value greater than 32.</p> <p>Any data held in Wb[31:16] will have no effect.</p> <p>Destination register direct Extended Byte or Word mode will zero-extend the result to 32-bits, then write to Wd.</p> <p>The 'L' and 'B' bits select operation data width.</p> <p>The 's' bits select the source register.</p> <p>The 'w' bits select the base (shift count) register.</p> <p>The 'd' bits select the destination register.</p> <p>The 'p' bits select the source addressing mode.</p> <p>The 'q' bits select the destination addressing mode.</p>				
I-Words:	1				
Cycles:	1				

SLAC		Store Lower Accumulator					
Syntax:	{label:}	SLAC{.l}	A,	{ Slit6 , }	Wd		
			B,		[Wd]		
					[Wd++]		
					[Wd--]		
					[--Wd]		
					[++Wd]		
					[Wd+Wb]		
Operands:	Slit6 ∈ [-32 ... +31]; Wd ∈ [W0 ... W15] (see note 2); Wb ∈ [W0 ... W15]						
Operation:	Shift _{Slit6} (ACC) (ACC[31:0]) → Wd[31:0]						
Status Affected:	None						
Encoding:	1100	01A1	www	ddd	UUUq	qqkk	kkkk 0111
Description:	<p>Read then optionally shift accumulator value, then store post-shift ACC[31:0] to the destination Effective Address. Any shift will apply only to data read from the accumulator so will not modify the accumulator contents. The shift value is sourced from a signed literal value. The 'A' bit specifies the source accumulator.</p> <p>The 'd' bits specify the destination register Wd.</p> <p>The 'q' bits select the destination addressing mode.</p> <p>The 'w' bits specify the offset register Wb.</p> <p>The 'k' bits encode the optional operand Slit6 which determines the amount of the accumulator shift. If operand Slit6 is absent, set literal to all 0's.</p> <p>Notes:</p> <ol style="list-style-type: none"> Positive values of operand Slit6 represent arithmetic shift right. Negative values of operand Slit6 represent shift left. Register direct destination W15 not permitted. 						
I-Words:	1						
Cycles:	1						
Example:1	SLAC A, #4, w8			;Right shift value of ACCAL by 4; store the results in w8 ; with CORCON.US = 0			
	Before execution			After execution			
	ACCA	0xFF_9022_2EE1 _5633_9078		ACCA	0xFF_9022_2EE1 _5633_9078		
	w8	0x00000000		w8	0x05633907		

SLM	Shift Left Multi-Precision by Short Literal						
Syntax:	{label:}	SLM{.l}	Ws,	lit5,	Wnd		
			[Ws],				
			[Ws++],				
			[Ws--],				
			[++Ws],				
			[--Ws],				
Operands:	Ws ∈ [W0 ... W15]; lit5 ∈ [0...31]; Wnd ∈ [W0 ... W13]						
Operation:	lit5[4:0] → Shift_Val 0 → Left shift input 32'b0,Ws[31:0] → Shift_In[63:0] Shift left Shift_In[63:0] by Shift_Val → Shift_Out[63:0] Shift_Out[31:0] → Wnd Shift_Out[63:32] Wnd+1 → Wnd+1						
Status Affected:	Z						
Encoding:	1110	000k	kkkk	dddd	pppU	UUss	ssUU 1011
Description:	<p>Shift left the contents of the source register Ws by lit5 bits (up to 31 positions), placing the result in the destination register Wnd. The register containing the next most significant data word will already contain an intermediate shift result. Bitwise OR this value with the data shifted out of Ws in order to create the final shift result, then update the corresponding destination register.</p> <p>This instruction is intended to be used in conjunction with the SLK instruction to support multi-precision multi-bit shift operations.</p> <p>The Z bit is "sticky" (can only be cleared).</p> <p>The 's' bits select the source register.</p> <p>The 'd' bits select the destination register.</p> <p>The 'p' bits select the source addressing mode.</p> <p>The 'k' bits provide the literal operand.</p> <p>Note: This instruction operates in Long Word mode only.</p>						
I-Words:	1						
Cycles:	2						

Example:1	SLAC	A, #4, w8	;Right shift value of ACCAL by 4; store the re
	Before execution		
	ACCA	0xFF_9022_2EE1_5633	
		_9078	
	w8	0x00000000	

SLM	Shift Left Multi-Precision by Wb								
Syntax:	{label:}	SLM{.}	Ws,	Wb,	Wnd				
			[Ws],						
			[Ws++],						
			[Ws--],						
			[++Ws],						
			[--Ws],						
Operands:	Ws ∈ [W0 ... W15]; Wb ∈ [W0 ... W15]; Wnd ∈ [W0 ... W13]								
Operation:	Wb[15:0] → Shift_Val 0 → Left shift input 32'b0, Ws[31:0] → Shift_In[63:0] Shift left Shift_In[63:0] by Shift_Val → Shift_Out[63:0] Shift_Out[31:0] → Wnd Shift_Out[63:32] Wnd+1 → Wnd+1								
Status Affected:	Z								
Encoding:	1110	001U	ssss	dddd	pppU	UUww	wwUU	1011	
Description:	<p>Shift left the contents of the source register Ws by Wb bits, placing the result in the destination register Wnd. The register containing the next most significant data word will already contain an intermediate shift result. Bitwise OR this value with the data shifted out of Ws in order to create the final shift result, then update the corresponding destination register.</p> <p>The left shift may be by any amount between 0 and 32 bits. Should the shift value held in Wb[15:0] exceed 2'd32, the shift value will saturate to 2'd32 for consistency. Any data held in Wb[31:16] will have no effect.</p> <p>This instruction is intended to be used in conjunction with the SLW instruction to support multi-precision multi-bit shift operations.</p> <p>The Z bit is "sticky" (can only be cleared).</p> <p>The 'w' bits select the base (shift count) register.</p> <p>The 's' bits select the source register.</p> <p>The 'd' bits select the destination register.</p> <p>The 'p' bits select the source addressing mode.</p> <p>Note: This instruction operates in Long Word mode only.</p>								
I-Words:	1								
Cycles:	2								

SQR		Square to Accumulator						
Syntax: {label}	SQR{.w} SQR.l	Wx, [Wx], [Wx]+=kx, [Wx]-=kx, [Wx+=kx], [Wx-=kx], [Wx+W12],	A B		{,AWB}			
Operands:	Wx ∈ {W0 ... W15}; Word mode: kx ∈ {-8, -6, -4, -2, 2, 4, 6, 8}; Long Word mode: kx ∈ {-16, -12, -8, -4, 4, 8, 12, 16}; AWB ∈ {W0, W1, W2, W3, W13, [W13++], [W15++] ⁵ }							
Operation:	(Wx) ² → ACC(A or B); (ACC(B or A)) rounded → AWB When Indirect Pre/Post Modification Addressing: (Wx)+kx→Wx or (Wx)-kx→Wx;							
Status Affected:	OA,SA or OB,SB							
Encoding:	1101	01AL	www	ssss	IIIi	i110	UUaa	a011
Description:	Instruction to compute (A) ² functions. Signed or unsigned (defined by CORCON.US) square of data read from Wx or fetched from the X address space. Note that, because only one operand is required, DS is not split into the X and Y address space for concurrent read access, so X-space in this instruction represents all of available DS (which will include Y-space). The result is sign-extended or zero-extended to 72-bits then written to the specified accumulator. Fractional results are also scaled prior to the accumulator update to align the operand and accumulator (msw) fractional points. When Indirect Pre/Post Modified Addressing is selected, the address modifier value is kx, and represents the number of data bytes by which to modify the Effective Address. The optional AWB specifies the direct or indirect store of the (32-bit) rounded fractional contents of the accumulator not targeted by the SQR operation. Rounding mode is defined by CORCON.RND. Write data width is determined by selected instruction data size (see note 4). AWB is not intended for use when the DSP engine is operating in Integer mode. Data read may be 16-bit or 32-bit values. All indirect address modification is scaled accordingly. The 'L' bit selects word or long word operation. The 'A' bit selects the accumulator for the result. The 'I' bits select the Operation.Addressing mode. The 'i' bits select the kx modification value. The 's' bits select Wx, data register or X-space source address register. The 'w' bits are to be a copy of the 's' bits. The 'a' bits select the accumulator write-back destination and addressing mode.							
	Notes:							
	1. Operates in Fractional or Integer Data mode as defined by CORCON.IF. 2. Operands are always regarded as signed or unsigned based on the state of CORCON.US. 3. Use of the same W-reg for both indirect source and AWB indirect destination is not permitted if the source is a pre- or post-modified Effective Address. 4. Stack must remain long word aligned. Consequently, [W15++] AWB is only permitted for use with long word MAC-class instructions.							
I-Words:	1							
Cycles:	1							
Example:1	SQR.l	[w9]+=4, A	;Square the value stored in address contained by w9; store the results in ACCA and increment w9 by 4					
	Before execution				After execution			

Instruction Descriptions (N to XORWF) (continued)

Example:1	SQR.l	[w9] += 4, A	;Square the value stored in address contained by w9; ;store the results in ACCA and increment w9 by 4	
	ACCA	0x00_7022_2EE1_5633_9078	ACCA	0x00_1000_0000_000_0000
	w9	0x5000	w9	0x5000
	Data @5000	0x20000000	Data @5000	0x20000000

SQRAC	Square and Accumulate			
Syntax: {label}	SQRAC{.w} Wx, SQRAC.I [Wx], [Wx]+=kx, [Wx]-=kx, [Wx+=kx], [Wx-=kx], [Wx+W12],	A B		{,AWB}
Operands:	Wx ∈ {W0 ... W15}; Word mode: kx ∈ {-8, -6, -4, -2, 2, 4, 6, 8}; Long Word mode: kx ∈ {-16, -12, -8, -4, 4, 8, 12, 16}; AWB ∈ {W0, W1, W2, W3, W13, [W13++], [W15++] ⁵ }			
Operation:	ACC(A or B) + (Wx) ² → ACC(A or B); (ACC(B or A) rounded) → AWB When Indirect Pre/Post Modification Addressing: (Wx)+kx→Wx or (Wx)-kx→Wx;			
Status Affected:	OA,SA or OB,SB			
Encoding:	1101	00AL	www	ssss IIIi i110 UUaa a011
Description:	<p>Instruction to compute Accumulator + (A)² functions. Signed or unsigned (defined by CORCON.US) square of data read from Wx or fetched from the X address space. Note that, because only one operand is required, DS is not split into X and Y address space for concurrent read access, so X-space in this instruction represents all of the available DS (which will include Y-space). The result is sign-extended or zero-extended to 72-bits then added to the specified accumulator. Fractional or integer operation (defined by CORCON.IF) will determine if the result is scaled or not prior to the accumulator update. Fractional operation will scale the result to align the operand and accumulator (msw) fractional points (see note 3). Integer operation will align the LSb of the result with the LSb of the accumulator.</p> <p>When indirect pre/post modified addressing is selected, the address modifier value is kx and represents the number of data bytes by which to modify the Effective Address.</p> <p>The optional AWB specifies the direct or indirect (see note 4) store of the (32-bit) rounded fractional contents of the accumulator not targeted by the SQRAC operation. Rounding mode is defined by CORCON.RND. Write data width is determined by selected instruction data size. AWB is not intended for use when the DSP engine is operating in Integer mode.</p> <p>Data read may be 16-bit or 32-bit values. All indirect address modification is scaled accordingly.</p> <p>The 'L' bit selects word or long word operation.</p> <p>The 'A' bit selects the accumulator for the result.</p> <p>The 'I' bits select the Operation.Addressing mode.</p> <p>The 'i' bits select the kx modification value.</p> <p>The 's' bits select Wx, data register or X-space source address register.</p> <p>The 'w' bits are to be a copy of the 's' bits.</p> <p>The 'a' bits select the accumulator write-back destination and addressing mode.</p> <p>Notes:</p> <ol style="list-style-type: none"> Operates in Fractional or Integer Data mode as defined by CORCON.IF. Operands are always regarded as signed or unsigned based on the state of CORCON.US. The LS portion of ACCx is unaffected when operating in Fractional mode with word sized data. Lower significance data that may be present from prior (32-bit data) operations is therefore preserved. Users not requiring this should clear ACCx during initialization. Use of the same W-reg for both indirect source and AWB indirect destination is not permitted if the source is a pre- or post-modified Effective Address. Stack must remain long word aligned. Consequently, [W15++] AWB is only permitted for use with long word MAC-class instructions. 			
I-Words:	1			
Cycles:	1			

Example:1 **SQRAC.l [w9] +=4, A** **;Square the value stored in address contained by w9; ;accumulate the results to ACCA and increment w9 by 4**

Before execution		After execution	
ACCA	0x00_4000_0000_000_0000	ACCA	0x00_5000_0000_000_0000
w9	0x5000	w9	0x5000
Data @5000	0x20000000	Data @5000	0x20000000

SQRN		Negated Square to Accumulator	
Syntax: {label}	SQRN{.w} Wx, A {,AWB}	SQRN.L [Wx], B	
		[Wx]+=kx,	
		[Wx]-=kx,	
		[Wx+=kx],	
		[Wx-=kx],	
		[Wx+W12],	
Operands:	Wx ∈ {W0 ... W15}; Word mode: kx ∈ {-8, -6, -4, -2, 2, 4, 6, 8}; Long Word mode: kx ∈ {-16, -12, -8, -4, 4, 8, 12, 16}; AWB ∈ {W0, W1, W2, W3, W13, [W13++], [W15++] ⁵ }		
Operation:	-(Wx) ² → ACC(A or B); (ACC(B or A)) rounded → AWB When Indirect Pre/Post Modification Addressing: (Wx)+kx→Wx or (Wx)-kx→Wx;		
Status Affected:	OA,SA or OB,SB		
Encoding:	1101	01AL	www ssss IIIi i110 UUaa a111
Description:	<p>Instruction to compute -(A)² functions. Signed or unsigned (defined by CORCON.US) square of data read from Wx or fetched from the X address space. Note that, because only one operand is required, DS is not split into X and Y address space for concurrent read access, so X-space in this instruction represents all of the available DS (which will include Y-space).</p> <p>The result is sign-extended or zero-extended to 72-bits, negated and then written to the specified accumulator. Fractional results are also scaled prior to the accumulator update to align the operand and accumulator (msw) fractional points. For word sized operand operations, when Indirect Pre/Post Modified Addressing is selected, the address modifier value is kx and represents the number of data bytes by which to modify the Effective Address.</p> <p>The optional AWB specifies the direct or indirect (see note 3) store of the (32-bit) rounded fractional contents of the accumulator not targeted by the SQRN operation. Rounding mode is defined by CORCON.RND. Write data width is determined by selected instruction data size (see note 4). AWB is not intended for use when the DSP engine is operating in Integer mode.</p> <p>Data read may be 16-bit or 32-bit values. All indirect address modification is scaled accordingly.</p> <p>The 'L' bit selects word or long word operation.</p> <p>The 'A' bit selects the accumulator for the result.</p> <p>The 'I' bits select the Operation.Addressing mode.</p> <p>The 'I' bits select the kx modification value.</p> <p>The 's' bits select Wx, data register or X-space source address register.</p> <p>The 'w' bits are to be a copy of the 's' bits.</p> <p>The 'a' bits select the accumulator write-back destination and addressing mode.</p> <p>Notes:</p> <ol style="list-style-type: none"> Operates in Fractional or Integer Data mode as defined by CORCON.IF. Use of the same W-reg for both indirect source and AWB indirect destination is not permitted if the source is a pre- or post-modified Effective Address. Use of the same W-reg for both indirect source and AWB indirect destination is not permitted if the source is a pre- or post-modified Effective Address. Stack must remain long word aligned. Consequently, [W15++] AWB is only permitted for use with long word MAC-class instructions. 		
I-Words:	1		
Cycles:	1		
Example:1	SQRN.L	[w9]+=4, A	;Square the value stored in address contained by w9; store the results in ACCA and increment w9 by 4
	Before execution		After execution

Instruction Descriptions (N to XORWF) (continued)

Example:1	SQRN.I	[w9] += 4, A	;Square the value stored in address contained by w9; ;store the results in ACCA and increment w9 by 4	
	ACCA	0x00_4000_0000_0000_0000	ACCA	0xFF_F000_0000_0000_0000
	w9	0x5000	w9	0x5000
	Data @5000	0x20000000	Data @5000	0x20000000

SQRSC		Square and Subtract from Accumulator			
Syntax: {label}	SQRSC{.w} Wx, A {,AWB}				
	SQRSC.l [Wx], B				
	[Wx]+=kx,				
	[Wx]-=kx,				
	[Wx+=kx],				
	[Wx-=kx],				
	[Wx+W12],				
Operands:	Wx ∈ {W0 ... W15}; Word mode: kx ∈ {-8, -6, -4, -2, 2, 4, 6, 8}; Long Word mode: kx ∈ {-16, -12, -8, -4, 4, 8, 12, 16}; AWB ∈ {W0, W1, W2, W3, W13, [W13++], [W15++] ⁵ }				
Operation:	ACC(A or B) - (Wx) ² → ACC(A or B); (ACC(B or A)) rounded → AWB When Indirect Pre/Post Modification Addressing: (Wx)+kx→Wx or (Wx)-kx→Wx;				
Status Affected:	OA,SA or OB,SB				
Encoding:	1101 00AL www ssss IIIi i110 UUaa a111				
Description:	Instruction to compute Accumulator - (A) ² functions. Signed or unsigned (defined by CORCON.US) square of data read from Wx or fetched from the X address space. Note that, because only one operand is required, DS is not split into X and Y address space for concurrent read access, so X-space in this instruction represents all of the available DS (which will include Y-space). The result is sign-extended or zero-extended to 72-bits then subtracted from the specified accumulator. Fractional or integer operation (defined by CORCON.IF) will determine if the result is scaled or not prior to the accumulator update. Fractional operation will scale the result to align the operand and accumulator (msw) fractional points (see note 4). Integer operation will align the LSb of the result with the LSb of the accumulator. When Indirect Pre/Post Modified Addressing is selected, the address modifier value is kx and represents the number of data bytes by which to modify the Effective Address. The optional AWB specifies the direct or indirect (see note 4) store of the (32-bit) rounded fractional contents of the accumulator not targeted by the SQRSC operation. Rounding mode is defined by CORCON.RND. Write data width is determined by selected instruction data size. AWB is not intended for use when the DSP engine is operating in Integer mode. Data read may be 16-bit or 32-bit values. All indirect address modification is scaled accordingly. The 'L' bit selects word or long word operation. The 'A' bit selects the accumulator for the result. The 'I' bits select the Operation.Addressing mode. The 'i' bits select the kx modification value. The 's' bits select Wx, data register or X-space source address register. The 'w' bits are to be a copy of the 's' bits. The 'a' bits select the accumulator write-back destination and addressing mode. Notes: 1. Operates in Fractional or Integer Data mode as defined by CORCON.IF. 2. Operands are always regarded as signed or unsigned based on the state of CORCON.US. 3. Use of the same W-reg for both indirect source and AWB indirect destination is not permitted if the source is a pre- or post-modified Effective Address. 4. The LS portion of ACCx is unaffected when operating in Fractional mode with word sized data. Lower significance data that may be present from prior (32-bit data) operations is therefore preserved. Users not requiring this should clear ACCx during initialization. 5. Stack must remain long word aligned. Consequently, [W15++] AWB is only permitted for use with long word MAC-class instructions.				
I-Words:	1				
Cycles:	1				

Example:1	SQRSC.l	[w9]+=4, A	;Square the value stored in address contained by w9; ;subtract the results from ACCA and increment w9 by 4
-----------	---------	------------	--

Before execution		After execution	
ACCA	0x00_4000_0000_000_0000	ACCA	0x00_3000_0000_000_0000
w9	0x5000	w9	0x5000
Data @5000	0x20000000	Data @5000	0x20000000

SACR		Store Rounded Accumulator, Literal Shift			
Syntax:	{label:}	SACR{.w} A,	{ Slit6, }	Wd	
		SACR.l	B,	[Wd]	
				[Wd++]	
				[Wd--]	
				[--Wd]	
				[++Wd]	
				[Wd+Wb]	
Operands:		Slit6 ∈ [-32 ... +31]; Wd ∈ [W0 ... W15]; Wb ∈ [W0 ... W15];			
Operation:		<u>For long word operation:</u> Long Word mode: Post-shift(Round{ACC[63:32]}) → Wd[31:0] <u>For word operation:</u> Word mode: Post-shift(Round{ACC[63:48]}) → Wd[15:0] ¹			
Status Affected:		None			
Encoding:	1100	01AL	www	ddd	UUUq qqkk kkkk 1011
Description:		Perform an optional, signed 6-bit shift of the specified accumulator, then store the rounded contents of Acc[63:32] (in case of long-word operation) or Acc[63:48] (in case of word operation) to Wd. The shift range is -32:31, where a negative operand indicates an arithmetic left shift and a positive operand indicates an arithmetic right shift. The Rounding mode (Conventional or Convergent) is set by the RND bit (CORCON<1>). Either Register Direct or Indirect Addressing may be used for Wd. The 'L' bit selects word or long word operation. The 'A' bit specifies the source accumulator. The 'd' bits specify the destination register Wd. The 'q' bits select the destination addressing mode. The 'w' bits specify the offset register Wb. The 'k' bits encode the optional operand Slit6 which determines the amount of the accumulator shift. If operand Slit6 is absent, set literal to all 0's.			
		Notes:			
		1. When the destination is register direct (W-reg), the result is either zero extended (CORCON.US = 1) or sign extended (CORCON.US = 0) to 32 bits. 2. Register direct destination W15 not permitted.			
I-Words:		1			
Cycles:		1			

Example:1 SACR B, #-1, w8 ;word mode;Right shift value of ACCB by 1; store rounded result of shifted value in w8

Before execution		After execution	
ACCB	0x00_1022_2EE1_5 633_9078	ACCB	0x00_1022_2EE1_5 633_9078
w8	0x00000000	w8	0x00007022

Example:2 SACR.l A, #1, w8 ;long-word mode;Right shift value of ACCA by 1; store rounded result of shifted value in w8

Before execution		After execution	
ACCA	0x00_7022_2EE1_5 633_9078	ACCA	0x00_7022_2EE1_5 633_9078
w8	0x00000000	w8	0x70222EE1

SACR		Store Rounded Accumulator after Shift						
Syntax:	{label:}	SACR{.w} A,	Ws,	Wd				
		SACR.l B,		[Wd]				
				[Wd++]				
				[Wd--]				
				[--Wd]				
				[++Wd]				
				[Wd+Wb]				
Operands:		Ws ∈ [W0 ... W15]; Wd ∈ [W0 ... W15] (see note 2); Wb ∈ [W0 ... W15];						
Operation:		<p><u>For long word operation:</u> Long Word mode: Post-shift(Round{ACC[63:32]}) → Wd[31:0]</p> <p><u>For word operation:</u> Word mode: Post-shift(Round{ACC[63:48]}) → Wd[15:0] ¹</p>						
Status Affected:		None						
Encoding:	1100	10AL	www	ddd	UUUq	qqss	ssUU	0111
Description:		<p>Perform an optional, signed 6-bit shift of the specified accumulator, then store the rounded contents of Acc[63:32] (in case of long-word operation) or Acc[63:48] (in case of word operation) to Wd. The shift range is sourced from the signed contents of Ws[5:0], values in the range of -32:31, where a negative value indicates an arithmetic left shift and a positive value indicates an arithmetic right shift. The Rounding mode (Conventional or Convergent) is set by the RND bit (CORCON<1>). Either Register Direct or Indirect Addressing may be used for Wd. If Ws is out of range (that is., Ws[31:5] not equal to all 1's or all 0's), a math error trap will be requested during execution. The instruction will continue to execute based on the value held in Ws[5:0].</p> <p>After the shift, a word operation (SACR.w) assumes that the value is a Q1.15 signed fraction. Accordingly, a round into shift result bit 48 is executed and shift result [63:48] is then written to the Effective Address.</p> <p>After the shift, a long word operation (SACR.l) assumes that the value is a Q1.31 signed fraction. Accordingly, a round into shift result bit 32 is executed and shift result [63:32] is then written to the Effective Address.</p> <p>The 'L' bit selects word or long word operation. The 'A' bit specifies the source accumulator. The 'd' bits specify the destination register Wd. The 's' bits specify the shift value source register Ws. The 'q' bits select the destination addressing mode. The 'w' bits specify the offset register Wb. See for modifier addressing information.</p> <p>Notes:</p> <ol style="list-style-type: none"> When the destination is register direct (W-reg), the result is either zero extended (CORCON.US = 1) or sign extended (CORCON.US = 0) to 32-bits. Register direct destination W15 not permitted. 						
I-Words:		1						
Cycles:		1						

Example:1 SACR.l A, W9, w8 ;Right shift value of ACCA by content in w9; store rounded result of shifted value in w8

		Before execution		After execution	
ACCA		0x00_7022_2EE1_5		ACCA	0x00_7022_2EE1_5
		633_9078			633_9078
w8		0x00000000		w8	0x70222EE1
w9		0x1		w9	0x1

SUAC		Store Upper Accumulator					
Syntax:	{label:}	SUAC{.I}	A,	{ Slit6 , }	Wd		
			B,		[Wd]		
					[Wd++]		
					[Wd--]		
					[--Wd]		
					[++Wd]		
					[Wd+Wb]		
Operands:	Slit6 ∈ [-32 ... +31]; Wd ∈ [W0 ... W15] (see note 2); Wb ∈ [W0 ... W15]						
Operation:	Shift _{Slit6} (ACC) (24{ACC[71]}, ACC[71:64]) → Wd[31:0]						
Status Affected:	None						
Encoding:	1100	01A1	www	ddd	UUUq	qqkk	kkkk 1111
Description:	<p>Read then optionally shift accumulator value, then store the post-shifted upper byte (ACC[71:64]) to the destination Effective Address. Any shift will apply only to data read from the accumulator so will therefore not modify the accumulator contents. The shift value is sourced from a signed literal value.</p> <p>When the destination is register direct (W-reg), the byte result is either zero extended (CORCON.US = 1) or sign extended (CORCON.US = 0) to 32 bits prior to the write.</p> <p>The 'A' bit specifies the source accumulator.</p> <p>The 'd' bits specify the destination register Wd.</p> <p>The 'q' bits select the destination addressing mode.</p> <p>The 'w' bits specify the offset register Wb.</p> <p>The 'k' bits encode the optional operand Slit6 which determines the amount of the accumulator shift. If operand Slit6 is absent, set literal to all 0's.</p> <p>Notes:</p> <ol style="list-style-type: none"> Positive values of operand Slit6 represent arithmetic shift right. Negative values of operand Slit6 represent shift left. Register direct destination W15 not permitted. 						
I-Words:	1						
Cycles:	1						
Example:1	SACR.I	A, W9, w8	;Right shift value of ACCA by content in w9 ; Store ACCAU to w8				

Before execution

ACCA 0xC1_1022_2EE1_5
633_9078

w8 0x12345678

After execution

ACCA 0xC1_1022_2EE1_5
633_9078

w8 0xFFFFFFFF

SUB		Subtract Ws from Wb							
Syntax:	{label:}	SUB.b	Wb,	Ws,	Wd				
		SUB.bz		[Ws],	[Wd]				
		SUB{.w}		[Ws++],	[Wd++]				
		SUB.l		[Ws--],	[Wd--]				
				[++Ws],	[++Wd]				
				[--Ws],	[--Wd]				
Operands:		Wb ∈ [W0 ... W15]; Ws ∈ [W0 ... W15]; Wd ∈ [W0 ... W15]							
Operation:		(Wb) - (Ws) → Wd							
Status Affected:		C, N, OV, Z							
Encoding:		S110	010L	dddd	ssss	pppq	qqww	wwUU	BU00
Description:		Subtract the contents of the source register Ws from the contents of the base register Wb and place the result in the destination register Wd. The 'S' bit selects instruction size. The 'L' and 'B' bits select operation data width. The 's' bits select the source register. The 'w' bits select the base register. The 'd' bits select the destination register. The 'p' bits select the source addressing mode. The 'q' bits select the destination addressing mode.							
I-Words:		1 or 0.5							
Cycles:		1							

```

Example 1:      SUB.B W0, W1, W0                                ; Sub. W1 from W0 (Byte mode)
                                                           ; Store result to W0
    
```

Before Instruction		After Instruction		
W0	1732	W0	17EE	
W1	7844	W1	7844	
SR	0000	SR	0108	(DC, N = 1)

```

Example 2:      SUB W7, [W8++], [W9++]                        ; Sub. [W8] from W7 (Word mode)
                                                           ; Store result to [W9]
                                                           ; Post-increment W8
                                                           ; Post-increment W9
    
```

Before Instruction		After Instruction		
W7	2450	W7	2450	
W8	1808	W8	180A	
W9	2020	W9	2022	
Data 1808	92E4	Data 1808	92E4	
Data 2020	A557	Data 2020	916C	
SR	0000	SR	010C	(DC, N, OV = 1)

SUB Signed Subtract from Accumulator

Syntax: {label:} SUB{.w} Ws, { Slit6, } A
 SUB.l [Ws], B
 [Ws++]
 [Ws--]
 [--Ws],
 [++Ws],
 [Ws+Wb],

Operands: Ws ∈ [W0 ... W15]; Wb ∈ [W0 ... W15]; Slit6 ∈ [-32 ... +31]

Operation: (ACC) - Shift_{Slit6}(Sign-extend(Ws)) → ACC

Status Affected: OA, SA or OB, SB

Encoding: 1100 00AL www ssss ppU UUkk kkkk 1111

Description: The operand contained at the Effective Address is assumed to be Q1.15 or Q1.31 fractional data for word and long data operations, respectively. The operand is read, then automatically sign-extended and zero-backfilled to create a value the same size as the accumulator. The value is then optionally (arithmetically) shifted before being subtracted from the target accumulator.

The 'L' bit selects word or long word operation.

The 'A' bit specifies the destination accumulator.

The 's' bits specify the source register Ws.

The 'p' bits select the source addressing mode.

The 'w' bits specify the offset register Wb.

The 'k' bits encode the optional operand Slit6 which determines the amount of the accumulator preshift; if the operand Slit6 is absent, the literal bit field is set to all 0's.

Notes:

1. Positive values of operand Slit6 represent arithmetic shift right. Negative values of operand Slit6 represent shift left.
2. This instruction operates in Long or Word mode only.

I-Words: 1

Cycles: 1

Example:1 SUB w8, #1, B ;ACCB = ACCB - (w8>>1):32'b0

Before execution		After execution	
w8	0x20446326	w8	0x20446326
ACCB	0x00_2044_6326_4 112_9403	ACCB	0x00_1022_3193_4 112_9403

Example:2 SUB A ;ACCA = ACCA - ACCB ; CORCON = 0x0000 (no saturation)

Before execution		After execution	
ACCA	0x76_120F_098A _1212_4593	ACCA	0x52_CC7B_E05 5_7FDD_B56A
ACCB	0x23_4593_2934 _9234_9029	ACCB	0x23_4593_2934 _9234_9029
CORCON	0x00000000	CORCON	0x00000000
SR[15:8]	8'b00000000	SR[15:8]	8'b11000000 (OA/OB = 1)

Example:3 SUB B ;ACCB = ACCB - ACCA ; CORCON = 0x0000 (no saturation)

Instruction Descriptions (N to XORWF) (continued)

Example:3	SUB	B	;ACCB = ACCB - ACCA ; CORCON = 0x0000 (no saturation)
-----------	-----	---	--

Before execution		After execution	
ACCA	0xFF_9022_2EE1_5633_9078	ACCA	0xFF_9022_2EE1_5633_9078
ACCB	0x00_2456_8F4C_0922_1245	ACCB	0x00_7FFF_FFFF_FFFF_FFFF
CORCON	0x00000040	CORCON	0x00000040 (SATB)
SR[15:8]	8'b00000000	SR[15:8]	8'b00010100 (SB/SAB = 1)

SUBB		Subtract Ws from Wb with Borrow			
Syntax:	{label:}	SUBB.b	Wb,	Ws,	Wd
		SUBB.bz		[Ws],	[Wd]
		SUBB{.w}		[Ws++],	[Wd++]
		SUBB.l		[Ws--],	[Wd--]
				[++Ws],	[++Wd]
				[--Ws],	[--Wd]
Operands:	Wb ∈ [W0 ... W15]; Ws ∈ [W0 ... W15]; Wd ∈ [W0 ... W15]				
Operation:	(Wb) - (Ws) - (C) → Wd				
Status Affected:	C, N, OV, Z				
Encoding:	S110	011L	dddd	ssss	pppq qqww wwUU BU00
Description:	<p>Subtract the contents of the source register Ws and the Carry flag from the contents of the base register Wb and place the result in the destination register Wd.</p> <p>The Z bit is “sticky” (can only be cleared).</p> <p>The ‘S’ bit selects instruction size .</p> <p>The ‘L’ and ‘B’ bits select operation data width.</p> <p>The ‘s’ bits select the source register.</p> <p>The ‘w’ bits select the base register.</p> <p>The ‘d’ bits select the destination register.</p> <p>The ‘p’ bits select the source addressing mode.</p> <p>The ‘q’ bits select the destination addressing mode.</p>				
I-Words:	1 or 0.5				
Cycles:	1				

Examp le 1: `SUBB.B W0, W1, W0` ; Sub. W1 and C from W0 (Byte mode)
; Store result to W0

Before Instruction		After Instruction	
W0	1732	W0	17ED
W1	7844	W1	7844
SR	0000	SR	0108 (DC, N = 1)

Example 2: `SUBB W7, [W8++], [W9++]` ; Sub. [W8] and C from W7 (Word mode)
; Store result to [W9]
; Post-increment W8
; Post-increment W9

Before Instruction		After Instruction	
W7	2450	W7	2450
W8	1808	W8	180A
W9	2022	W9	2024
Data 1808	92E4	Data 1808	92E4
Data 2022	A557	Data 2022	916B
SR	0000	SR	010C (DC, N, OV = 1)

SUBB		Subtract Short Literal from Ws with Borrow			
Syntax:	{label:}	SUBB.b	Ws,	lit7,	Wd
		SUBB.bz	[Ws],		[Wd]
		SUBB{.w}	[Ws++],		[Wd++]
		SUBB.l	[Ws--],		[Wd--]
			[++Ws],		[++Wd]
			[--Ws],		[--Wd]
Operands:	Ws ∈ [W0 ... W15]; lit7 ∈ [0 ... 127]; Wd ∈ [W0 ... W15]				
Operation:	(Ws) - lit7 - (C) → Wd Note: The literal is zero-extended to the selected data size of the operation				
Status Affected:	C, N, OV, Z				
Encoding:	1110	011L	dddd	ssss	pppq qqkk kkkk Bk10
Description:	<p>Subtract the zero-extended unsigned literal operand and the Carry bit from the contents of the source register Ws, and place the result in the destination register Wd. The Z bit is “sticky” (can only be cleared). The ‘L’ and ‘B’ bits select operation data width. The ‘k’ bits provide the literal operand (MSb in op[2]). The ‘s’ bits select the source register. The ‘d’ bits select the destination register. The ‘p’ bits select the source addressing mode. The ‘q’ bits select the destination addressing mode.</p>				
I-Words:	1				
Cycles:	1				

SUBB		Subtract Literal from Wn with Borrow			
Syntax:	{label:}	SUBB.b	lit16,	Wn	
		SUBB.bz			
		SUBB{.w}			
		SUBB.l			
Operands:	lit16 ∈ [0 ... 65535]; Wn ∈ [W0 ... W15]				
Operation:	(Wn) - lit16 - (C) → Wn				
	Note: The literal is zero-extended to the selected data size of the operation				
Status Affected:	C, N, OV, Z				
Encoding:	1100	011L	ssss	kkkk	kkkk
				kkkk	kkkk
					B010
Description:	<p>Subtract the zero-extended literal operand and the Carry bit from the contents of the Working register Wn, and place the result in the Working register Wn.</p> <p>In Byte mode, only the LSb of Wn is written. In Word mode, the word result is zero-extended to 32-bits and written to Wn.</p> <p>The Z bit is "sticky" (can only be cleared).</p> <p>The 'L' and 'B' bits select operation data width.</p> <p>The 's' bits select the Working register.</p> <p>The 'k' bits specify the literal operand.</p>				
I-Words:	1				
Cycles:	1				

SUBBR		Subtract f and Carry bit from Wn							
Syntax:	{label:}	SUBBR.b f	,Wn	{,WREG}					
		SUBBR.bz							
		SUBBR{.w}							
		SUBBR.l							
Operands:		f ∈ [0 ... 64KB]; Wn ∈ [W0 ... W15]							
Operation:		(Wn) - (f) - (C) → destination designated by D							
Status Affected:		C, N, OV, Z							
Encoding:		1110	011L	ssss	ffff	ffff	ffff	ffff	BD01
Description:		<p>Subtract the contents of the file register and the Carry bit from the contents of the Working register and place the result in the destination designated by D. If the optional Wn is specified, D=0 and store result in Wn; otherwise, D=1 and store result in the file register.</p> <p>The Z bit is “sticky” (can only be cleared).</p> <p>The ‘L’ and ‘B’ bits select operation data width.</p> <p>The ‘D’ bit selects the destination.</p> <p>The ‘f’ bits select the address of the file register.</p> <p>The ‘s’ bits select the Working register.</p>							
I-Words:		1							
Cycles:		1							

SUBBR		Subtract Ws from Short Literal with Borrow			
Syntax:	{label:}	SUBBR.b	Ws,	lit7	Wd
		SUBBR.bz	[Ws],		[Wd]
		SUBBR{.w}	[Ws++],		[Wd++]
		SUBBR.l	[Ws--],		[Wd--]
			[++Ws],		[++Wd]
			[--Ws],		[--Wd]
Operands:	Ws ∈ [W0 ... W15]; lit7 ∈ [0 ... 127; Wd ∈ [W0 ... W15]				
	Note: The literal is zero-extended to the selected data size of the operation				
Operation:	lit7 - (Ws) - (C) → Wd				
Status Affected:	C, N, OV, Z				
Encoding:	1110	111L	dddd	ssss	pppq qqkk kkkk Bk10
Description:	<p>Subtract the contents of the source register Ws and the Carry flag from the zero-extended unsigned literal, and place the result in the destination register Wd.</p> <p>The Z bit is “sticky” (can only be cleared).</p> <p>The ‘L’ and ‘B’ bits select operation data width.</p> <p>The ‘k’ bits provide the literal operand (MSb in op[2]).</p> <p>The ‘s’ bits select the source register.</p> <p>The ‘d’ bits select the destination register.</p> <p>The ‘p’ bits select the source addressing mode.</p> <p>The ‘q’ bits select the destination addressing mode.</p>				
I-Words:	1				
Cycles:	1				

SUBB		Subtract Wn and Carry bit from f							
Syntax:	{label:}	SUBB.b	f	,Wn	{,WREG}				
		SUBB.bz							
		SUBB{.w}							
		SUBB.l							
Operands:		f ∈ [0 ... 64KB]; Wn ∈ [W0 ... W15]							
Operation:		(f) - (Wn) - (C) → destination designated by D							
Status Affected:		C, N, OV, Z							
Encoding:		1110	111L	ssss	ffff	ffff	ffff	ffff	BD01
Description:		<p>Subtract the contents of the Working register and the Carry bit from the contents of the file register, and place the result in the destination designated by D. If the optional Wn is specified, D=0 and store result in Wn; otherwise, D=1 and store result in the file register.</p> <p>The Z bit is “sticky” (can only be cleared).</p> <p>The ‘L’ and ‘B’ bits select operation data width.</p> <p>The ‘D’ bit selects the destination.</p> <p>The ‘f’ bits select the address of the file register.</p> <p>The ‘s’ bits select the Working register.</p>							
I-Words:		1							
Cycles:		1							

SUB		Subtract f from Wn							
Syntax:	{label:}	SUBR.b	f	,Wn	{,WREG}				
		SUBR.bz							
		SUBR{.w}							
		SUBR.l							
Operands:		f ∈ [0 ... 64KB]; Wn ∈ [W0 ... W15]							
Operation:		(Wn) - (f) → destination designated by D							
Status Affected:		C, N, OV, Z							
Encoding:		1110	010L	ssss	ffff	ffff	ffff	ffff	BD01
Description:		Subtract the contents of the file register from the contents of the Working register, and place the result in the destination designated by D. If the optional Wn is specified, D=0 and store result in Wn; otherwise, D=1 and store result in the file register. The 'L' and 'B' bits select operation data width. The 'D' bit selects the destination. The 'f' bits select the address of the file register. The 's' bits select the Working register.							
I-Words:		1							
Cycles:		1							

SUB		Subtract Short Literal from Wn			
Syntax:	{label;} SUB.l lit5, Wn				
Operands:	lit5 ∈ [0 ... 31]; Wn ∈ [W0 ... W15]				
Operation:	(Wn) - lit5 → Wn				
Status Affected:	C, N, OV, Z				
Encoding:	0111	011k	kkkk	ssss	
Description:	<p>Subtract the zero-extended literal operand from the contents of the Working register and place the result in the Working register Wn. If literal >31 and/or word or byte operation is required, assemble as SUBLW instruction.</p> <p>The 's' bits select the Working register.</p> <p>The 'k' bits specify the literal operand.</p>				
I-Words:	0.5				
Cycles:	1				

SUB		Subtract Short Literal from Ws			
Syntax:	{label:}	SUB.b	Ws,	lit7,	Wd
		SUB.bz	[Ws],		[Wd]
		SUB{.w}	[Ws++],		[Wd++]
		SUB.l	[Ws--],		[Wd--]
			[++Ws],		[++Wd]
			[--Ws],		[--Wd]
Operands:	Ws ∈ [W0 ... W15]; lit7 ∈ [0 ... 127]; Wd ∈ [W0 ... W15]				
Operation:	(Ws) - lit7 → Wd				
	Note: The literal is zero-extended to the selected data size of the operation				
Status Affected:	C, N, OV, Z				
Encoding:	1110	010L	dddd	ssss	pppq qqkk kkkk Bk10
Description:	Subtract the zero-extended unsigned literal operand from the contents of the source register Ws, and place the result in the destination register Wd. The 'L' and 'B' bits select operation data width. The 'k' bits provide the literal operand (MSb in op[2]). The 's' bits select the source register. The 'd' bits select the destination register. The 'p' bits select the source addressing mode. The 'q' bits select the destination addressing mode.				
I-Words:	1				
Cycles:	1				

SUB		Subtract Literal from Wn						
Syntax:	{label:}	SUB.b	lit16,	Wn				
		SUB.bz						
		SUB{.w}						
		SUB.l						
Operands:	lit16 ∈ [0 ... 65535]; Wn ∈ [W0 ... W15]							
Operation:	(Wn) - lit16 → Wn							
Status Affected:	C, N, OV, Z							
Encoding:	1100	010L	ssss	kkkk	kkkk	kkkk	kkkk	B010
Description:	Subtract the zero-extended literal operand from the contents of the Working register, and place the result in the Working register Wn. If literal ≤ 31 and long operation is required, assemble as SUBLN instruction. The 'L' and 'B' bits select operation data width. The 's' bits select the Working register. The 'k' bits specify the literal operand.							
I-Words:	1							
Cycles:	1							

Example 1: `SUB.B #0x23, W0` ; Sub. 0x23 from W0 (Byte mode)
; Store result to W0

Before Instruction		After Instruction		
W0	7804	W0	78E1	
SR	0000	SR	0008	(N = 1)

Example 2: `SUB #0x108, W4` ; Sub. 0x108 from W4 (Word mode)
; Store result to W4

Before Instruction		After Instruction		
W4	6234	W4	612C	
SR	0000	SR	0001	(C = 1)

SUBR		Subtract Wb from Ws			
Syntax:	{label:}	SUBR.b	Wb,	Ws,	Wd
		SUBR.bz		[Ws],	[Wd]
		SUBR{.w}		[Ws++],	[Wd++]
		SUBR.l		[Ws--],	[Wd--]
				[++Ws],	[++Wd]
				[--Ws],	[--Wd]
Operands:	Wb ∈ [W0 ... W15]; Ws ∈ [W0 ... W15]; Wd ∈ [W0 ... W15]				
Operation:	(Ws) - (Wb) → Wd				
Status Affected:	C, N, OV, Z				
Encoding:	S110	110L	dddd	ssss	pppq qqww wwUU BU00
Description:	Subtract the contents of the base register Wb from the contents of the source register Ws, and place the result in the destination register Wd. The 'S' bit selects instruction size. The 'L' and 'B' bits select operation data width. The 's' bits select the source register. The 'w' bits select the base register. The 'd' bits select the destination register. The 'p' bits select the source addressing mode. The 'q' bits select the destination addressing mode.				
I-Words:	1 or 0.5				
Cycles:	1				

```

Example 1:      SUBR.B W0, W1, W0                ; Sub. W0 from W1
                                                         ; (Byte mode)
                                                         ; Store result to W0
    
```

Before Instruction		After Instruction		
W0	1732	W0	1712	
W1	7844	W1	7844	
SR	0000	SR	0001	(C = 1)

```

Example 2:      SUBR W7, [W8++], [W9++]        ; Sub. W7 from [W8] (Word mode)
                                                         ; Store result to [W9]
                                                         ; Post-increment W8
                                                         ; Post-increment W9
    
```

Before Instruction		After Instruction		
W7	2450	W7	2450	
W8	1808	W8	180A	
W9	2022	W9	2024	
Data 1808	92E4	Data 1808	92E4	
Data 2022	A557	Data 2022	6E94	
SR	0000	SR	0005	(OV, C = 1)

SUBR		Subtract Ws from Short Literal			
Syntax:	{label:}	SUBR.b	Ws,	lit7,	Wd
		SUBR.bz	[Ws],		[Wd]
		SUBR{.w}	[Ws++],		[Wd++]
		SUBR.l	[Ws--],		[Wd--]
			[++Ws],		[++Wd]
			[--Ws],		[--Wd]
Operands:	Ws ∈ [W0 ... W15]; Wd ∈ [W0 ... W15]; lit7 ∈ [1 ... 63] (see note when lit7 = 0)				
Operation:	lit7 - (Ws) → Wd Note: The literal is zero-extended to the selected data size of the operation				
Status Affected:	C, N, OV, Z				
Encoding:	S111	101L	dddd	ssss	pppq qqkk kkkk Bk00
Description:	Subtract the contents of the source register Ws from the zero-extended unsigned literal, and place the result in the destination register Wd. The 'S' bit selects instruction size. The 'L' and 'B' bits select operation data width. The 'k' bits provide the literal operand (MSb in op[2]). The 's' bits select the source register. The 'd' bits select the destination register. The 'p' bits select the source addressing mode. The 'q' bits select the destination addressing mode.				
I-Words:	1 or 0.5				
Cycles:	1				

SUB		Subtract Wn from f							
Syntax:	{label:}	SUB.b	f	Wn	{,WREG}				
		SUB.bz							
		SUB{.w}							
		SUB.l							
Operands:		f ∈ [0 ... 64KB]; Wn ∈ [W0 ... W15]							
Operation:		(f) - (Wn) → destination designated by D							
Status Affected:		C, N, OV, Z							
Encoding:		1110	110L	ssss	ffff	ffff	ffff	ffff	BD01
Description:		Subtract the contents of the Working register from the contents of the file register, and place the result in the destination designated by D. If the optional Wn is specified, D=0 and store the result in Wn; otherwise, D=1 and store the result in the file register. The 'L' and 'B' bits select operation data width. The 'D' bit selects the destination. The 'f' bits select the address of the file register. The 's' bits select the Working register.							
I-Words:		1							
Cycles:		1							

SWAP	Word, Byte or Nibble Swap Wn
Syntax:	{label:} SWAP.b Wn SWAP.bz SWAP{.w} SWAP.l
Operands:	$Wn \in [W0 \dots W15]$
Operation:	Byte mode: $Wn[7:4] \leftrightarrow Wn[3:0]$ Extended Byte mode: $Wn[7:4] \leftrightarrow Wn[3:0]$; $24'h000000 \rightarrow Wn[31:8]$ Word mode: $Wn[15:8] \leftrightarrow Wn[7:0]$ Long Word mode: $Wn[31:24] \leftrightarrow Wn[7:0]$; $Wn[23:16] \leftrightarrow Wn[15:8]$
Status Affected:	None
Encoding:	1111 011L UUUU ssss UUUU UUUU UUUU B111
Description:	If in Long Word mode, swap bytes in both the msw and lsw of Wn register. If in Word mode, swap bytes in the lsw of Wn register. Wn[31:16] is cleared. If in Extended Byte mode, swap nibbles in the LSB of Wn register. Wn[31:8] is cleared. If in Byte mode, swap nibbles in the LSB of Wn register. Wn[31:8] is unaffected. The 'L' and 'B' bits select operation data width. The 's' bits select the Working register. Long word byte swap is intended for data endian conversion.
I-Words:	1
Cycles:	1

TSTF		Test f and (optionally) Move to Wnd						
Syntax:	{label:}	TST.b	f	{,Wnd}				
		TST.bz						
		TST{.w}						
		TST.l						
Operands:		f ∈ [0 ... 64KB]; Wnd ∈ [W0 ... W14];						
Operation:		(f) → destination designated by D						
Status Affected:		Z, N						
Encoding:		1101	001L	dddd	ffff	ffff	ffff	ffff BD01
Description:		<p>Read and test the contents of the file register. If the optional Wnd is specified (D=0), then store the data read in Wnd. Otherwise, D=1 and the only effect is to modify the status flags (i.e, test file register), and no write occurs.</p> <p>The 'L' and 'B' bits select operation data width.</p> <p>The 'D' bit selects if a data write occurs.</p> <p>The 'f' bits select the address of the file register.</p>						
I-Words:		1						
Cycles:		1						

ULNK		De-allocate Stack Frame	
Syntax:	{label:}	ULNK	
Operands:	None		
Operation:	W14 → W15 (W15) - 4 → W15 (TOS) → W14		
Status Affected:	None		
Encoding:	0111	001U	UUUU 0011
Description:	This instruction de-allocates a stack frame and adjusts the Stack Pointer and Frame Pointer. Note: 1. This instruction operates with long word aligned operands only.		
I-Words:	0.5		
Cycles:	1		

Example 1:	ULNK			;De-allocate stack frame
		Before Instruction	After Instruction	
		W14	0x5004	W14 0x5000
		W15	0x502C	W15 0x5000
		Data @0x5000	0x5000	Data @0x5000 0x5000
		SR[7:0]	8'b00000000	SR[7:0] 8'b00000001

XOR		Exclusive or Wb and Ws			
Syntax:	{label:}	XOR.b	Wb,	Ws,	Wd
		XOR.bz		[Ws],	[Wd]
		XOR{.w}		[Ws++],	[Wd++]
		XOR.l		[Ws--],	[Wd--]
				[++Ws],	[++Wd]
				[--Ws],	[--Wd]
				SR	SR
Operands:	Wb ∈ [W0 ... W15]; Ws ∈ [W0 ... W15]; Wd ∈ [W0 ... W15]				
Operation:	(Wb).XOR.(Ws) → Wd				
Status Affected:	N, Z				
Encoding:	s111	000L	dddd	ssss	pppq qqww wwUU BU00
Description:	<p>Compute exclusive OR of the contents of the source register Ws and the contents of the base register Wb, and place the result in the destination register Wd. The 'S' bit selects instruction size. The 'L' and 'B' bits select operation data width. The 's' bits select the source register. The 'w' bits select the base register. The 'd' bits select the destination register. The 'p' bits select the source addressing mode. The 'q' bits select the destination addressing mode.</p> <p>Notes:</p> <ol style="list-style-type: none"> When the SR is selected, SR data write will take priority over any SR update resulting from the XOR operation. .bz data size/mode is disallowed when writing to the SR. 				
I-Words:	1 or 0.5				
Cycles:	1				

```

Example 1: XOR.B W1, [W5++], [W9++] ; XOR W1 and [W5] (Byte mode)
; Store result to [W9]
; Post-increment W5 and W9
    
```

Before Instruction	After Instruction
W1 AAAA	W1 AAAA
W5 2000	W5 2001
W9 2600	W9 2601
Data 2000 115A	Data 2000 115A
Data 2600 0000	Data 2600 00F0
SR 0000	SR 0008 (N = 1)

```

Example 2: XOR W1, W5, W9 ; XOR W1 and W5 (Word mode)
; Store the result to W9
    
```

Before Instruction	After Instruction
W1 FEDC	W1 FEDC
W5 1234	W5 1234
W9 A34D	W9 ECE8
SR 0000	SR 0008 (N = 1)

XOR		Exclusive Or Ws and Short Literal							
Syntax:	{label:}	XOR.b	Ws,	lit7,	Wd				
		XOR.bz	[Ws],		[Wd]				
		XOR{.w}	[Ws++],		[Wd++]				
		XOR.l	[Ws--],		[Wd--]				
			[++Ws],		[++Wd]				
			[--Ws],		[--Wd]				
			SR		SR				
Operands:		Ws ∈ [W0 ... W15]; lit7 ∈ [0 ... 127]; Wd ∈ [W0 ... W15]							
Operation:		(Ws).XOR.lit7 → Wd							
		Note: The literal is zero-extended to the selected data size of the operation							
Status Affected:		N, Z							
Encoding:		1111	000L	dddd	ssss	pppq	qqkk	kkkk	Bk10
Description:		<p>Compute the exclusive OR of the contents of the source register Ws and the zero-extended literal operand, and place the result in the destination register Wd.</p> <p>The 'L' and 'B' bits select operation data width.</p> <p>The 'k' bits provide the literal operand (MSb in op[2]).</p> <p>The 's' bits select the source register.</p> <p>The 'd' bits select the destination register.</p> <p>The 'p' bits select the source addressing mode.</p> <p>The 'q' bits select the destination addressing mode.</p> <p>Notes:</p> <ol style="list-style-type: none"> When the SR is selected, SR data write will take priority over any SR update resulting from the XOR operation. .bz data size/mode is disallowed when writing to the SR. 							
I-Words:		1							
Cycles:		1							

XOR		Exclusive Or Literal and Wn						
Syntax:	{label:}	XOR.b	lit16,	Wn				
		XOR.bz		SR				
		XOR{.w}						
		XOR.I						
Operands:	lit16 ∈ [0 ... 65535]; Wn ∈ [W0 ... W15]; Status Register (SR)							
Operation:	(Wn) .XOR. lit16 → Wn or (SR) .XOR. lit16 → SR							
Status Affected:	N, Z							
Encoding:	1101	000L	ssss	kkkk	kkkk	kkkk	kkkk	BT10
Description:	<p>Compute the exclusive OR of the zero-extended literal operand and the contents of the Working register Wn or SR, and place the result in the Working register Wn or SR. The 'L' and 'B' bits select operation data width.</p> <p>The 's' bits select the Working register.</p> <p>The 'k' bits specify the literal operand.</p> <p>The 'T' bit selects between Ws (T = 0) and SR (T = 1) target registers.</p> <p>Notes:</p> <ol style="list-style-type: none"> When the SR is selected, SR data write will take priority over any SR update resulting from the XOR operation. .bz data size/mode is disallowed when writing to the SR. 							
I-Words:	1							
Cycles:	1							

Example 1: XOR.B #0x23, W0 ; XOR 0x23 and W0 (Byte mode)
; Store result to W0

Before Instruction	After Instruction
W0 7804	W0 7827
SR 0000	SR 0000

Example 2: XOR #0x108, W4 ; XOR 0x108 and W4 (Word mode)
; Store result to W4

Before Instruction	After Instruction
W4 6134	W4 603C
SR 0000	SR 0000

XOR		Exclusive Or f and Wn							
Syntax:	{label:}	XOR.b	f	,Wn	{WREG}				
		XOR.bz							
		XOR{.w}							
		XOR.l							
Operands:		f ∈ [0 ... 64KB]; Wn ∈ [W0 ... W15]							
Operation:		(f).XOR.(Wn) → destination designated by D							
Status Affected:		N, Z							
Encoding:		1111	000L	ssss	ffff	ffff	ffff	ffff	BD01
Description:		<p>Compute the XOR of the contents of the Working register and the contents of the file register, and place the result in the destination designated by D: If the optional Wn is specified, D=0 and store the result in Wn; otherwise, D=1 and store the result in the file register.</p> <p>The 'L' and 'B' bits select operation data width.</p> <p>The 'D' bit selects the destination.</p> <p>The 'f' bits select the address of the file register.</p> <p>The 's' bits select the Working register.</p>							
I-Words:		1							
Cycles:		1							

ZE		Zero Extend Ws							
Syntax:	{label:}	ZE.bz ZE.w	Ws, [Ws], [Ws++], [Ws--], [++Ws], [--Ws], [Ws+Wb],	Wnd					
Operands:		Ws ∈ [W0 ... W15]; Wb ∈ [W0 ... W15]; Wnd ∈ [W0 ... W14]							
Operation:		If Byte mode: Ws[7:0] → Wd[7:0]; 0 → Wnd[31:8]; If Word mode: Ws[15:0] → Wd[15:0]; 0 → Wnd[31:16];							
Status Affected:		C, N, Z							
Encoding:		S111	111B	dddd	ssss	pppU	UUww	wwUU	UU00
Description:		Zero-extend an 8-bit or 16-bit signed value in Ws to a 32-bit value, then write the result back to Wnd. N is always cleared. C is always set. The 'S' bit selects instruction size. The 'B' bit selects byte or word operation. The 's' bits select the source register. The 'd' bits select the destination register. The 'p' bits select the source addressing mode. The 'w' bits define the offset Wb. Note: 1. This operation always writes a long word.							
I-Words:		1 or 0.5							
Cycles:		1							

Example 1:	ZE.bz	W0, W3	;Zero extend a byte in W0, store it in W3
------------	-------	--------	---

Before Instruction	After Instruction
W0 0x12347879	W0 0x12347879
W3 0x00000000	W3 0x00000079
SR[7:0] 8'b00000000	SR 8'b00000001 (C = 1)

Example 2:	ZE	W0, W3	;Zero extend a word in W0, store it in W3
------------	----	--------	---

Before Instruction	After Instruction
W0 0x12347879	W0 0x12347879
W3 0x00000000	W3 0x00007879
SR[7:0] 8'b00000000	SR[7:0] 8'b00000001 (C = 1)

4.8. FPU Instruction Encoding and Opcode Field Description

Table 4-11. Symbols Used in FPU Instruction Encoding Field Description

Field	Description
lit16	16-bit unsigned literal $\hat{\{0\dots65535\}}$
index	Literal address index into 32 entry SP and DP constant tables
.s	32-bit Single Precision selection
.d	64-bit Double Precision selection
Fd	One of 32 destination floating-point registers $\hat{\{F0..F31\}}$ (Register Direct)
Fb	One of 32 source floating-point registers $\hat{\{F0..F31\}}$ (Register Direct)
Fs	One of 32 source floating-point registers $\hat{\{F0..F31\}}$ (Register Direct)
SUB, INF, FN, FZ, FNAN GT, LT, EQ, UN SUBO, HUGI, INX, UDF, OVF, DIV0, INVAL	FPU status bits (FSR) Note: Flags for exceptions that cannot be signaled by an instruction are always cleared by that instruction (sticky flags are unaffected)

Table 4-12. FPU Instruction Opcode Field Descriptions

Field	Description
P	Selects Single Precision (P=0) or Double Precision (P=1) operation
R	Selects between FPU coprocessor special registers (R=1) or F-regs (R=0)
U	Unused (don't care) instruction bit. Assembler to assign '0'
dddd	R=0: FPU coprocessor Fd destination register select: 00000=F0; 11111=F31 R=1: FPU coprocessor special register select
eee	FPU rounding mode selection
kkkk kkkk kkkk kkkk	16-bit literal field, constant data
ssss	R=0: FPU coprocessor Fs source register select: 00000=F0; 11111=F31 R=1: FPU coprocessor special register select

4.9. Floating-Point Instruction Description

ABS		Absolute value of Fs							
Syntax:	{label:}	ABS.s	Fs,	Fd					
		ABS.d							
Operands (.s):	Fs ∈ [F0 ... F31]; Fd ∈ [F0 ... F31]								
Operands (.d):	Fs ∈ [F0, F2 ... F30]; Fd ∈ [F0, F2 ... F30]								
Operation:	ABS Fs → Fd								
Status Affected:	SUBO								
Exceptions Possible:	SUBO								
Encoding:	1000	100P	zzdd	ddds	ssss	UUUU	UUUU	0010	
Description:	Clear the sign of the contents of the source register Fs, and place the result in the destination register Fd. The 'P' bit selects single (.s) or double precision (.d) operation. The 'z' bits select the target coprocessor. The 's' bits select the source register. The 'd' bits select the destination register.								
I-Words:	1								
SP Execute Cycles:	1								
DP Execute Cycles:	1								
Repetition Rate:	1								

Note: This instruction only affects the sign bit and will not quit an sNaN input operand.

Example:1	ABS.s	F0, F3	;Find absolute value of a number in F0 and store result in F3			
			Before execution		After execution	
		F0	0x40800001	-1.0000001	F0	0x40800001
		F3	0x00000000		F3	0x40800001
		FSR[7:0]	8'b00000000		FSR[7:0]	8'b00000000

Example:2	ABS.d F0, F2	;Find absolute of a number in F1:F0 and store result in F3:F2				
			Before execution		After execution	
		F1:F0	0x800000000	0000001	F1:F0	0x8000000000000001
		F3:F2	0x000000000	0000000	F3:F2	0x0000000000000001
		FSR[7:0]	8'b00000000		FSR[7:0]	8'b01000000(SUBO) (SUBO)

ADD	Add Fb and Fs
Syntax:	{label:} ADD.s Fb, Fs, Fd ADD.d
Operands (.s):	Fs ∈ [F0 ... F31]; Fb ∈ [F0 ... F31]; Fd ∈ [F0 ... F31]
Operands (.d):	Fs ∈ [F0, F2 ... F30]; Fb ∈ [F0, F2 ... F30]; Fd ∈ [F0, F2 ... F30]
Operation:	Fb + Fs → Fd
Status Affected:	SUBO, INX, UDF, OVF, INVAL (see Note 1)
Exceptions Possible:	SUBO, INX, UDF, OVF, INVAL
Encoding:	1000 000P zzdd ddds ssss www wUUU 0010
Description:	<p>Add the contents of the source register Fb and the contents of the register Fs, then place the result in the destination register Fd. ($\infty + (-\infty)$) will result in distinguished qNaN and signal an INVAL exception.</p> <p>The 'P' bit selects single (.s) or double precision (.d) operation.</p> <p>The 'z' bits select the target coprocessor.</p> <p>The 's' bits select the source register.</p> <p>The 'w' bits select the base register.</p> <p>The 'd' bits select the destination register.</p> <p>Notes:</p> <ol style="list-style-type: none"> If not already set, corresponding sticky exception status will also be set. Coprocessor select bit field zz = 2'b00 for floating-point coprocessor macro.
I-Words:	1
SP Execute Cycles:	2
DP Execute Cycles:	2
Repetition Rate:	1

AND		AND Floating-Point Control/Status Register and Literal						
Syntax:	{label:} AND lit16, FSR FCR FEAR							
Operand	lit16 ∈ [0 ... 65535]							
Operation:	(FP special register[15:0]).AND.lit16 → FP special register[15:0]							
Status Affected:	None (other than as a result of the instruction AND operation)							
Exceptions Possible:	None							
Encoding:	1001 000U z z s s k k k k k k k k k k k k k k 0010							
Description:	<p>Compute the AND of the lsw contents of the selected floating-point coprocessor special register and the literal operand, and write the result back into the lsw of the selected register. The 'z' bits select the target coprocessor.</p> <p>The 's' bits select the floating-point coprocessor source register.</p> <p>The 'k' bits specify the 16-bit literal operand.</p> <p>Notes:</p> <ol style="list-style-type: none"> Coprocessor select bit field zz = 2'b00 for floating-point coprocessor macro. The effect of this instruction is solely to clear bits within the target register. No FPU interrupts can result from its execution. FEAR destination includes the EACE control/status bit. 							
I-Words:	1							
Execute Cycles:	1							
Repetition Rate:	1							

Example:1	AND	#FFF8, FCR	;FCR 0x7 -> To clear INVAL, DIV0 and OVM masks
	Before execution		After execution
	FCR	0x00000300	FCR 0x00000307

COS		Evaluate the Cosine of Fs							
Syntax:	{label:}	COS.s	Fs,	Fd					
Operands (.s):	Fs ∈ [F0 ... F31]; Fd ∈ [F0 ... F31]								
Operation:	cos(Fs) → Fd								
Status Affected:	SUBO, INX, UDF, INVAL (see Note 1)								
Exceptions Possible:	SUBO, INX, UDF, INVAL								
Encoding:	1000	110P	zzdd	ddds	ssss	UUUU	UUUU	0110	
Description:	<p>Calculate the cosine of the contents of the source register Fs (where Fs = [2πk + θ rads]), and place the result in the destination register Fd. The 'z' bits select the target coprocessor.</p> <p>The 's' bits select the source register</p> <p>The 'd' bits select the destination register.</p> <p>Notes:</p> <ol style="list-style-type: none"> If not already set, corresponding sticky exception status will also be set. This operation is only supported using single precision floating-point. Coprocessor select bit field zz = 2'b00 for floating-point coprocessor macro. 								
I-Words:	1								
SP Execute Cycles:	4								
Repetition Rate:	1								

Example:1	COS.s	F0, F3	;Find Cosine of radians in F0 and store result in F3						
			Before execution			After execution			
			F0	0x4016DB6E		F0	0x4016DB6E		
			F3	0x00000000		F3	0xBF3530E2		
			FSR[7:0]	8'b00000000		FSR[7:0]	8'b00000000		

Example:2	COS.s	F0, F3	;Find Cosine of radians in F0 and store result in F3						
			Before execution			After execution			
			F0	0xFF800000		F0	0xFF800000		
			F3	0x00000000		F3	0x7FC00001	(distinguished qNaN)	
			FSR[7:0]	8'b00000000		FSR[7:0]	8'b00000001	(INVAL)	

CPQ Compare Fb with Fs, Quiet Signaling	
Syntax:	{label;} CPQ.s Fb, Fs CPQ.d
Operands (.s):	Fs ∈ [F0 ... F31]; Fb ∈ [F0 ... F31]
Operands (.d):	Fs ∈ [F0, F2 ... F30]; Fb ∈ [F0, F2 ... F30]
Operation:	Fb - Fs (with IEEE signaling predicates)
Status Affected:	LT, GT, EQ, UN, SUBO, INVAL (see Note 1)
Exceptions Possible:	SUBO, INVAL
Encoding:	1000 101P zzUU UUU _s ssss www wUUU 1010
Description:	Compare of the contents of the source registers Fb and Fs (Fb - Fs) then set flags, but do not store the result. An Invalid signaling exception will only be generated if either source operand is a sNaN. A qNaN source operand will not result in a signaling exception. If any source operand is a sNaN or qNaN, then set FSR.UN = 1. The LT, GT and EQ status bits are set depending on the result. The 'P' bit selects single (32-bit) or double precision (64-bit) operation. The 'z' bits select the target coprocessor. The 's' bits select the source register. The 'w' bits select the base register.
	Notes:
	1. If not already set, corresponding sticky exception status will also be set.
	2. Coprocessor select bit field zz = 2'b00 for floating-point coprocessor macro.
	3. This instruction considers -0 and +0 as equivalent.
I-Words:	1
SP Execute Cycles:	1
DP Execute Cycles:	1
Repetition Rate:	1

Example:1	CPQ.s	F0, F3	;(Quiet Signaling)Compare F0 and F3; update FSR[23:16]
		Before execution	After execution
		F0 0xFF7FFFFB	F0 0xFF7FFFFB
		F3 0x80800001	F3 0x80800001
		FSR[23:16] 8'b00000000	FSR[23:16] 8'b00000100 (LT)

Example:2	CPQ.d	F0, F2	;(Quiet Signaling)Compare F1:F0 and F3:F2; update FSR[23:16]
		Before execution	After execution
		F1:F0 0xFFFF80000000 000E	F1:F0 0xFFFF80000000 000E
		F3:F2 0xFFFF80000000 0008	F3:F2 0xFFFF80000000 0008
		FSR[23:16] 8'b00000000	FSR[23:16] 8'b00000001 (UN)
		FSR[7:0] 8'b00000000	FSR[23:16] 8'b00000000

CPS		Compare Fb with Fs, Signaling						
Syntax:	{label:}	CPS.s	Fb,	Fs				
		CPS.d						
Operands (.s):		Fs ∈ [F0 ... F31]; Fb ∈ [F0 ... F31]						
Operands (.d):		Fs ∈ [F0, F2 ... F30]; Fb ∈ [F0, F2 ... F30]						
Operation:		Fb - Fs (with IEEE signaling predicates)						
Status Affected:		LT, GT, EQ, UN, SUBO, INVAL (see Note 1)						
Exceptions Possible:		SUBO, INVAL						
Encoding:		1000	101P	zzUU	UUUs	ssss	www	wUUU 1110
Description:		<p>Compare of the contents of the source registers Fb and Fs (Fb - Fs) then set flags, but do not store the result. If either source operand is a sNaN or a qNaN, an Invalid signaling exception will be generated.</p> <p>If any source operand is a sNaN or qNaN, then set FSR.UN = 1.</p> <p>The LT, GT and EQ status bits are set depending on the result.</p> <p>The 'P' bit selects single (32-bit) or double precision (64-bit) operation.</p> <p>The 'z' bits select the target coprocessor.</p> <p>The 's' bits select the source register.</p> <p>The 'w' bits select the base register.</p> <p>Notes:</p> <ol style="list-style-type: none"> If not already set, corresponding sticky exception status will also be set. Coprocessor select bit field zz = 2'b00 for floating-point coprocessor macro. This instruction consider -0 and +0 as equivalent. 						
I-Words:		1						
SP Execute Cycles:		1						
DP Execute Cycles:		1						
Repetition Rate:		1						

Example:1 CPS.s F0, F3 ;(Signaling)Compare F0 and F3
; update FSR[23:16]

Before execution		After execution			
F0	0xFF7FFFFB	F0	0xFF7FFFFB		
F3	0x80800001	F3	0x80800001		
FSR[23:16]	8'b00000000	FSR[23:16]	8'b00000100	(LT)	

Example:2 CPS.d F0, F2 ;(Signaling)Compare F1:F0 and F3:F2
; update FSR[23:16]

Before execution		After execution			
F1:F0	0xFFF800000000000E	F1:F0	0xFFF800000000000E		
F3:F2	0xFFF8000000000008	F3:F2	0xFFF8000000000008		
FSR[23:16]	8'b00000000	FSR[23:16]	8'b00000001	(UN)	
FSR[7:0]	8'b00000000	FSR[23:16]	8'b00000001	(INVAL)	

DI2F Convert Double Word (64-bit) Integer to Floating Point

Syntax:	{label:} DI2F.s{rnd} Fs, Fd DI2F.d{rnd}
Operands (.s):	Fs ∈ [F0, F2 ... F30]; Fd ∈ [F0 ... F31]; rnd ∈ [e, z, p, n]
Operands (.d):	Fs ∈ [F0, F2 ... F30]; Fd ∈ [F0, F2 ... F30]; rnd ∈ [e, z, p, n]
Operation:	Fs (integer) → Fd (float)
Status Affected:	INX ¹
Exceptions Possible:	INX
Encoding:	1000 111P zzdd ddds ssss UUUU Ueee 1110
Description:	<p>Convert the 64-bit integer contents of the source register Fs to floating point, round, then place the result in the destination register Fd. If rounding mode {rnd} is not specified, it will default to that defined by FCR.RND[1:0]. If the integer cannot be represented exactly as a floating point value, the Inexact signaling exception will be generated.</p> <p>The 'P' bit selects single (.s) or double precision (.d) operation.</p> <p>The 'e' bits define the rounding mode applied.</p> <p>The 'z' bits select the target coprocessor.</p> <p>The 's' bits select the source register.</p> <p>The 'd' bits select the destination register.</p> <p>Notes:</p> <ol style="list-style-type: none"> 1. If not already set, corresponding sticky exception status will also be set. 2. Coprocessor select bit field zz = 2'b00 for floating-point coprocessor macro.
I-Words:	1
SP Execute Cycles:	2
DP Execute Cycles:	2
Repetition Rate:	1

Example:1 DI2F.sp F0, F2 ;Convert 64-bit double long-word integer to a SP floating-point value (with rounding = pos)

Before execution		After execution	
F1:F0	0x7FFFFFFFFFFF FFFB	F1:F0	0x7FFFFFFFFFFF FFFB
F2	0x00000000	F2	0x5EFFFFFF
FSR[7:0]	8'b00000000	FSR[7:0]	8'b00010000 (INX)

Example:2 DI2F.dz F0, F2 ;Convert 64-bit double long-word integer to a DP floating-point value (with rounding = zero)

Before execution		After execution	
F1:F0	0xFFFFFFFFFFFFFFFF	F1:F0	0xFFFFFFFFFFFFFFFF
F3:F2	0x0000000000000000	F3:F2	0xBFF0000000000000

DIV Signed Floating-Point Divide	
Syntax:	{label:} DIV.s Fb Fs, Fd DIV.d
Operands (.s):	Fs ∈ [F0 ... F31]; Fb ∈ [F0 ... F31]; Fd ∈ [F0 ... F31]
Operands (.d):	Fs ∈ [F0, F2 ... F30]; Fb ∈ [F0, F2 ... F30]; Fd ∈ [F0, F2 ... F30]
Operation:	$Fb \div F_s \rightarrow F_d$
Status Affected:	SUBO, INX, UDF, OVF, DIV0, INVAL (see Note 1)
Exceptions Possible:	SUBO, INX, UDF, OVF, DIV0, INVAL
Encoding:	1000 010P zzdd ddds ssss www wUUU 1010
Description:	<p>Divide the contents of the source register Fb with the contents of the source register Fs, then place the result in the destination register Fd.</p> <p>Result of ($\infty/0$) is correctly signed infinity. Whereas, ((0/0) or (∞/∞)) will result in distinguished qNaN and signal an FPU INVAL exception.</p> <p>The 'P' bit selects single (.s) or double precision (.d) operation.</p> <p>The 'z' bits select the target coprocessor.</p> <p>The 's' bits select the source register.</p> <p>The 'w' bits select the base register.</p> <p>The 'd' bits select the destination register.</p> <p>Notes:</p> <ol style="list-style-type: none"> 1. If not already set, corresponding sticky exception status will also be set. 2. An attempt to divide by zero may or may not signal DIV0 depending upon operands. 3. Coprocessor select bit field zz = 2'b00 for floating-point coprocessor macro.
I-Words:	1
SP Execute Cycles:	11
DP Execute Cycles:	32

Example:1	DIV.s F0, F1, F3	;Divide the contents in F0 by F1 and store the result in F3
	Before execution	After execution
	F0 0x7F00000A	F0 0x7F00000A
	F1 0xFF0000AA	F1 0xFF0000AA
	F3 0x00000000	F3 0xBF7FFEC0
	FSR[7:0] 8'b00000000	FSR[7:0] 8'b00000000

Example:2	DIV.d F0, F4, F8	;Divide the contents in F1:F0 by F5:F4 and store the results in F9:F8
	Before execution	After execution
	F1:F0 0xFFEA36E2EB1C432D	F1:F0 0xFFEA36E2EB1C432D
	F5:F4 0x0000000000A00000	F5:F4 0x0000000000A00000
	F9:F8 0x0000000000000000	F9:F8 0xFFEFFFFFFFFFFFFF
	FSR[7:0] 8'b00000000	FSR[7:0] 8'b01010100 (INX, OVF, SUBO)

FLIM		Force Signed Data Limit						
Syntax:	{label:}	FLIM.s	Fb,	Fs,	Fd			
		FLIM.d						
Operands (.s):		Fs ∈ [F0 ... F31]; Fb ∈ [F0 ... F31]; Fd ∈ [F0 ... F31]						
Operands (.d):		Fs ∈ [F0, F2 ... F30]; Fb ∈ [F0, F2 ... F30]; Fd ∈ [F0, F2 ... F30]						
Operation:		IF (Fd) > (Fs) THEN (Fs) → (Fd); IF (Fd) < (Fb) THEN (Fb) → (Fd);						
Status Affected:		SUBO, INVAL (see Note 1)						
Exceptions Possible:		SUBO, INVAL						
Encoding:		1001	001P	zzdd	ddds	ssss	www	wUUU 0010
Description:		<p>Simultaneously compare a signed floating-point value in Fd to a maximum signed floating-point value held in Fs and a minimum signed floating-point value held in Fb. If Fd is greater than Fs, set Fd to the limit value held in Fs. If Fd is less than Fb, set Fd to the limit value held in Fb. If Fd is less than or equal to the maximum limit value in Fs, and greater than or equal to the minimum limit value in Fb, Fd is not modified (i.e., data is within range and limits are not applied). See note 2. If any of the operands (limit values or value to be tested) are an sNaN or a qNaN, the instruction will return a qNaN as the result. In addition, if any of the operands are an sNaN, the INVAL status will be set. Should the (maximum) limit value Fs be inadvertently set to less than (minimum) limit value Fb, the instruction will return the distinguished qNaN as the result and set the INVAL status. This is a signed comparison operation. The limits may both be of the same sign. The 'P' bit selects single (32-bit) or double precision (64-bit) operation. The 'z' bits select the target coprocessor. The 's' bits select the source register. The 'w' bits select the base register. The 'd' bits select the destination register. If not already set, corresponding sticky exception status will also be set. Coprorocessor select bit field zz = 2'b00 for floating-point coprocessor macro.</p>						
I-Words:		1						
SP Execute Cycles:		1						
DP Execute Cycles:		1						
Repetition Rate:		1						

Example:1 FLIM.s F3, F0, F1 ;Limit the value in F3 to be within values in F0 and F1

	Before execution	After execution
F0	0xFF669595	0xFF000000
F1	0xFF000000	0xFF000000
F3	0x44480000	0x44480000

Example:2 FLIM.d F6, F4, F0 ;Limit the value in F7:F6 to be within values in F5:F4 and F1:F0

	Before execution	After execution
F1:F0	0xC024000000000000	0xC014000000000000
F5:F4	0x4024000000000000	0x4024000000000000
F9:F8	0xC014000000000000	0xC014000000000000

F2DI Convert Floating-Point Fs to Double Word (64-bit) Integer

Syntax:	{label:} F2DI.s{rnd} Fs, Fd F2DI.d{rnd}
Operands (.s):	Fs ∈ [F0 ... F31]; Fd ∈ [F0, F2 ... F30]; rnd ∈ [e, z, p, n]
Operands (.d):	Fs ∈ [F0, F2 ... F30]; Fd ∈ [F0, F2 ... F30]; rnd ∈ [e, z, p, n]
Operation:	Fs (float) → Fd (integer)
Status Affected:	SUBO, HUGI, INX, INVAL (see Note 1)
Exceptions Possible:	SUBO, HUGI, INX, INVAL
Encoding:	1000 111P zzdd ddds ssss UUUU Ueee 0110
Description:	<p>Convert the floating-point contents of the source register Fs to a rounded 64-bit integer, then place the result in the destination register Fd. If rounding mode {rnd} is not specified, it will default to that defined by FCR.RND[1:0].</p> <p>If the source register contains ±NaN or ±∞, the INVAL exception will be signaled and the result will be the integer indefinite value of 0x8000_0000_0000_0000 (maximum negative integer).</p> <p>If the source register contains a finite floating point number, but the result rounds to a number greater than 2⁶³-1 or less than -2⁶³, the HUGI and INVAL exceptions will be signaled and the default result will be the integer indefinite value of 0x7FFF_FFFF_FFFF_FFFF or 0x8000_0000_0000_0000, respectively.</p> <p>If the source register contains a subnormal value, the result will always be zero and the INX exception will be signaled.</p> <p>The 'P' bit selects single (.s) or double precision (.d) operation.</p> <p>The 'e' bits define the rounding mode applied.</p> <p>The 'z' bits select the target coprocessor.</p> <p>The 's' bits select the source register.</p> <p>The 'd' bits select the destination register.</p> <p>Notes:</p> <ol style="list-style-type: none"> If not already set, corresponding sticky exception status will also be set. Coprocessor select bit field zz = 2'b00 for floating-point coprocessor macro.
I-Words:	1
SP Execute Cycles:	1 (subject to change)
DP Execute Cycles:	2 (subject to change)
Repetition Rate:	1

Example:1 F2DI.sp F0, F2 ;Convert SP float value to a 64-bit double long-word integer(with rounding = pos)

	Before execution		After execution
F0	0xD7FFFFFFE	F0	0xD7FFFFFFE
F3:F2	0x0000000000000000	F3:F2	0xFFFE00004000000
FSR[7:0]	8'b00000000	FSR[7:0]	8'b00010000 (INX)

Example:2 F2DI.dz F0, F2 ;Convert DP float value to a 64-bit double long-word integer(with rounding = zero)

	Before execution		After execution
F1:F0	0xC2E4F8B5877 B8000	F1:F0	0xC2E4F8B5877 B8000
F3:F2	0x000000000000 00000	F3:F2	0xFFFF583A53C 42400

F2LI Convert Floating-Point Fs to Long Word (32-bit) Integer	
Syntax:	{label:} F2LI.s{rnd} Fs, Fd F2LI.d{rnd}
Operands (.s):	Fs ∈ [F0 ... F31]; Fd ∈ [F0 ... F31]; rnd ∈ [e, z, p, n]
Operands (.d):	Fs ∈ [F0, F2 ... F30]; Fd ∈ [F0 ... F31]; rnd ∈ [e, z, p, n]
Operation:	Fs (float) → Fd (integer)
Status Affected:	SUBO, HUGI, INX, INVAL (see Note 1)
Exceptions Possible:	SUBO, HUGI, INX, INVAL
Encoding:	1000 111P zzdd ddds ssss UUUU Ueee 0010
Description:	<p>Convert the floating-point contents of the source register Fs to a rounded 32-bit integer, then place the result in the destination register Fd. If rounding mode {rnd} is not specified, it will default to that defined by FCR.RND[1:0].</p> <p>If the source register contains ±NaN or ±∞, the INVAL exception will be signaled and the result will be the integer indefinite value of 0x8000_0000 (maximum negative integer).</p> <p>If the source register contains a finite floating-point number but the result rounds to a number greater than 2³¹-1 or less than -2³¹, the HUGI and INVAL exceptions will be signaled and the default result will be the integer indefinite value of 0x7FFF_FFFF or 0x8000_0000, respectively.</p> <p>If the source register contains a subnormal value, the result will always be zero and the INX exception will be signaled.</p> <p>The 'P' bit selects single (.s) or double precision (.d) operation.</p> <p>The 'e' bits define the rounding mode applied.</p> <p>The 'z' bits select the target coprocessor.</p> <p>The 's' bits select the source register.</p> <p>The 'd' bits select the destination register.</p> <p>Notes:</p> <ol style="list-style-type: none"> If not already set, corresponding sticky exception status will also be set. Coprocessor select bit field zz = 2'b00 for floating-point coprocessor macro.
I-Words:	1
SP Execute Cycles:	1
DP Execute Cycles:	2
Repetition Rate:	1

Example:1 F2LI.sp F0, F1 ;Convert SP float value to a long-word integer(with rounding = pos)

Before execution	After execution
F0 0xCA0EF725	F0 0xCA0EF725
F1 0x00000000	F1 0xFFDC4237
FSR[7:0] 8'b00000000	FSR[7:0] 8'b00010000 (INX)

Example:2 F2LI.dz F0, F2 ;Convert DP float value to a long-word integer(with rounding = zero)

Before execution	After execution
F1:F0 0xC09F40000000 00000	F1:F0 0xC09F400000000000
F2 0x00000000	F2 0xFFFFF830

FBRA CC	FPU Coprocessor Branch
Syntax:	{label:} FBRA CC, Expr
Operands:	Expr is resolved by the linker to a signed word offset (slit20)
Operation:	Condition (cc) = See Table x.y If (cc) then { If slit20 = 1 then skip next (16-bit) instruction Else if (slit20 = 2 && next_op[31] = 1) then skip next (32-bit) instruction Else (PC+4) + 2*slit20 → PC } Else no branch
Status Affected:	None
Encoding:	1011 bbbb nnnn nnnn nnnn nnnn nnnn zz10 See Table 4-13 for the value of “bbbb”

Table 4-13. FBRA Conditions (continued)

FBRA CC	FPU Coprocessor Branch
Description:	<p>If the branch condition is met, then the instruction will either skip the next 16-bit or 32-bit instruction, or it will branch to any size of instruction with a forward or backward range of 1MB.</p> <p>If the 2's complement byte offset value '2*slit20' (the PC offset) equals two, the conditional branch will execute as a conditional skip of one 16-bit instruction. This instruction will be speculatively executed as not skipped until such time that the branch decision can be determined.</p> <p>If the 2's complement byte offset value '2*slit20' (the PC offset) equals four and the instruction after the branch is a 32-bit opcode (see note), the conditional branch will execute as a conditional skip of that 32-bit instruction. This instruction will be speculatively executed as not skipped until such time that the branch decision can be determined.</p> <p>If requirements for a conditional skip are not met, the 2's complement byte offset value '2*slit20' is added to the PC to create a new PS word address. Since the PC will have incremented to fetch the next instruction, the new address will be $(PC+4) + 2*slit20$.</p> <p>Branch prediction is based on the direction of the branch. If the branch is backwards (negative), it will be predicted as taken. If the branch is forwards (positive), it will be predicted as not taken.</p> <p>The two instructions that follow the branch will then be speculatively executed in the predicted path until such time that the actual branch decision can be assessed. A correctly predicted branch will continue instruction execution in the same path unabated. An incorrectly predicted branch will abort the speculatively executed instructions and start execution from the correct path.</p> <p>The 'n' bits are a signed literal that specifies the number of PS words offset from (PC+4). The 'z' bits select the target coprocessor.</p> <p>FPU co-processor supports number of branch conditions (cc) as mentioned in following table.</p>

Table 4-13. FBRA Conditions

cc	Conditions	Encoding (bbbb)
EQ	FSR.EQ	0000
UNE	(FSR.GT FSR.LT FSR.UN)	0001
NE	(FSR.GT FSR.LT)	0010
UEQ	(FSR.EQ FSR.UN)	0011
GT	FSR.GT	0100
ULE	(FSR.LT FSR.EQ FSR.UN)	0101
GE	(FSR.GT FSR.EQ)	0110
ULT	(FSR.LT FSR.UN)	0111
LT	FSR.LT	1000
UGE	(FSR.GT FSR.EQ FSR.UN)	1001
LE	(FSR.LT FSR.EQ)	1010
UGT	(FSR.GT FSR.UN)	1011
OR	(FSR.GT FSR.LT FSR.EQ)	1100
UN	FSR.UN	1101

Notes:

1. Coprocessor select bit field zz = 2'b00 for floating-point coprocessor macro.
2. Should the byte offset equal four and instruction after the branch is a 16-bit opcode, a branch will occur (over the next two 16-bit ops) if the condition is met.
3. Branch conditions are evaluated within the coprocessor.

I-Words:

1

Cycles:

1 (2 or 3)

IOR		Inclusive OR Floating-Point Control/Status Register and Literal						
Syntax:	{label:}	IOR	lit16,	FSR				
				FCR				
				FEAR				
Operand		lit16 ∈ [0 ... 65535]						
Operation:		(FP special register[15:0]).IOR.lit16 → FP special register[15:0]						
Status Affected:		None (other than as a result of the instruction OR operation)						
Exceptions Possible:		None						
Encoding:		1001	000U	zzss	kkkk	kkkk	kkkk	kkkk 0110
Description:		<p>Compute the inclusive OR of the contents of the lsw of the selected floating-point coprocessor register and the literal operand, and write the result back into the lsw of the selected register. The 'z' bits select the target coprocessor.</p> <p>The 's' bits select the floating-point coprocessor source register.</p> <p>The 'k' bits specify the 16-bit literal operand.</p> <p>Notes:</p> <ol style="list-style-type: none"> Coprocessor select bit field zz = 2'b00 for floating-point coprocessor macro. The effect of this instruction is solely to set bits within the target register. No FPU interrupts can result from its execution. FEAR destination includes the EACE control/status bit. 						
I-Words:		1						
Execute Cycles:		1						
Repetition Rate:		1						

Example:1	IOR #7, FCR	;FCR 0x7 -> To set INVALID, DIV0 and OVM masks			
		Before execution		After execution	
		FCR	0x00000300	FCR	0x00000307

LI2F		Convert Long Word (32-bit) Integer to Floating-Point							
Syntax:	{label:}	LI2F.s{rnd}	Fs,	Fd					
		LI2F.d{rnd}							
Operands (.s):		Fs ∈ [F0 ... F31]; Fd ∈ [F0 ... F31]; rnd ∈ [e, z, p, n]							
Operands (.d):		Fs ∈ [F0 ... F31]; Fd ∈ [F0, F2 ... F30]; rnd ∈ [e, z, p, n] ³							
Operation:		Fs (integer) → Fd (float)							
Status Affected:		INX ^{1,3}							
Exceptions Possible:		INX							
Encoding:		1000	111P	zzdd	ddds	ssss	UUUU	Ueee	1010
Description:		<p>Convert the 32-bit integer contents of the source register Fs to floating-point, round, and then place the result in the destination register Fd. If rounding mode {rnd} is not specified, it will default to that defined by FCR.RND[1:0]. If the integer cannot be represented exactly as a floating-point value, the Inexact signaling exception will be generated (see note 3). The 'P' bit selects single (.s) or double precision (.d) operation.</p> <p>The 'e' bits define the rounding mode applied.</p> <p>The 'z' bits select the target coprocessor.</p> <p>The 's' bits select the source register.</p> <p>The 'd' bits select the destination register.</p> <p>Notes:</p> <ol style="list-style-type: none"> 1. If not already set, corresponding sticky exception status will also be set. 2. Coprocessor select bit field zz = 2'b00 for floating-point coprocessor macro. 3. Long integer to Double Precision float (LI2F.d) conversion are always exact, so Inexact (INX) status will never be set. Similarly, rounding modes will have no effect on LI2F.d result. 							
I-Words:		1							
SP Execute Cycles:		1							
DP Execute Cycles:		1							
Repetition Rate:		1							

Example:1 LI2F.se F0, F1 ;Convert long-word integer to SP float value (with even rounding)

Before execution		After execution	
F0	0xFFFFF830	F0	0xFFFFF830
F1	0x00000000	F1	0xC4FA0000

Example:2 LI2F.d F0, F2 ;Convert long-word integer to DP float value

Before execution		After execution	
F0	0xAFF0BDBC	F0	0xAFF0BDBC
F3:F2	0x0000000000000000	F3:F2	0xC1D403D091000000

MAC		Floating-Point Signed Multiply and Accumulate							
Syntax:	{label:}	MAC.s	Fb,	Fs,	Fd				
		MAC.d							
Operands (.s):		Fs ∈ [F0 ... F31]; Fb ∈ [F0 ... F31]; Fd ∈ [F0 ... F31]							
Operands (.d):		Fs ∈ [F0, F2 ... F30]; Fb ∈ [F0, F2 ... F30]; Fd ∈ [F0, F2 ... F30]							
Operation:		(Fd) + ((Fb) * (Fs)) → Fd;							
Status Affected:		SUBO, INX, UDF, OVF, INVAL (see Note 1)							
Exceptions Possible:		SUBO, INX, UDF, OVF, INVAL							
Encoding:		1000	010P	zzdd	ddds	ssss	www	wUUU	0010
Description:		Multiply the signed contents of the source register Fb with the signed contents of the source register Fs, then add the product to Fd. The 'P' bit selects single (.s) or double precision (.d) operation. The 'z' bits select the target coprocessor. The 's' bits select the source register. The 'w' bits select the base register. The 'd' bits select the destination register.							
		Notes:							
		1. If not already set, corresponding sticky exception status will also be set. 2. Coprocessor select bit field zz = 2'b00 for floating-point coprocessor macro.							
I-Words:		1							
SP Execute Cycles:		3							
DP Execute Cycles:		4							
Repetition Rate:		1							

Example:1 MAC.s F3, F0, F1 ;Multiply contents of F0, F1 and add the results with content in F3

Before execution		After execution	
F0	0x80FFFFFF	F0	0x80FFFFFF
F1	0x00000000	F1	0x00000000
F3	0x80FFFFFFE	F3	0x00000000
FSR[7:0]	8'b00000000	FSR[7:0]	8'b00011000 (UDF, INX)

Example:2 MAC.d F6, F4, F0 ;Multiply contents of F1:F0, F5:F4 and add the results with content in F7:F6

Before execution		After execution	
F1:F0	0x4069000000000000	F1:F0	0x4069000000000000
F5:F4	0x407F400000000000	F5:F4	0x407F400000000000
F9:F8	0x4024000000000000	F9:F8	0x40A3880000000000
FSR[7:0]	8'b00000000	FSR[7:0]	8'b00000000

MAX **Select the Signed Maximum of Fb and Fs**
{IEEE 754-2019 maximum(x,y)}

Syntax:	{label:} MAX.s Fb, Fs, Fd MAX.d
Operands (.s):	Fs ∈ [F0 ... F31]; Fb ∈ [F0 ... F31]; Fd ∈ [F0 ... F31]
Operands (.d):	Fs ∈ [F0, F2 ... F30]; Fb ∈ [F0, F2 ... F30]; Fd ∈ [F0, F2 ... F30]
Operation:	IF (Fs) >= (Fb) THEN (Fs) → (Fd); ELSE (Fb) → (Fd)
Status Affected:	SUBO, INVAL (see Note 1)
Exceptions Possible:	SUBO, INVAL
Encoding:	1000 001P zzdd ddds ssss wwww wUUU 0010
Description:	<p>Find the signed maximum of two floating-point values held in Fb and Fs. This instruction is compliant with the IEEE 754-2019 maximum() operation.</p> <p>Compare the contents of the source registers Fb and Fs, then place the maximum of the two values in the destination register Fd. This is a signed comparison operation (see note 3). If Fb = Fs (and of the same sign), Fd is loaded with the contents of Fs.</p> <p>When one (or both) of the input operands is a NaN, the instructions will return a qNaN.</p> <p>The 'P' bit selects single (32-bit) or double precision (64-bit) operation.</p> <p>The 'z' bits select the target coprocessor.</p> <p>The 's' bits select the source register.</p> <p>The 'w' bits select the base register.</p> <p>The 'd' bits select the destination register.</p> <p>Notes:</p> <ol style="list-style-type: none"> 1. If not already set, corresponding sticky exception status will also be set. 2. Coprocessor select bit field zz = 2'b00 for floating-point coprocessor macro. 3. Operand value of -0 compares to less than +0.
I-Words:	1
SP Execute Cycles:	1
DP Execute Cycles:	1
Repetition Rate:	1

Example:1 MAX.s F0, F1, F3 ;Returns maximum of F0, F1 to F3 (Follows IEEE 754-2019 maximum())

Before execution		After execution	
F0	0x7F800000	F0	0x7F800000
F1	0xFF800000	F1	0xFF800000
F3	0x00000000	F3	0x7F800000
FSR[7:0]	8'b00000000	FSR[7:0]	8'b00000000

Example:2 MAX.d F0, F4, F8 ;Returns maximum of F1:F0, F5:F4 to F9:F8 (Follows IEEE 754-2019 maximum())

Before execution		After execution	
F1:F0	0x000000000000 0000A	F1:F0	0x000000000000 0000A
F5:F4	0xC00000000000 0000C	F5:F4	0xC00000000000 0000C
F9:F8	0x000000000000 000	F9:F8	0x000000000000 0000A
FSR[7:0]	8'b00000000	FSR[7:0]	8'b01000000 (SUBO)

MAXNM **Select the Signed Maximum of Fb and Fs**
{IEEE 754-2019 maximumNumber(x,y)}

Syntax:	{label:} MAXNM.s Fb, Fs, Fd MAXNM.d
Operands (.s):	Fs ∈ [F0 ... F31]; Fb ∈ [F0 ... F31]; Fd ∈ [F0 ... F31]
Operands (.d):	Fs ∈ [F0, F2 ... F30]; Fb ∈ [F0, F2 ... F30]; Fd ∈ [F0, F2 ... F30]
Operation:	IF (Fs) >= (Fb) THEN (Fs) → (Fd); ELSE (Fb) → (Fd)
Status Affected:	SUBO, INVAL (see Note 1)
Exceptions Possible:	SUBO, INVAL
Encoding:	1000 001P zzdd ddds ssss www wUUU 0110
Description:	<p>Find the signed maximum of two floating-point values held in Fb and Fs. This instruction is compliant with the IEEE 754-2019 maximumNumber() operation.</p> <p>Compare the contents of the source registers Fb and Fs, then place the maximum of the two values in the destination register Fd. If Fb = Fs, Fd is loaded with the contents of Fs. This is a signed comparison operation (see note 3). If Fb = Fs (and of the same sign), Fd is loaded with the contents of Fs.</p> <p>When one of the input operands is a NaN and the other input is a floating-point number (that is not a NaN), the instructions will return the floating-point number.</p> <p>If both input operands are a NaN, the instructions will return a qNaN.</p> <p>The 'P' bit selects single (32-bit) or double precision (64-bit) operation.</p> <p>The 'z' bits select the target coprocessor.</p> <p>The 's' bits select the source register.</p> <p>The 'w' bits select the base register.</p> <p>The 'd' bits select the destination register.</p> <p>Notes:</p> <ol style="list-style-type: none"> 1. If not already set, corresponding sticky exception status will also be set. 2. Coprocessor select bit field zz = 2'b00 for floating-point coprocessor macro. 3. Operand value of -0 compares to less than +0.
I-Words:	1
SP Execute Cycles:	1
DP Execute Cycles:	1
Repetition Rate:	1

Example:1 MAXNM.s F0, F1, F3 ;Returns maximum of F0, F1 to F3

Before execution		After execution	
F0	0x00000000	F0	0x00000000
F1	0x80000000	F1	0x80000000
F3	0x00000000	F3	0x00000000
FSR[7:0]	8'b00000000	FSR[7:0]	8'b00000000

Example:2 MAXNM.d F0, F4, F8 ;Returns maximum of F1:F0, F5:F4 to F9:F8

Before execution		After execution	
F1:F0	0x800000000000000A	F1:F0	0x800000000000000A
F5:F4	0x3FF924920048245C	F5:F4	0x3FF924920048245C
F9:F8	0x0000000000000000	F9:F8	0x3FF924920048245C
FSR[7:0]	8'b00000000	FSR[7:0]	8'b01000000 (SUBO)

MIN **Select the Signed Minimum of Fb and Fs**
{IEEE 754-2019 minimum(x,y)}

Syntax:	{label:} MIN.s Fb, Fs, Fd MIN.d
Operands (.s):	Fs ∈ [F0 ... F31]; Fb ∈ [F0 ... F31]; Fd ∈ [F0 ... F31]
Operands (.d):	Fs ∈ [F0, F2 ... F30]; Fb ∈ [F0, F2 ... F30]; Fd ∈ [F0, F2 ... F30]
Operation:	IF (Fs) <= (Fb) THEN (Fs) → (Fd); ELSE (Fb) → (Fd)
Status Affected:	SUBO, INVAL (see note 1)
Exceptions Possible:	SUBO, INVAL
Encoding:	1000 001P zzdd ddds ssss wwww wUUU 1010
Description:	<p>Find the signed minimum of two floating-point values held in Fb and Fs. This instruction is compliant with the IEEE 754-2019 minimum() operation.</p> <p>Compare the contents of the source registers Fb and Fs, then place the minimum of the two values in the destination register Fd. This is a signed comparison operation (see note 3). If Fb = Fs (and of the same sign), Fd is loaded with the contents of Fs.</p> <p>When one (or both) of the input operands is a NaN, the instructions will return a qNaN.</p> <p>The 'P' bit selects single (32-bit) or double precision (64-bit) operation.</p> <p>The 'z' bits select the target coprocessor.</p> <p>The 's' bits select the source register.</p> <p>The 'w' bits select the base register.</p> <p>The 'd' bits select the destination register.</p> <p>Notes:</p> <ol style="list-style-type: none"> 1. If not already set, corresponding sticky exception status will also be set. 2. Coprocessor select bit field zz = 2'b00 for floating-point coprocessor macro. 3. Operand value of -0 compares to less than +0.
I-Words:	1
SP Execute Cycles:	1
DP Execute Cycles:	1
Repetition Rate:	1

Example:1 MIN.s F0, F1, F3 ;Returns minimum of F0, F1 to F3 (Follows IEEE 754-2019 minimum())

Before execution	After execution
F0 0x7F800000	F0 0x7F800000
F1 0xFF800000	F1 0xFF800000
F3 0x00000000	F3 0xFF800000
FSR[7:0] 8'b00000000	FSR[7:0] 8'b00000000

Example:2 MIN.d F0, F4, F8 ;Returns minimum of F1:F0, F5:F4 to F9:F8 (Follows IEEE 754-2019 minimum())

Before execution	After execution
F1:F0 0x000000000000 0000A	F1:F0 0x000000000000 0000A
F5:F4 0xC00000000000 0000C	F5:F4 0xC00000000000 0000C
F9:F8 0x000000000000 000	F9:F8 0xC00000000000 0000C
FSR[7:0] 8'b00000000	FSR[7:0] 8'b01000000 (SUBO)

MINNM Select the Signed Minimum of Fb and Fs [minimumNumber()]

Syntax:	{label:} MINNM.s Fb, Fs, Fd MINNM.d
Operands (.s):	Fs ∈ [F0 ... F31]; Fb ∈ [F0 ... F31]; Fd ∈ [F0 ... F31]
Operands (.d):	Fs ∈ [F0, F2 ... F30]; Fb ∈ [F0, F2 ... F30]; Fd ∈ [F0, F2 ... F30]
Operation:	IF (Fs) <= (Fb) THEN (Fs) → (Fd); ELSE THEN (Fb) → (Fd)
Status Affected:	SUBO, INVAL (see Note 1)
Exceptions Possible:	SUBO, INVAL
Encoding:	1000 001P zzdd ddds ssss www wUUU 1110
Description:	<p>Find the signed minimum of two floating-point values held in Fb and Fs. This instruction is compliant with the IEEE 754-2019 minimumNumber() operation.</p> <p>Compare the contents of the source registers Fb and Fs, then place the minimum of the two values in the destination register Fd. If Fb = Fs, Fd is loaded with the contents of Fs. This is a signed comparison operation (see note 3). If Fb = Fs (and of the same sign), Fd is loaded with the contents of Fs.</p> <p>When one of the input operands is a NaN and the other input is a floating-point number (that is not a NaN), the instructions will return the floating-point number.</p> <p>If both input operands are a NaN, the instructions will return a qNaN.</p> <p>The 'P' bit selects single (32-bit) or double precision (64-bit) operation.</p> <p>The 'z' bits select the target coprocessor.</p> <p>The 's' bits select the source register.</p> <p>The 'w' bits select the base register.</p> <p>The 'd' bits select the destination register.</p> <p>Notes:</p> <ol style="list-style-type: none"> 1. If not already set, the corresponding sticky exception status will also be set. 2. Coprocessor select bit field zz = 2'b00 for floating-point coprocessor macro. 3. Operand value of -0 compares to less than +0.
I-Words:	1
SP Execute Cycles:	1
DP Execute Cycles:	1
Repetition Rate:	1

Example:1 MINNM.s F0, F1, F3 ;Returns minimum of F0, F1 to F3

	Before execution		After execution
	F0 0x00000000		F0 0x00000000
	F1 0x80000000		F1 0x80000000
	F3 0x00000000		F3 0x80000000
	FSR[7:0] 8'b00000000		FSR[7:0] 8'b00000000

Example:2 MINNM.d F0, F4, F8 ;Returns minimum of F1:F0, F5:F4 to F9:F8

	Before execution		After execution
F1:F0	0x800000000000 0000A	F1:F0	0x800000000000 0000A
F5:F4	0x3FF924920048 245C	F5:F4	0x3FF924920048 245C
F9:F8	0x000000000000 000	F9:F8	0x800000000000 0000A
FSR[7:0]	8'b00000000	FSR[7:0]	8'b01000000 (SUBO)

MOV		Move Coprocessor Register to Wns with Signed Literal Offset						
Syntax:	{label;} MOV.l Fs, [Wnd+Slit14]							
Operands:	Wnd ∈ [W0 ... W15] Fs ∈ [F0 ... F31]							
Operation:	Wns → [Wnd+Slit14]							
Status Affected:	None							
Encoding:	1000 011s ssss dddd kkkk kkkk kkkk zz01							
Description:	<p>Moves contents of the destination register to the source Effective Address. Syntax shown is for the floating-point coprocessor F-regs. The contents of Wnd are not modified by this operation. The instruction encoding includes space for a 12-bit literal which is scaled accordingly for long word data moves in order to generate the corresponding byte offset value.</p> <p>The 'z' bits select the target coprocessor.</p> <p>The 's' bits select the source register.</p> <p>The 'd' bits select the floating-point destination register.</p> <p>Note:</p> <ol style="list-style-type: none"> This instruction operates in Long Word mode only. 							
I-Words:	1							
Cycles:	1							

MOV		Move Fs to Fd	
Syntax:	{label:}	MOV.s	Fs, Fd MOV.d
Operands (.s):	Fs ∈ [F0 ... F31]; Fd ∈ [F0 ... F31]		
Operands (.d):	Fs ∈ [F0, F2 ... F30]; Fd ∈ [F0, F2 ... F30]		
Operation:	Fs → Fd		
Status Affected:	None		
Exceptions Possible:	None		
Encoding:	1000	011P	zzdd ddds ssss UUUU UUUU 0010
Description:	<p>Move (copy) the contents of the source register Fs to the destination register Fd. The 'P' bit selects single (.s) or double precision (.d) operation.</p> <p>The 'z' bits select the target coprocessor.</p> <p>The 's' bits select the source register.</p> <p>The 'd' bits select the destination register.</p> <p>Note: Coprocessor select bit field zz = 2'b00 for floating-point coprocessor macro.</p>		
I-Words:	1		
SP Execute Cycles:	1		
DP Execute Cycles:	1		
Repetition Rate:	1		

Example:1	MOV.s F0, F1	;Move single precision content of F0 to F1
-----------	--------------	--

Before execution		After execution	
F0	0x40C90FDB	F0	0x40C90FDB
F1	0x00000000	F1	0x40C90FDB

Example:2	MOV.d F0, F2	;Move double precision content of F1:F0 to F3:F2
-----------	--------------	--

Before execution		After execution	
F1:F0	0x3FE62E42FEFA 39EF	F1:F0	0x3FE62E42FEFA 39EF
F3:F2	0x000000000000 00000	F3:F2	0x3FE62E42FEFA 39EF

MOVC		Move Constant Value to Fd			
Syntax:	{label:} MOVC.s index, Fd MOVC.d				
Operands (.s):	Fd ∈ [F0 ... F31]; index ∈ [0 ... 31]				
Operands (.d):	Fd ∈ [F0, F2 ... F30]; index ∈ [0 ... 31]				
Operation:	Constant table (index) → Fd				
Status Affected:	None				
Exceptions Possible:	None				
Encoding:	1000 011P zzdd dddU UUUU UUUk kkkk 0110				
Description:	<p>Move the constant value specified by the 5-bit index into the Fd register, as defined in the tables below.</p> <p>The 'P' bit selects single (.s) or double precision (.d) operation.</p> <p>The 'z' bits select the target coprocessor.</p> <p>The 'd' bits select the destination register.</p> <p>The 'k' bits select the index.</p> <p>Note: Coprocessor select bit field zz = 2'b00 for floating-point coprocessor macro.</p>				
I-Words:	1				
SP Execute Cycles:	1				
DP Execute Cycles:	1				
Repetition Rate:	1				
Single Precision:					
	Index	Data	Description		
	31	32'H7FFF_FFFF	QNAN - RANGE ENDS		
	30	32'H7FC0_0000	QNAN - RANGE STARTS		
	29	32'H7FBF_FFFF	SNAN - RANGE ENDS		
	28	32'H7F80_0001	SNAN - RANGE STARTS		
	27	32'H7F80_0000	+INF		
	26	32'H7F7F_FFFF	+MAX MAG NORMAL		
	25	32'H0080_0000	+MIN MAG NORMAL		
	24	32'H007F_FFFF	+MAX MAG SUB-NORMAL		
	23	32'H0000_0001	+MIN MAG SUB-NORMAL		
	22	32'H0000_0000	+0.0		
	21	32'H8000_0000	-0.0		
	20	32'H8000_0001	-MIN MAG SUB-NORMAL		
	19	32'H807F_FFFF	-MAX MAG SUB-NORMAL		
	18	32'H8080_0000	-MIN MAG NORMAL		
	17	32'HFF7F_FFFF	-MAX MAG NORMAL		
	16	32'HFF80_0000	-INF		
	15	32'HFF80_0001	SNAN - RANGE STARTS		
	14	32'HFFBF_FFFF	SNAN - RANGE ENDS		
	13	32'HFFC0_0000	QNAN - RANGE STARTS		
	12	32'HFFFF_FFFF	QNAN - RANGE ENDS		
	11	32'H3F35_04F3	1/√2 = 0.70710...		
	10	32'H3FB5_04F3	√2 = 1.41421...		
	9	32'H4054_9A78	LOG2(10) = 3.321		
	8	32'H3F31_7218	LN(2) = 0.6931471 ...		
	7	32'H402D_F854	E = 2.71828...		
	6	32'H3F49_0FDB	Π/4 = 0.785398...		
	5	32'H3FC9_0FDB	Π/2 = 1.5707...		

Floating-Point Instruction Description (continued)

MOVC	Move Constant Value to Fd	
4	32'H4049_0FDB	$\Pi = 3.14159...$
3	32'H40C9_0FDB	$2\Pi = 6.283185...$
2	32'H4000_0000	2.0
1	32'H3F80_0000	1.0
0	32'H4120_0000	10.0

Double Precision:

Index	Data	Description
31	64'H7FFF_FFFF_FFFF_FFFF	QNaN - RANGE ENDS
30	64'H7FF8_0000_0000_0000	QNaN RANGE STARTS
29	64'H7FF7_FFFF_FFFF_FFFF	SNAN RANGE ENDS
28	64'H7FF0_0000_0000_0001	SNAN RANGE STARTS
27	64'H7FF0_0000_0000_0000	+INF
26	64'H7FEF_FFFF_FFFF_FFFF	+MAX MAG NORMAL
25	64'H0010_0000_0000_0000	+MIN MAG NORMAL
24	64'H000F_FFFF_FFFF_FFFF	+MAX MAG SUB-NORMAL
23	64'H0000_0000_0000_0001	+MIN MAG SUB-NORMAL
22	64'H0000_0000_0000_0000	+0.0
21	64'H8000_0000_0000_0000	-0.0
20	64'H8000_0000_0000_0001	-MIN MAG SUB-NORMAL
19	64'H800F_FFFF_FFFF_FFFF	-MAX MAG SUB-NORMAL
18	64'H8010_0000_0000_0000	-MIN MAG NORMAL
17	64'HFFEF_FFFF_FFFF_FFFF	-MAX MAG NORMAL
16	64'HFFF0_0000_0000_0000	-INF
15	64'HFFF0_0000_0000_0001	SNAN RANGE STARTS
14	64'HFFF7_FFFF_FFFF_FFFF	SNAN RANGE ENDS
13	64'HFFF8_0000_0000_0000	QNaN RANGE STARTS
12	64'HFFFF_FFFF_FFFF_FFFF	QNaN RANGE ENDS
11	64'H3FE6_A09E_667F_3BCD	$1/\sqrt{2}=0.7071...$
10	64'H3FF6_A09E_667F_3BCD	$\sqrt{2}=1.41421..$
9	64'H400A_934F_0979_A371	$\text{LOG}_2(10)= 3.321$
8	64'H3FE6_2E42_FEFA_39EF	$\text{LN}(2)=0.69314$
7	64'H4005_BF0A_8B14_5769	$E = 2.71828...$
6	64'H3FE9_21FB_5444_2D18	$\pi/4= 0.7853...$
5	64'H3FF9_21FB_5444_2D18	$\pi/2 = 1.5707..$
4	64'H4009_21FB_5444_2D18	$\pi = 3.14159...$
3	64'H4019_21FB_5444_2D18	$2\pi = 6.28...$
2	64'H4000_0000_0000_0000	2.0
1	64'H3FF0_0000_0000_0000	1.0
0	64'H4024_0000_0000_0000	10.0

Example:1	MOVC.s #3, F0	;Move single precision constant 2π to register F0
	Before execution	After execution
	F0 0x00000000	F0 0x40C90FDB

Example:2	MOVC.d #8, F0	;Move double precision constant $\text{Ln}(2)$ to register F1:F0
	Before execution	After execution

Floating-Point Instruction Description (continued)

Example:2	MOVC.d #8, F0		;Move double precision constant Ln(2) to register F1:F0	
	F1:F0	0x000000000000 0000	F1:F0	0x3FE62E42FEFA39EF

MOV		Move Coprocessor Register to Wd			
Syntax:	{label;} MOV.l	Fs,	Wd		
		FSR,	[Wd]		
		FSRH,	[Wd++]		
		FCR,	[Wd--]		
		FEAR,	[--Wd]		
			[++Wd]		
			[Wd+Wb]		
Operands:	Fs ∈ [F0 ... F31]; Wd ∈ [W0 ... W15]; Wb ∈ [W0 ... W14] (see Note 2)				
Operation:	(Fs or FSR or FSRH or FCR or FEAR) → (EAd)				
Status Affected:	None				
Encoding:	S000	011s	ssss	dddd	UUUq qqww wwRU zz00
Description:	<p>Move the contents of the source coprocessor data, status or control register into the destination register. Syntax shown is for the floating-point coprocessor registers.</p> <p>The 'S' bit selects instruction size.</p> <p>The 'z' bits select the target coprocessor.</p> <p>The 's' bits select the coprocessor source register.</p> <p>The 'd' bits select the destination register.</p> <p>The 'q' bits select the destination addressing mode.</p> <p>The 'w' bits define the offset Wb.</p> <p>The 'R' bit selects between the F-regs and FPU special registers.</p> <p>Notes:</p> <ol style="list-style-type: none"> 1. This instruction operates in Long Word mode only. 2. Stack Pointer (W15) limit checks are only performed for Wd = W15. Consequently, setting Wb = W15 is not permitted. 				
I-Words:	1 or 0.5				
Cycles:	1				

MOV	Move Wns with Signed Literal Offset to Coprocessor Register							
Syntax:	{label:}	MOV.l	[Wns+Slit14], Fd					
Operands:	Wns ∈ [W0 ... W15] Fd ∈ [F0 ... F31]							
Operation:	[Wns+Slit14] → Fd							
Status Affected:	None							
Encoding:	1000	010d	dddd	ssss	kkkk	kkkk	kkkk	zz01
Description:	<p>Moves contents of the source Effective Address into the destination register. Syntax shown is for the floating-point coprocessor F-reg. The contents of Wns are not modified by this operation. The instruction encoding includes space for a 12-bit literal which is scaled accordingly for long word data moves in order to generate the corresponding byte offset value.</p> <p>The 'z' bits select the target coprocessor.</p> <p>The 's' bits select the source register.</p> <p>The 'd' bits select the floating-point destination register.</p> <p>Notes:</p> <ol style="list-style-type: none"> 1. This instruction only supported when a coprocessor is instantiated. 2. This instruction operates in Long Word mode only. 							
I-Words:	1							
Cycles:	1							

MOV		Move Ws to Coprocessor Register						
Syntax:	{label:}	MOV.l	Ws, [Ws], [Ws++] [Ws--] [--Ws], [++Ws], [Ws+Wb],	Fd FSR FCR FEAR				
Operands:	Fd ∈ [F0 ... F31]; Ws ∈ [W0 ... W15]; Wb ∈ [W0 ... W14] (see Note 2)							
Operation:	(EAs) → Fd, FSR, FCR or FEAR							
Status Affected:	None							
Encoding:	s000	010d	dddd	ssss	pppŪ	ŪŪww	wwRU	zz00
Description:	<p>Move the contents of the source register into the coprocessor destination data, status or control register. Syntax shown is for the floating-point coprocessor registers.</p> <p>The 'S' bit selects instruction size.</p> <p>The 'z' bits select the target coprocessor.</p> <p>The 's' bits select the source register.</p> <p>The 'd' bits select the coprocessor destination register.</p> <p>The 'p' bits select the source addressing mode.</p> <p>The 'w' bits define the offset Wb.</p> <p>The 'R' bit selects between the F-regs and FPU special registers.</p> <p>Notes:</p> <ol style="list-style-type: none"> 1. This instruction operates in Long Word mode only. 2. Stack Pointer (W15) limit checks are only performed for Wd = W15. Consequently, setting Wb = W15 is not permitted. 							
I-Words:	1 or 0.5							
Cycles:	1							

MOV		Move Long Literal to Coprocessor Register						
Syntax:	{label:}	MOV.l	lit32,	Fd				
				FSR				
				FCR				
Operands:		lit32 ∈ [0 ... 4GB]; Fd ∈ [F0 ... F31]						
Operation:		lit32 → (Fd or FSR or FCR)						
Status Affected:		None						
Encoding:								
1st word		1000	001z	kkkk	kkkk	kkkk	kkkk	z001
2nd word		1000	001d	dddd	Ukkk	kkkU	UUkk	kkkk R101
Description:		<p>The literal 'k' is loaded into the coprocessor destination data register. Syntax shown is for the floating-point coprocessor register.</p> <p>The 'd' bits select the coprocessor destination register.</p> <p>The 'z' bits select the target coprocessor.</p> <p>zz[1:0] = Word1[24], Word1[3]</p> <p>The 'R' bit selects between the F-regs and FPU special registers.</p> <p>The 'k' bits specify the value of the 32-bit literal:</p> <p>lit32[31:0] = Word1[18:13], Word2[9:4], Word1[23:4]</p>						
I-Words:		2						
Cycles:		2						

MUL		Floating-Point Signed Multiply							
Syntax:	{label:}	MUL.s	Fb,	Fs,	Fd				
		MUL.d							
Operands (.s):		Fs ∈ [F0 ... F31]; Fb ∈ [F0 ... F31]; Fd ∈ [F0 ... F31]							
Operands (.d):		Fs ∈ [F0, F2 ... F30]; Fb ∈ [F0, F2 ... F30]; Fd ∈ [F0, F2 ... F30]							
Operation:		(Fb) * (Fs) → Fd;							
Status Affected:		SUBO, INX, UDF, OVF, INVAL (see Note 1)							
Exceptions Possible:		SUBO, INX, UDF, OVF, INVAL							
Encoding:		1000	010P	zzdd	ddds	ssss	www	wUUU	0110
Description:		<p>Multiply the signed contents of the source register Fb with the signed contents of the source register Fs, then write the product to Fd. (0 * ∞) or (∞ * 0) will result in distinguished qNaN and signal an INVAL exception. The 'P' bit selects single (.s) or double precision (.d) operation. The 'z' bits select the target coprocessor. The 's' bits select the source register. The 'w' bits select the base register. The 'd' bits select the destination register.</p> <p>Notes:</p> <ol style="list-style-type: none"> If not already set, the corresponding sticky exception status will also be set. Coprocessor select bit field zz = 2'b00 for floating-point coprocessor macro. 							
I-Words:		1							
SP Execute Cycles:		3							
DP Execute Cycles:		3							
Repetition Rate:		1							

Example:1 MUL.s F0, F1, F3 ;Multiply contents of F0 and F1 and store result in F3

Before execution		After execution	
F0	0x41200000	F0	0x41200000
F1	0x41C80000	F1	0x41C80000
F3	0x00000000	F3	0x437A0000
FSR[7:0]	8'b00000000	FSR[7:0]	8'b00000000

Example:2 MUL.d F0, F2, F6 ;Multiply contents of F1:F0 and F3:F2 and store result in F7:F6

Before execution		After execution	
F1:F0	0xFFE0000000000030	F1:F0	0xFFE0000000000030
F3:F2	0xFFE0000000000030	F3:F2	0xFFE0000000000030
F7:F6	0x0000000000000000	F7:F6	0x7FEFFFFFFF0000FFFF
FSR[7:0]	8'b00000000	FSR[7:0]	8'b00010100 (OVF, INX)

NEG		Negate Fs							
Syntax:	{label:}	NEG.s	Fs,	Fd					
		NEG.d							
Operands (.s):		Fs ∈ [F0 ... F31]; Fd ∈ [F0 ... F31]							
Operands (.d):		Fs ∈ [F0, F2 ... F30]; Fd ∈ [F0, F2 ... F30]							
Operation:		-Fs → Fd							
Status Affected:		SUBO ¹							
Exceptions Possible:		SUBO							
Encoding:		1000	100P	zzdd	ddds	ssss	UUUU	UUUU	0110
Description:		Negate the sign of the contents of the source register Fs and place the result in the destination register Fd. The 'P' bit selects single (.s) or double precision (.d) operation. The 'z' bits select the target coprocessor. The 's' bits select the source register. The 'd' bits select the destination register.							
		Notes:							
		1. If not already set, the corresponding sticky exception status will also be set.							
		2. Coprocessor select bit field zz = 2'b00 for floating-point coprocessor macro.							
I-Words:		1							
SP Execute Cycles:		1							
DP Execute Cycles:		1							
Repetition Rate:		1							

Note: This instruction only affects the sign bit and will not quit an sNaN input operand.

Example:1	NEG.s F0, F3	;Find negate of a number in F0 and store result in F3	
		Before execution	After execution
		F0 0x40800001	F0 0x40800001
		F3 0x00000000	F3 0xC0800001
		FSR[7:0] 8'b00000000	FSR[7:0] 8'b00000000
Example:2	NEG.d F0, F2	;Find negate of a number in F1:F0 and store result in F3:F2	
		Before execution	After execution
		F1:F0 0x800000000000 00001	F1:F0 0x800000000000 00001
		F3:F2 0x000000000000 00000	F3:F2 0x000000000000 00001
		FSR[7:0] 8'b00000000	FSR[7:0] 8'b01000000 (SUBO)

POP		Pop FPU Coprocessor Register	
Syntax:	{label;} POP.I	Fd	FSR FCR FEAR
Operands:	Fd ∈ [F0 ... F31]		
Operation:	(W15)-4 → W15 (TOS) → (Fd or FSR or FCR or FEAR)		
Status Affected:	None		
Encoding:	0010	111d	dddd zzRU
Description:	<p>Move the top of system stack to the coprocessor destination register. Use of the system Stack Pointer ([-W15]) is implied. Syntax shown is for the floating-point coprocessor registers. The 'd' bits select the floating point destination register.</p> <p>The 'z' bits select the target coprocessor.</p> <p>The 'R' bit selects between the F-regs and FPU special registers.</p> <p>Notes:</p> <ol style="list-style-type: none"> 1. This instruction operates in Long Word mode only. 2. FSRH not supported as it would clear exception status in FSR[15:0]. 		
Words:	1		
Cycles:	1		

PUSH		Push FPU Coprocessor Register	
Syntax:	{label:}	PUSH.l	Fs FSR FSRH FCR FEAR
Operands:	Fs ∈ [F0 ... F31]		
Operation:	(Fs or FSR or FSRH or FCR or FEAR) → (TOS) (W15)+4 → W15		
Status Affected:	None		
Encoding:	0010	011s	ssss zzRU
Description:	<p>Move the contents of the source floating point register to the top of system stack. Use of the system Stack Pointer ([W15++]) is implied. Syntax shown is for the floating-point coprocessor registers. When FSRH is selected, long word value {FSR[31:16], 16'b0} will be pushed onto the stack. FSR[31:16] comprises of FCPS/FCPQ and FTST instruction status only.</p> <p>The 's' bits select the floating point source register.</p> <p>The 'z' bits select the target coprocessor.</p> <p>The 'R' bit selects between the F-regs and FPU special registers.</p> <p>Note:</p> <ol style="list-style-type: none"> This instruction operates in Long Word mode only. 		
Words:	0.5		
Cycles:	1		

SIN		Evaluate the Sine of Fs							
Syntax:	{label:}	SIN.s	Fs,	Fd					
Operands (.s):	Fs ∈ [F0 ... F31]; Fd ∈ [F0 ... F31]								
Operation:	Sin(Fs) → Fd								
Status Affected:	SUBO, INX, UDF, INVAL (see Note 1)								
Exceptions Possible:	SUBO, INX, UDF, INVAL								
Encoding:	1000	110P	zzdd	ddds	ssss	UUUU	UUUU	0010	
Description:	<p>Calculate the sine of contents of the source register Fs (where $Fs = [2\pi k + \theta \text{ rads}]$), and place the result in the destination register Fd. The 'z' bits select the target coprocessor.</p> <p>The 's' bits select the source register</p> <p>The 'd' bits select the destination register.</p> <p>Notes:</p> <ol style="list-style-type: none"> If not already set, the corresponding sticky exception status will also be set. This operation is only supported using single precision floating-point. Coprocessor select bit field zz = 2'b00 for floating-point coprocessor macro. 								
I-Words:	1								
SP Execute Cycles:	4								
Repetition Rate:	1								

Example:1	SIN.s F0, F3	;Find Sine of radians in F0 and store result in F3					
		Before execution			After execution		
		F0	0x3F492492	F0	0x3F492492		
		F3	0x00000000	F3	0x3F351398		
		FSR[7:0]	8'b00000000	FSR[7:0]	8'b00000000		

Example:2	SIN.s F0, F3	;Find Sine of radians in F0 and store result in F3					
		Before execution			After execution		
		F0	0x7F800000	F0	0x7F800000		
		F3	0x00000000	F3	0x7FC00001	(distinguished qNaN)	
		FSR[7:0]	8'b00000000	FSR[7:0]	8'b00000001	(INVAL)	

SQRT		Square Root Fs, result in Fd							
Syntax:	{label:}	SQRT.s	Fs,	Fd					
		SQRT.d							
Operands (.s):		Fs ∈ [F0 ... F31]; Fd ∈ [F0 ... F31]							
Operands (.d):		Fs ∈ [F0, F2 ... F30]; Fd ∈ [F0, F2 ... F30]							
Operation:		$\sqrt{Fs} \rightarrow Fd$							
Status Affected:		SUBO, INX, INVAL (see Note 1)							
Exceptions Possible:		SUBO, INX, INVAL							
Encoding:		1000	100P	zzdd	ddds	ssss	UUUU	UUUU	1010
Description:		Take the square root of contents of the source register Fs, and place the result in the destination register Fd. If $Fs < 0$, destination will be written with distinguished qNaN and signal an FPU INVAL exception. The 'P' bit selects single (.s) or double precision (.d) operation. The 'z' bits select the target coprocessor. The 's' bits select the source register. The 'd' bits select the destination register.							
		Notes:							
		1. If not already set, the corresponding sticky exception status will also be set. 2. Coprocessor select bit field zz = 2'b00 for floating-point coprocessor macro.							
I-Words:		1							
SP Execute Cycles:		10							
DP Execute Cycles:		13							
Repetition Rate:		TBD							

Example:1	SQRT.s F0, F3	;Find Square root of number in F0 and store result in F3							
		Before execution				After execution			
		F0	0x00000030	F0	0x00000030				
		F3	0x00000000	F3	0x1B9CC470				
		FSR[7:0]	8'b00000000	FSR[7:0]	8'b00000000				

Example:2	SQRT.d F0, F2	;Find Square root of number in F1:F0 and store result in F3:F2							
		Before execution				After execution			
		F1:F0	0x4050000000000000	F1:F0	0x4050000000000000				
		F3:F2	0x0000000000000000	F3:F2	0x4020000000000000				
		FSR[7:0]	8'b00000000	FSR[7:0]	8'b00010000			(INX)	

SUB		Subtract Fs from Fb			
Syntax:	{label:} SUB.s Fb, Fs, Fd SUB.d				
Operands (.s):	Fs ∈ [F0 ... F31]; Fb ∈ [F0 ... F31]; Fd ∈ [F0 ... F31]				
Operands (.d):	Fs ∈ [F0, F2 ... F30]; Fb ∈ [F0, F2 ... F30]; Fd ∈ [F0, F2 ... F30]				
Operation:	Fb - Fs → Fd				
Status Affected:	SUBO, INX, UDF, OVF, INVAL (see Note 1)				
Exceptions Possible:	SUBO, INX, UDF, OVF, INVAL				
Encoding:	1000 000P zzdd ddds ssss wwww wUUU 0110				
Description:	<p>Subtract the contents of the source register Fs from the contents of the base register Fb, then place the result in the destination register Fd. (∞ - ∞) will result in distinguished qNaN and signal an FPU INVAL exception. The 'P' bit selects single (.s) or double precision (.d) operation. The 'z' bits select the target coprocessor. The 's' bits select the source register. The 'w' bits select the base register. The 'd' bits select the destination register.</p> <p>Notes:</p> <ol style="list-style-type: none"> If not already set, the corresponding sticky exception status will also be set. Coprocessor select bit field zz = 2'b00 for floating-point coprocessor macro. 				
I-Words:	1				
SP Execute Cycles:	2				
DP Execute Cycles:	2				
Repetition Rate:	1				

Example:1	SUB.s F0, F1, F3	;Subtracts F1 from F0 and stores the result in F3
	Before execution	After execution
	F0 0x40800001	F0 0x40800001
	F1 0xC0F800F1	F1 0xC0F800F1
	F3 0x00000000	F3 0xC07001E0
	FSR[7:0] 8'b00000000	FSR[7:0] 8'b00000000

Example:2	SUB.d F0, F2, F6	;Subtracts F3:F2 from F1:F0 and stores the result in F7:F6
	Before execution	After execution
	F1:F0 0x000FFFFFFFFF FFFF	F1:F0 0x000FFFFFFFFF FFFF
	F3:F2 0x000FFFFFFFFF FFFF	F3:F2 0x000FFFFFFFFF FFFF
	F7:F6 0x001FFFFFFFFF FFFE	F7:F6 0x001FFFFFFFFF FFFE
	FSR[7:0] 8'b00000000	FSR[7:0] 8'b01000000 (SUBO)

TST		Test Fs	
Syntax:	{label:}	TST.s	Fs
		TST.d	
Operands (.s):	Fs ∈ [F0 ... F31]		
Operands (.d):	Fs ∈ [F0, F2 ... F30]		
Operation:	If Fs is +/-Subnormal FSR.SUB = 1 else FSR.SUB = 0 If Fs is +/- Infinity FSR.INF = 1 else FSR.INF = 0 If Fs is Negative FSR.FN = 1 else FSR.FN = 0 If Fs is +/- Zero FSR.FZ = 1 else FSR.FZ = 0 If Fs is qNaN or sNaN FSR.FNAN = 1 else FSR.FNAN = 0		
Status Affected:	SUB, INF, FN, FZ, FNAN		
Exceptions Possible:	None		
Encoding:	1001	010P	zzUU UUU _s ssss UUUU UUUU 0010
Description:	Inspect the contents of Fs and set the FSR status accordingly. The 'P' bit selects single (.s) or double precision (.d) operation. The 'z' bits select the target coprocessor. The 's' bits select the source register. Note: Coprocessor select bit field zz = 2'b00 for floating-point coprocessor macro.		
I-Words:	1		
SP Execute Cycles:	1		
DP Execute Cycles:	1		
Repetition Rate:	1		

Example:1 TST.s F0 ;Inspects contents of F0 register and updates FSR

Before execution		After execution	
F0	0xFFC0000A (a -ve NaN number)	F0	0xFFC0000A
FSR[31:24]	8'b00000000	FSR[31:24]	8'b00000101 (FN, NAN)

Example:2 TST.d F0 ;Inspects contents of F1:F0 register and updates FSR

Before execution		After execution	
F1:F0	0xFFFF00000000 0000 (a -ve Inf number)	F1:F0	0xFFFF00000000 0000
FSR[31:24]	8'b00000000	FSR[31:24]	8'b00001100 (FN, INF)

5. Built-In Functions

5.1. Introduction

Built-in functions give the C programmer access to assembler operators or machine instructions that are currently only accessible using in-line assembly but are sufficiently useful that they are applicable in a broad range of applications. Built-in functions are coded in C source files syntactically like function calls, but they are compiled to assembly code that directly implements the function and does not involve function calls or library routines.

The built-in functions are preferred by programmers more than in-line assembly, for the following reasons :

1. Providing built-in functions for specific purposes simplifies coding.
2. Certain optimizations are disabled when in-line assembly is used as compared to built-in functions.
3. For machine instructions that use dedicated registers, coding with in-line assembly needs care to avoid register allocation errors . The built-in functions make this process simpler as user need not be concerned with the particular register requirements for each individual machine instruction.

The built-in functions are listed below followed by their individual detailed descriptions.

- [__builtin_addab](#)
- [__builtin_add](#)
- [__builtin_btg](#)
- [__builtin_clr](#)
- [__builtin_divf](#)
- [__builtin_divmodsd](#)
- [__builtin_divmodud](#)
- [__builtin_divsd](#)
- [__builtin_divud](#)
- [__builtin_dmaoffset](#)
- [__builtin_ed](#)
- [__builtin_edac](#)
- [__builtin_fbcl](#)
- [__builtin_lac](#)
- [__builtin_mac](#)
- [__builtin_modsd](#)
- [__builtin_modud](#)
- [__builtin_mpy](#)
- [__builtin_mpyn](#)
- [__builtin_msc](#)
- [__builtin_mulss](#)
- [__builtin_mulsu](#)
- [__builtin_mulus](#)
- [__builtin_muluu](#)

- [__builtin_nop](#)
- [__builtin_readsfr](#)
- [__builtin_return_address](#)
- [__builtin_sac](#)
- [__builtin_sacr](#)
- [__builtin_sftac](#)
- [__builtin_subab](#)

The compiler provides additional built-in functions for operations, such as writing to Flash program memory and changing the oscillator settings. Refer to the *MPLAB® C Compiler for dsPIC® DSCs User's Guide* (DS51284) for a complete list of compiler built-in functions.

5.2. Built-In Functions List

This section describes the programmer interface to the compiler built-in functions. Since the functions are “built-in”, there are no header files associated with them. Similarly, there are no command-line switches associated with the built-in functions; they are always available. The built-in function names are chosen such that they belong to the compiler’s namespace (they all have the prefix: `__builtin_`), so they will not conflict with function or variable names in the programmer’s namespace.

<code>__builtin_addab</code>
<p>Description: Adds Accumulators A and B with the result written back to the specified accumulator. For example:</p> <pre>register int result asm("A"); register int B asm("A"); result = __builtin_addab(result,B);</pre>
<p>will generate:</p> <pre>add A</pre>
<p>Prototype:</p> <pre>int __builtin_addab(int Accum_a, int Accum_b);</pre>
<p>Argument: <i>Accum_a</i> First accumulator to add. <i>Accum_b</i> Second accumulator to add.</p>
<p>Return Value: Returns the addition result to an accumulator.</p>
<p>Assembler Operator/Machine Instruction: add</p>
<p>Error Messages: An error message appears if the result is not an Accumulator register.</p>

<code>__builtin_add</code>
<p>Description: Adds <i>value</i> to the accumulator specified by <i>result</i> with a shift specified by literal shift. For example:</p> <pre>register int result asm("A"); int value; result = __builtin_add(result,value,0);</pre>
<p>If <i>value</i> is held in <i>w0</i>, the following will be generated:</p> <pre>add w0, #0, A</pre>

Built-In Functions List (continued)**_builtin_add****Prototype:**

```
int _builtin_add(int Accum,int value,
const int shift);
```

Argument:

Accum Accumulator to add.

value Integer number to add to accumulator value.

shift Amount to shift resultant accumulator value.

Return Value:

Returns the shifted addition result to an accumulator.

Assembler Operator/Machine Instruction:

add

Error Messages:

An error message appears if:

- The result is not an Accumulator register
- Argument 0 is not an accumulator
- The shift value is not a literal within range

_builtin_btg**Description:**

This function will generate a `btg` machine instruction. Some examples include:

```
int i; /* near by default */
int l _attribute__((far));
struct foo {
    int bit1:1;
} barbits;
int bar;
void some_bittoggles() {
    register int j asm("w9");
    int k;
    k = i;
    _builtin_btg(&i,1);
    _builtin_btg(&j,3);
    _builtin_btg(&k,4);
    _builtin_btg(&l,11);
    return j+k;
}
```

Note that taking the address of a variable in a register will produce a warning by the compiler and cause the register to be saved onto the stack (so that its address may be taken); this form is not recommended. This caution only applies to variables explicitly placed in registers by the programmer.

Prototype:

```
void _builtin_btg(unsigned int *, unsigned int 0xn);
```

Argument:

* A pointer to the data item for which a bit should be toggled.

0xn A literal value in the range of 0 to 15.

Return Value:

Returns a `btg` machine instruction.

Assembler Operator/Machine Instruction:

btg

Error Messages:

An error message appears if the parameter values are not within range.

_builtin_clr**Description:**

Clears the specified accumulator. For example:

```
register int result asm("A");
result = _builtin_clr();
```

will generate:

```
clr A
```

Prototype:

```
int _builtin_clr(void);
```

Argument:

None.

Return Value:

Returns the cleared value result to an accumulator.

Assembler Operator/Machine Instruction:

clr

Error Messages:

An error message appears if the result is not an Accumulator register.

_builtin_divf**Description:**

Computes the quotient: num / den . A math error exception occurs if den is zero. Function arguments are unsigned, as is the function result.

Prototype:

```
unsigned int _builtin_divf(unsigned int num,
unsigned int den);
```

Argument:

num Numerator.

den Denominator.

Return Value:

Returns the unsigned integer value of the quotient: num / den .

Assembler Operator/Machine Instruction:

div.f

_builtin_divmodsd**Description:**

Issues the 16-bit architecture's native signed divide support. Notably, if the quotient does not fit into a 16-bit result, the results (including remainder) are unexpected. This form of the built-in function will capture both the quotient and remainder.

Prototype:

```
signed int _builtin_divmodsd(
signed long dividend, signed int divisor,
signed int *remainder);
```

Argument:

$dividend$ Number to be divided.

$divisor$ Number to divide by.

$remainder$ Pointer to remainder.

Return Value:

Quotient and remainder.

Built-In Functions List (continued)**_builtin_divmodsd****Assembler Operator/Machine Instruction:**

divmodsd

Error Messages:

None.

_builtin_divmodud**Description:**

Issues the 16-bit architecture's native unsigned divide support. Notably, if the quotient does not fit into a 16-bit result, the results (including remainder) are unexpected. This form of the built-in function will capture both the quotient and remainder.

Prototype:

```
unsigned int  _builtin_divmodud(
unsigned long dividend, unsigned int divisor,
unsigned int *remainder);
```

Argument:

dividend Number to be divided.

divisor Number to divide by.

remainder Pointer to remainder.

Return Value:

Quotient and remainder.

Assembler Operator/Machine Instruction:

divmodud

Error Messages:

None.

_builtin_divsd**Description:**

Computes the quotient: num / den . A math error exception occurs if *den* is zero. Function arguments are signed, as is the function result. The command-line option, `-wconversions`, can be used to detect unexpected sign conversions.

Prototype:

```
int _builtin_divsd(const long num, const int den);
```

Argument:

num Numerator.

den Denominator.

Return Value:Returns the signed integer value of the quotient: num / den .**Assembler Operator/Machine Instruction:**

div.sd

_builtin_divud**Description:**

Computes the quotient: num / den . A math error exception occurs if *den* is zero. Function arguments are unsigned, as is the function result. The command-line option, `-wconversions`, can be used to detect unexpected sign conversions.

Prototype:

```
unsigned int  _builtin_divud(const unsigned
long num, const unsigned int den);
```

Built-In Functions List (continued)**_builtin_divud****Argument:***num* Numerator.*den* Denominator.**Return Value:**Returns the unsigned integer value of the quotient: *num* / *den*.**Assembler Operator/Machine Instruction:**

div.ud

_builtin_dmaoffset**Description:**

Obtains the offset of a symbol within DMA memory.

For example:

```
unsigned int    result;
char    buffer[256] __attribute__((space(dma)));
result = _builtin_dmaoffset(&buffer);
```

May generate:

```
mov #dmaoffset(buffer), w0
```

Prototype:

```
unsigned int _builtin_dmaoffset(const void *p);
```

Argument:**p* Pointer to DMA address value.**Return Value:**

Returns the offset to a variable located in DMA memory.

Assembler Operator/Machine Instruction:

dmaoffset

Error Messages:

An error message appears if the parameter is not the address of a global symbol.

_builtin_ed**Description:**Squares *sqr*, returning it as the result. Also prefetches data for future square operation by computing ***xptr - **yptr* and storing the result in **distance*.*xincr* and *yincr* may be the literal values: -6, -4, -2, 0, 2, 4, 6 or an integer value.

For example:

```
register int result asm("A");
int    *xmemory, *ymemory;
int    distance;
result = _builtin_ed(distance,
                    &xmemory, 2,
                    &ymemory, 2,
                    &distance);
```

May generate:

```
ed w4*w4, A, [w8]+=2, [W10]+=2, w4
```

Built-In Functions List (continued)**_builtin_ed****Prototype:**

```
int _builtin_ed(int sqr, int **xptr, int xincr,
int **yptr, int yincr, int *distance);
```

Argument:

sqr Integer squared value.

xptr Integer Pointer to pointer to X prefetch.

xincr Integer increment value of X prefetch.

yptr Integer Pointer to pointer to Y prefetch.

yincr Integer increment value of Y prefetch.

distance Integer Pointer to distance.

The arguments, *xptr* and *yptr*, must point to the arrays located in the X data memory and Y data memory, respectively.

Return Value:

Returns the squared result to an accumulator.

Assembler Operator/Machine Instruction:

```
ed
```

Error Messages:

An error message appears if:

- The result is not an Accumulator register
- *xptr* is null
- *yptr* is null
- *distance* is null

_builtin_edac**Description:**

Squares *sqr* and sums with the nominated Accumulator register, returning it as the result. Also prefetches data for future square operation by computing ***xptr - **yptr* and storing the result in **distance*.

xincr and *yincr* may be the literal values: -6, -4, -2, 0, 2, 4, 6 or an integer value.

For example:

```
register int result asm("A");
int *xmemory, *ymemory;
int distance;
result = _builtin_ed(result, distance,
                    &xmemory, 2,
                    &ymemory, 2,
                    &distance);
```

May generate:

```
edac w4*w4, A, [w8]+=2, [W10]+=2, w4
```

Prototype:

```
int _builtin_edac(int Accum, int sqr,
int **xptr, int xincr, int **yptr, int yincr,
int *distance);
```

Built-In Functions List (continued)**_builtin_edac****Argument:**

Accum Accumulator to sum.

sqr Integer squared value.

xptr Integer Pointer to pointer to X prefetch.

xincr Integer increment value of X prefetch.

yptr Integer Pointer to pointer to Y prefetch.

yincr Integer increment value of Y prefetch.

distance Integer Pointer to distance.

The arguments, *xptr* and *yptr*, must point to the arrays located in the X data memory and Y data memory, respectively.

Return Value:

Returns the squared result to specified accumulator.

Assembler Operator/Machine Instruction:

```
edac
```

Error Messages:

An error message appears if:

- The result is not an Accumulator register
- *Accum* is not an Accumulator register
- *xptr* is null
- *yptr* is null
- *distance* is null

_builtin_fbcl**Description:**

Finds the first bit change from left in value. This is useful for dynamic scaling of fixed-point data. For example:

```
int result, value;
result = _builtin_fbcl(value);
```

May generate:

```
fbcl w4, w5
```

Prototype:

```
int _builtin_fbcl(int value);
```

Argument:

value Integer number of first bit change.

Return Value:

Returns the shifted addition result to an accumulator.

Assembler Operator/Machine Instruction:

```
fbcl
```

Error Messages:

An error message appears if the result is not an Accumulator register.

_builtin_lac**Description:**

Shifts value by *shift* (a literal between -8 and 7) and returns the value to be stored into the Accumulator register. For example:

```
register int result asm("A");
int      value;
result = _builtin_lac(value,3);
```

May generate:

```
lac w4, #3, A
```

Prototype:

```
int _builtin_lac(int value, int shift);
```

Argument:

value Integer number to be shifted.

shift Literal amount to shift.

Return Value:

Returns the shifted addition result to an accumulator.

Assembler Operator/Machine Instruction:

```
lac
```

Error Messages:

An error message appears if:

- The result is not an Accumulator register
- The shift value is not a literal within range

_builtin_mac**Description:**

Computes $a \times b$ and sums with the accumulator; it also prefetches data ready for a future MAC operation.

xptr may be null to signify no X prefetch to be performed; in which case, the values of *xincr* and *xval* are ignored but required.

yptr may be null to signify no Y prefetch to be performed; in which case, the values of *yincr* and *yval* are ignored but required.

xval and *yval* nominate the address of a C variable where the prefetched value will be stored.

xincr and *yincr* may be the literal values: -6, -4, -2, 0, 2, 4, 6 or an integer value.

If *AWB* is non-null, the other accumulator will be written back into the referenced variable.

For example:

```
register int result asm("A");
register int B asm("B");
int      *xmemory;
int      *ymemory;
int      xVal, yVal;
result = _builtin_mac(result, xVal, yVal,
                      &xmemory, &xVal, 2,
                      &ymemory, &yVal, 2, 0, B);
```

May generate:

```
mac w4*w5, A, [w8]+=2, w4, [w10]+=2, w5
```

Prototype:

```
int _builtin_mac(int Accum, int a, int b,
int **xptr, int *xval, int xincr,
int **yptr, int *yval, int yincr, int *AWB,
int AWB_accum);
```

Built-In Functions List (continued)**_builtin_mac****Argument:**

Accum Accumulator to sum.

a Integer multiplicand.

b Integer multiplier.

xptr Integer Pointer to pointer to X prefetch.

xval Integer Pointer to value of X prefetch.

xincr Integer increment value of X prefetch.

yptr Integer Pointer to pointer to Y prefetch.

yval Integer Pointer to value of Y prefetch.

yincr Integer increment value of Y prefetch.

AWB Accumulator Write-Back location.

AWB_accum Accumulator to Write-Back.

The arguments, *xptr* and *yptr*, must point to the arrays located in the X data memory and Y data memory, respectively.

Return Value:

Returns the cleared value result to an accumulator.

Assembler Operator/Machine Instruction:

```
mac
```

Error Messages:

An error message appears if:

- The result is not an Accumulator register
- *Accum* is not an Accumulator register
- *xval* is a null value but *xptr* is not null
- *yval* is a null value but *yptr* is not null
- *AWB_accum* is not an Accumulator register and *AWB* is not null

_builtin_modsd**Description:**

Issues the 16-bit architecture's native signed divide support. Notably, if the quotient does not fit into a 16-bit result, the results (including remainder) are unexpected. This form of the built-in function will capture only the remainder.

Prototype:

```
signed int _builtin_modsd(signed long dividend,
signed int divisor);
```

Argument:

dividend Number to be divided.

divisor Number to divide by.

Return Value:

Remainder.

Assembler Operator/Machine Instruction:

```
modsd
```

Error Messages:

None.

_builtin_modud**Description:**

Issues the 16-bit architecture's native unsigned divide support. Notably, if the quotient does not fit into a 16-bit result, the results (including remainder) are unexpected. This form of the built-in function will capture only the remainder.

Built-In Functions List (continued)**_builtin_modud****Prototype:**

```
unsigned int _builtin_modud(unsigned long dividend,
unsigned int divisor);
```

Argument:

dividend Number to be divided.

divisor Number to divide by.

Return Value:

Remainder.

Assembler Operator/Machine Instruction:

```
modud
```

Error Messages:

None.

_builtin_mpy**Description:**

Computes $a \times b$; also, prefetches data ready for a future MAC operation.

xptr may be null to signify no X prefetch to be performed; in which case, the values of *xincr* and *xval* are ignored but required.

yptr may be null to signify no Y prefetch to be performed; in which case, the values of *yincr* and *yval* are ignored but required.

xval and *yval* nominate the address of a C variable where the prefetched value will be stored.

xincr and *yincr* may be the literal values: -6, -4, -2, 0, 2, 4, 6 or an integer value.

For example:

```
register int result asm("A");
int      *xmemory;
int      *ymemory;
int      xVal, yVal;
result = _builtin_mpy(xVal, yVal,
                     &xmemory, &xVal, 2,
                     &ymemory, &yVal, 2);
```

May generate:

```
mac w4*w5, A, [w8]+=2, w4, [w10]+=2, w5
```

Prototype:

```
int _builtin_mpy(int a, int b,
int **xptr, int *xval, int xincr,
int **yptr, int *yval, int yincr);
```

Argument:

a Integer multiplicand.

b Integer multiplier.

xptr Integer Pointer to pointer to X prefetch.

xval Integer Pointer to value of X prefetch.

xincr Integer increment value of X prefetch.

yptr Integer Pointer to pointer to Y prefetch.

yval Integer Pointer to value of Y prefetch.

yincr Integer increment value of Y prefetch.

AWB Integer Pointer to accumulator selection.

The arguments *xptr* and *yptr* must point to the arrays located in the X data memory and the Y data memory, respectively.

Built-In Functions List (continued)**_builtin_mpy****Return Value:**

Returns the cleared value result to an accumulator.

Assembler Operator/Machine Instruction:

```
mpy
```

Error Messages:

An error message appears if:

- The result is not an Accumulator register
- *xval* is a null value but *xptr* is not null
- *yval* is a null value but *yptr* is not null

_builtin_mpy_n**Description:**

Computes $-a \times b$; also, prefetches data ready for a future MAC operation.

xptr may be null to signify no X prefetch to be performed; in which case, the values of *xincr* and *xval* are ignored but required.

yptr may be null to signify no Y prefetch to be performed; in which case, the values of *yincr* and *yval* are ignored but required.

xval and *yval* nominate the address of a C variable where the prefetched value will be stored.

xincr and *yincr* may be the literal values: -6, -4, -2, 0, 2, 4, 6 or an integer value.

For example:

```
register int result asm("A");
int      *xmemory;
int      *ymemory;
int      xVal, yVal;
result = _builtin_mpy(xVal, yVal,
                    &xmemory, &xVal, 2,
                    &ymemory, &yVal, 2);
```

May generate:

```
mac w4*w5, A, [w8] +=2, w4, [w10] +=2, w5
```

Prototype:

```
int _builtin_mpy_n(int a, int b,
int **xptr, int *xval, int xincr,
int **yptr, int *yval, int yincr);
```

Argument:

a Integer multiplicand.

b Integer multiplier.

xptr Integer Pointer to pointer to X prefetch.

xval Integer Pointer to value of X prefetch.

xincr Integer increment value of X prefetch.

yptr Integer Pointer to pointer to Y prefetch.

yval Integer Pointer to value of Y prefetch.

yincr Integer increment value of Y prefetch.

AWB Integer Pointer to accumulator selection.

The arguments *xptr* and *yptr* must point to the arrays located in the X data memory and the Y data memory, respectively.

Return Value:

Returns the cleared value result to an accumulator.

Built-In Functions List (continued)**_builtin_mbyn****Assembler Operator/Machine Instruction:**

mbyn

Error Messages:

An error message appears if:

- The result is not an Accumulator register
- *xval* is a null value but *xptr* is not null
- *yval* is a null value but *yptr* is not null

_builtin_msc**Description:**Computes $a \times b$ and subtracts from accumulator; also, prefetches data ready for a future MAC operation.*xptr* may be null to signify no X prefetch to be performed; in which case, the values of *xincr* and *xval* are ignored but required.*yptr* may be null to signify no Y prefetch to be performed; in which case, the values of *yincr* and *yval* are ignored but required.*xval* and *yval* nominate the address of a C variable where the prefetched value will be stored.*xincr* and *yincr* may be the literal values: -6, -4, -2, 0, 2, 4, 6 or an integer value.If *AWB* is non-null, the other accumulator will be written back into the referenced variable.

For example:

```
register int result asm("A");
int      *xmemory;
int      *ymemory;
int      xVal, yVal;
result = _builtin_msc(result, xVal, yVal,
                    &xmemory, &xVal, 2,
                    &ymemory, &yVal, 2, 0, 0);
```

May generate:

```
msc w4*w5, A, [w8]+=2, w4, [w10]+=2, w5
```

Prototype:

```
int _builtin_msc(int Accum, int a, int b,
int **xptr, int *xval, int xincr,
int **yptr, int *yval, int yincr, int *AWB,
int AWB_accum);
```

Argument:*Accum* Accumulator to sum.*a* Integer multiplicand.*b* Integer multiplier.*xptr* Integer Pointer to pointer to X prefetch.*xval* Integer Pointer to value of X prefetch.*xincr* Integer increment value of X prefetch.*yptr* Integer Pointer to pointer to Y prefetch.*yval* Integer Pointer to value of Y prefetch.*yincr* Integer increment value of Y prefetch.*AWB* Accumulator Write-Back location.*AWB_accum* Accumulator to Write-Back.The arguments *xptr* and *yptr* must point to the arrays located in the X data memory and the Y data memory, respectively.**Return Value:**

Returns the cleared value result to an accumulator.

Built-In Functions List (continued)**_builtin_msc****Assembler Operator/Machine Instruction:**

```
msc
```

Error Messages:

An error message appears if:

- The result is not an Accumulator register
- *Accum* is not an Accumulator register
- *xval* is a null value but *xptr* is not null
- *yval* is a null value but *yptr* is not null
- *AWB_accum* is not an Accumulator register and *AWB* is not null

_builtin_mulss**Description:**

Computes the product $p0 \times p1$. Function arguments are signed integers and the function result is a signed long integer. The command-line option, `-Wconversions`, can be used to detect unexpected sign conversions.

Prototype:

```
signed long _builtin_mulss(const signed int p0, const signed int p1);
```

Argument:

p0 Multiplicand.

p1 Multiplier.

Return Value:

Returns the signed long integer value of the product $p0 \times p1$.

Assembler Operator/Machine Instruction:

```
mul.ss
```

_builtin_mulsu**Description:**

Computes the product $p0 \times p1$. Function arguments are integers with mixed signs and the function result is a signed long integer. The command-line option, `-Wconversions`, can be used to detect unexpected sign conversions. This function supports the full range of addressing modes of the instruction, including Immediate mode for operand *p1*.

Prototype:

```
signed long _builtin_mulsu(const signed int p0, const unsigned int p1);
```

Argument:

p0 Multiplicand.

p1 Multiplier.

Return Value:

Returns the signed long integer value of the product $p0 \times p1$.

Assembler Operator/Machine Instruction:

```
mul.su
```

_builtin_mulus**Description:**

Computes the product $p0 \times p1$. Function arguments are integers with mixed signs and the function result is a signed long integer. The command-line option, `-Wconversions`, can be used to detect unexpected sign conversions. This function supports the full range of addressing modes of the instruction.

Built-In Functions List (continued)**_builtin_mulus****Prototype:**

```
signed long _builtin_mulus(const unsigned int p0, const signed int p1);
```

Argument:

p0 Multiplicand.

p1 Multiplier.

Return Value:

Returns the signed long integer value of the product $p0 \times p1$.

Assembler Operator/Machine Instruction:

```
mul.us
```

_builtin_muluu**Description:**

Computes the product $p0 \times p1$. Function arguments are unsigned integers and the function result is an unsigned long integer. The command-line option, `-Wconversions`, can be used to detect unexpected sign conversions. This function supports the full range of addressing modes of the instruction, including Immediate mode for operand *p1*.

Prototype:

```
unsigned long _builtin_muluu(const unsigned int p0, const unsigned int p1);
```

Argument:

p0 Multiplicand.

p1 Multiplier.

Return Value:

Returns the signed long integer value of the product $p0 \times p1$.

Assembler Operator/Machine Instruction:

```
mul.uu
```

_builtin_nop**Description:**

Generates a NOP instruction.

Prototype:

```
void _builtin_nop(void);
```

Argument:

None.

Return Value:

Returns a no operation (NOP).

Assembler Operator/Machine Instruction:

```
NOP
```

_builtin_readsfr**Description:**

Reads the SFR.

Prototype:

```
unsigned int _builtin_readsfr(const void *p);
```

Built-In Functions List (continued)**_builtin_read sfr****Argument:**

p Object address.

Return Value:

Returns the SFR.

Assembler Operator/Machine Instruction:

```
readsfr
```

_builtin_return_address**Description:**

Returns the return address of the current function or of one of its callers. For the *level* argument, a value of zero yields the return address of the current function, a value of one yields the return address of the caller of the current function, and so forth. When *level* exceeds the current stack depth, zero will be returned. This function should only be used with a non-zero argument for debugging purposes.

Prototype:

```
int _builtin_return_address (const int level);
```

Argument:

level Number of frames to scan up the call stack.

Return Value:

Returns the return address of the current function or of one of its callers.

Assembler Operator/Machine Instruction:

```
return_address
```

_builtin_sac**Description:**

Shifts value by *shift* (a literal between -8 and 7) and returns the value.

For example:

```
register int value asm("A");
int      result;
result = _builtin_sac(value,3);
```

May generate:

```
sac A, #3, w0
```

Prototype:

```
int _builtin_sac(int value, int shift);
```

Argument:

value Integer number to be shifted.

shift Literal amount to shift.

Return Value:

Returns the shifted result to an accumulator.

Assembler Operator/Machine Instruction:

```
sac
```

Built-In Functions List (continued)**_builtin_sac****Error Messages:**

An error message appears if:

- The result is not an Accumulator register
- The shift value is not a literal within range

_builtin_sacr**Description:**

Shifts value by *shift* (a literal between -8 and 7) and returns the value, which is rounded using the Rounding mode determined by the RND (CORCON<1>) control bit.

For example:

```
register int value asm("A");
int     result;
result = _builtin_sac(value,3);
```

May generate:

```
sacr A, #3, w0
```

Prototype:

```
int _builtin_sacr(int value, int shift);
```

Argument:

value Integer number to be shifted.

shift Literal amount to shift.

Return Value:

Returns the shifted result to the CORCON register.

Assembler Operator/Machine Instruction:

```
sacr
```

Error Messages:

An error message appears if:

- The result is not an Accumulator register
- The shift value is not a literal within range

_builtin_sftac**Description:**

Shifts accumulator by *shift*. The valid shift range is -16 to 16.

For example:

```
register int result asm("A");
int     i;
result = _builtin_sftac(result,i);
```

May generate:

```
sftac A, w0
```

Prototype:

```
int _builtin_sftac(int Accum, int shift);
```

Argument:

Accum Accumulator to shift.

shift Amount to shift.

Built-In Functions List (continued)**_builtin_sftac****Return Value:**

Returns the shifted result to an accumulator.

Assembler Operator/Machine Instruction:

```
sftac
```

Error Messages:

An error message appears if:

- The result is not an Accumulator register
- *Accum* is not an Accumulator register
- The shift value is not a literal within range

_builtin_subab**Description:**

Subtracts accumulators A and B with the result written back to the specified accumulator. For example:

```
register int result asm("A");
register int B asm("B");
result = _builtin_subab(result,B);
```

Will generate:

```
sub A
```

Prototype:

```
int _builtin_subab(int Accum_a, int Accum_b);
```

Argument:

Accum_a Accumulator from which to subtract.

Accum_b Accumulator to subtract.

Return Value:

Returns the subtraction result to an accumulator.

Assembler Operator/Machine Instruction:

```
sub
```

Error Messages:

An error message appears if the result is not an Accumulator register.

6. Reference

6.1. Instruction Bit Map

The CPU instruction opcode map for the dsPIC33A class of devices is shown in [Figure 6-1](#). The map comprises 4 x 64 slot “Quadrants,” each selected by a 2-bit opcode extension bit field within the (32-bit) instruction. Each instruction has a 6-bit opcode, selecting one of 64 opcodes within a Quadrant. The 16-bit instructions do not have the extension bit field but assume use of the default Quadrant 0. New instructions are highlighted in blue text, while unused slots are grayed out. The opcode map shows the instructions defined for the FPU coprocessor in green text.

Note: The complete opcode for each instruction can be determined by the instruction descriptions in [Instruction Descriptions](#).

Figure 6-1. Instruction Encoding

Col Ref →	OpCode Size	OpCode Extension	OpCode (Sbits → MSbits)	0	1	2	3	4	5	6	7	8	9	10	11	12	13	14	15				
a	16/32-bit	00	0000	NECP (16-bit only)	MOV (W → W)	MOV (W → F)	MOV (F → W)	MOV (W ← W) (W ← W) (W ← W) (W ← W)	MOV (W ← W) (W ← W) (W ← W) (W ← W)	MOV (W ← W) (W ← W) (W ← W) (W ← W)	MOV (W ← W) (W ← W) (W ← W) (W ← W)	MOV (W ← W) (W ← W) (W ← W) (W ← W)	MULSS	MULLSU	MULLSU	MULLSU	POP (16-bit only)	PUSH (16-bit only)					
b			01	ASR by Short Lit	LSR by Short Lit	SL by Short Lit	PUSH Co-processor	ASR	LSR	SL	POP Co-processor	RLC	RLNC	RRC	RRNC	CP #13	CPB #13	CP	CPB				
c			10	BCLR	BSET	BTG	BTST	BTSPS	BSW	BTST Win with Wb													
d			11	ADD	ADDC	SUB	SUBB	AND	IOR	SJER	SJERR	XOR	Inherent	ADD IHS	SUB IHS	COM	SLEB #7	SE	ZE				
e	32-bit	01	00	MOVJ lit32	MOVJ lit32	MOVJ lit32	MOVJ lit32	MOVJ lit32	MOVJ lit32	MOVJ lit32	MOVJ lit32	MOVJ lit32	MOVJ lit32	MOVJ lit32	MOVJ lit32	MOVJ lit32	MOVJ lit32	MOVJ lit32	MOVJ lit32	MOVJ lit32	MOVJ lit32		
f			01	ASR	LSR	SL	CLR	CP0	CP	CPB	SET	RLC	RLNC	RRC	RRNC	DTB	MUL	POP	PUSH				
g			10	BCLR	BSET	BTG	BTST	BTSPS	BPNS lit16	BPNS	BPEXT			TST	INC	DEC	COM	NEG	INCF	DECF			
h			11	ADD	ADDF	SUBW	SUBB	AND	IOR	SUB	SUBB	XORW											
i	32-bit	10	00	FADD	FMAX	FMIN	FMIN2	FMOV	FMOV	FABS	FNEG	FNEG	FNEG	FNEG	FNEG	FNEG	FNEG	FNEG	FNEG	FNEG	FNEG		
j			01					BGA	BGB	BGB	BGB	BGB	BGB	BGB	BGB	BGB	BGB	BGB	BGB	BGB	BGB	BGB	
k			10	ADD lit16 and Wn	ADD lit16 and Wn	SUB lit16 and Wn	SUBB lit16 and Wn	AND lit16 and Wn	IOR lit16 and Wn	RET lit16 and Wn				XOR lit16 and Wn	RCALL REPEAT LINK	BRA CALL GOTO CALL Wn	REPEAT CXTSWP Wn	GOTO lit24	DISCTL	CALL lit24			
l			11	ADD Ws and lit7	ADDC Ws and lit7	SUB Ws and lit7	SUBB Ws and lit7	AND Ws and lit7	IOR Ws and lit7	ANDL Ws and lit7	SUBRR Ws and lit7	XOR Ws and lit7		MULSS/US s16	MULLSU/US s16	MULLSS/US	MULLSU/SJ MULAcc	MULLSS s16	MULLSU s16				
m	32-bit	11	00	MOVJ lit32/wj/sj literal																			
n			01	Instruction with File Register																			
o			10	LAC LAC ADD, SUB	SAC SAC SACR SRS, SJAC	MIN, SRR MAX, NORM	SFRAC, SFRAC SRS LJAC	MAC/SQRC MAC/SQRC	MPV/SQR MPV/SQR	EDAC ED													
p			11	ASRM LSRM SJM by IHS	ASRM LSRM SJM by Wb	FLM MIN MAX	FFIL FDIR FBL	DMS DIMU DIMF	DVSL DMUL DMFL	MOVJ MoveJ (extended) to Wd	MOVJ MoveJ (extended) to Wd	GOTO CALL IZ	MOVJ SWAP	BPNS BPEXT	RESET BOOTSWAP	MOV [Wb + SRS] Wnd	NOPR (32-bit)						

6.2. Instruction Set Summary Table

The complete 16-bit DSC device instruction set is summarized in [Table 6-1](#). This table contains an alphabetized listing of the instruction set. It includes instruction assembly syntax, description, size (in 24-bit words), execution time (in instruction cycles), affected Status bits and the page number where the detailed description can be found. The dsPIC33A CPU Instruction Status Flag Operations section identifies the symbols that are used in the [Table 6-1](#).

Table 6-1. Instruction Set Summary Table

Assembly Mnemonic ¹	Description	Words	Cycles	C	N	OV	Z	OA	OB	SA	SB(1)	OAB	SAB(1)
ADD	$f + W_n$ or $W_n = f + W_n$	1	1	↕	↕	↕	↕	—	—	—	—	—	—
	$W_n = W_n + \text{lit5}$	0.5	1	↕	↕	↕	↕	—	—	—	—	—	—
	$W_n = W_n + \text{lit16}$	1	1	↕	↕	↕	↕	—	—	—	—	—	—
	$W_d = W_b + W_s$	0.5/1	1	↕	↕	↕	↕	—	—	—	—	—	—
	$W_d = W_b + \text{lit7}$ (literal zero-extended)	1	1	↕	↕	↕	↕	—	—	—	—	—	—
	Add Accumulators	0.5	1	—	—	—	—	↕	↕	↑	↑	↕	↑
	16-bit Signed Add to Accumulator	1	1	—	—	—	—	↕	↕	↑	↑	↕	↑
ADDC	$f = f + W_n + (C)$ or $W_n = f + W_n + (C)$	1	1	↕	↕	↕	↓	—	—	—	—	—	—
	$W_n = W_n + \text{lit16} + (C)$	1	1	↕	↕	↕	↓	—	—	—	—	—	—
	$W_d = W_b + W_s + (C)$	0.5/1	1	↕	↕	↕	↓	—	—	—	—	—	—
	$W_d = W_b + \text{lit7} + (C)$ (literal zero-extended)	1	1	↕	↕	↕	↓	—	—	—	—	—	—
AND	$f = f .\text{AND. } W_n$ or $W_n = f .\text{AND. } W_n$	1	1	—	↕	—	↕	—	—	—	—	—	—
	$W_n = W_n .\text{AND. lit16}$	1	1	—	↕	—	↕	—	—	—	—	—	—
	$W_d = W_b .\text{AND. } W_s$	0.5/1	1	—	↕	—	↕	—	—	—	—	—	—
	$W_d = W_b .\text{AND. lit7}$ (literal zero-extended)	1	1	—	↕	—	↕	—	—	—	—	—	—
AND1	$W_d = W_b .\text{AND. lit7}$ (literal ones-extended)	1	1	—	↕	—	↕	—	—	—	—	—	—
ASR	$f = \text{Arithmetic Right Shift } f \text{ by } 1$ or $W_n = \text{Arithmetic Right Shift } f \text{ by } 1$	1	1	↕	↕	↕	—	—	—	—	—	—	—
	$W_d = \text{Arithmetic Right Shift } W_s \text{ by } 1$	0.5/1	1	↕	↕	↕	—	—	—	—	—	—	—
	$W_{nd} = \text{Arithmetic Right Shift } W_s \text{ by } W_b$	0.5/1	1	↕	↕	↕	—	—	—	—	—	—	—
	$W_{nd} = \text{Arithmetic Right Shift } W_s \text{ by lit5}$	0.5/1	1	↕	↕	↕	—	—	—	—	—	—	—

¹ Legend:

- ↕ set or cleared, '1' always set, '0' always cleared, — unchanged
 - ↓ may be cleared but never set (sticky), ↑ may be set but never cleared (sticky)
- Note:** SA and/or SB only modified if corresponding saturation bit is enabled, otherwise unchanged.

Table 6-1. Instruction Set Summary Table (continued)

Assembly Mnemonic ¹	Description	Words	Cycles	C	N	OV	Z	OA	OB	SA	SB(1)	OAB	SAB(1)
ASRM	Wnd = Arithmetic Right Shift Ws by lit5, then logically OR with next LS-word	1	2	—	↕	—	↓	—	—	—	—	—	—
	Wnd = Arithmetic Right Shift Ws by Wb, then logically OR with next LS-word	1	2	—	↕	—	↓	—	—	—	—	—	—
BCLR	Bit Clear f	1	1	—	—	—	—	—	—	—	—	—	—
	Bit Clear Ws	0.5/1	1	—	—	—	—	—	—	—	—	—	—
BFEXT	Bit Field Extract from Ws to Wb	1	1	—	—	—	—	—	—	—	—	—	—
	Bit Field Extract from f to Wb	2	2	—	—	—	—	—	—	—	—	—	—
BFINS	Bit Field Insert from Wb into Ws	1	1	—	—	—	—	—	—	—	—	—	—
	Bit Field Insert from Wb into f	2	2	—	—	—	—	—	—	—	—	—	—
	Bit Field Insert lit8 into Ws	2	2	—	—	—	—	—	—	—	—	—	—
BOOTSWP	Swap Active and Inactive address space	1	2	—	—	—	↕	—	—	—	—	—	—

¹ Legend:

- ↕ set or cleared, '1' always set, '0' always cleared, — unchanged
 - ↓ may be cleared but never set (sticky), ↑ may be set but never cleared (sticky)
- Note:** SA and/or SB only modified if corresponding saturation bit is enabled, otherwise unchanged.

Table 6-1. Instruction Set Summary Table (continued)

Assembly Mnemonic ¹	Description	Words	Cycles	C	N	OV	Z	OA	OB	SA	SB(1)	OAB	SAB(1)
BRA	Branch Unconditionally	1	1	—	—	—	—	—	—	—	—	—	—
	Computed Branch	1	2	—	—	—	—	—	—	—	—	—	—
	Branch if Carry	1	1(2/3)	—	—	—	—	—	—	—	—	—	—
	Branch if greater than or equal	1	1(2/3)	—	—	—	—	—	—	—	—	—	—
	Branch if unsigned greater than or equal	1	1(2/3)	—	—	—	—	—	—	—	—	—	—
	Branch if greater than	1	1(2/3)	—	—	—	—	—	—	—	—	—	—
	Branch if unsigned greater than	1	1(2/3)	—	—	—	—	—	—	—	—	—	—
	Branch if less than or equal	1	1(2/3)	—	—	—	—	—	—	—	—	—	—
	Branch if unsigned less than or equal	1	1(2/3)	—	—	—	—	—	—	—	—	—	—
	Branch if less than	1	1(2/3)	—	—	—	—	—	—	—	—	—	—
	Branch if unsigned less than	1	1(2/3)	—	—	—	—	—	—	—	—	—	—
	Branch if Negative	1	1(2/3)	—	—	—	—	—	—	—	—	—	—
	Branch if Not Carry	1	1(2/3)	—	—	—	—	—	—	—	—	—	—
	Branch if Not Negative	1	1(2/3)	—	—	—	—	—	—	—	—	—	—
	Branch if Not Overflow	1	1(2/3)	—	—	—	—	—	—	—	—	—	—
	Branch if Not Zero	1	1(2/3)	—	—	—	—	—	—	—	—	—	—
	Branch if accumulator A overflow	1	1(2/3)	—	—	—	—	—	—	—	—	—	—
	Branch if accumulator B overflow	1	1(2/3)	—	—	—	—	—	—	—	—	—	—
	Branch if Overflow	1	1(2/3)	—	—	—	—	—	—	—	—	—	—
	Branch if accumulator A saturated	1	1(2/3)	—	—	—	—	—	—	—	—	—	—
Branch if accumulator B saturated	1	1(2/3)	—	—	—	—	—	—	—	—	—	—	
Branch if Zero	1	1(2/3)	—	—	—	—	—	—	—	—	—	—	
BREAK	Stop user code execution	1	1	—	—	—	—	—	—	—	—	—	—

¹ Legend:

- \uparrow set or cleared, '1' always set, '0' always cleared, — unchanged
 - \downarrow may be cleared but never set (sticky), \uparrow may be set but never cleared (sticky)
- Note:** SA and/or SB only modified if corresponding saturation bit is enabled, otherwise unchanged.

Table 6-1. Instruction Set Summary Table (continued)

Assembly Mnemonic ¹	Description	Words	Cycles	C	N	OV	Z	OA	OB	SA	SB(1)	OAB	SAB(1)
BSET	Bit Set f	0.5/1	1	—	—	—	—	—	—	—	—	—	—
	Bit Set Ws	1	1	—	—	—	—	—	—	—	—	—	—
BSW	Write C or Z bit to Ws<Wb>	0.5/1	1	—	—	—	—	—	—	—	—	—	—
	Write C or Z bit to Ws<Wb>	1	1	—	—	—	—	—	—	—	—	—	—
BTG	Bit Toggle f	0.5/1	1	—	—	—	—	—	—	—	—	—	—
	Bit Toggle Ws	1	1	—	—	—	—	—	—	—	—	—	—
BTST	Bit Test f	0.5/1	1	↕	—	—	↕	—	—	—	—	—	—
	Bit Test Ws to C	1	1	↕	—	—	↕	—	—	—	—	—	—
	Bit Test Ws to Z	0.5/1	1	↕	—	—	↕	—	—	—	—	—	—
	Bit Test Ws<Wb> to C	1	1	↕	—	—	↕	—	—	—	—	—	—
	Bit Test Ws<Wb> to Z	1	1	↕	—	—	↕	—	—	—	—	—	—
BTSTS	Bit Test then Set f	0.5/1	1	↕	—	—	↕	—	—	—	—	—	—
	Bit Test Ws to C then Set	1	1	↕	—	—	↕	—	—	—	—	—	—
	Bit Test Ws to Z then Set			↕	—	—	↕	—	—	—	—	—	—
CALL	Call subroutine (label < ~ 16MB)	1	1	—	—	—	—	—	—	—	—	—	—
	Call subroutine (label > ~ 16MB)	2	2	—	—	—	—	—	—	—	—	—	—
	Call indirect subroutine at address [W11]	1	2	—	—	—	—	—	—	—	—	—	—
CLR	f = 0x0000	1	1										
	Wd = 0x0000	1	1										
	Clear Accumulator	0.5	1										
CLRWDT	Clear Watchdog Timer	0.5	1										
COM	f = f or Wd = f	1	1	—	↕	—	↕	—	—	—	—	—	—
	Wd = Ws	0.5/1	1	—	↕	—	↕	—	—	—	—	—	—
CP	Compare f with Ws	1	1	↕	↕	↕	↕	—	—	—	—	—	—
	Compare Ws with lit13 (literal zero-extended)	1	1	↕	↕	↕	↕	—	—	—	—	—	—
	Compare Wb with lit16 (literal zero-extended)	1	1	↕	↕	↕	↕	—	—	—	—	—	—
	Compare Wb with Ws	0.5/1	1	↕	↕	↕	↕	—	—	—	—	—	—

¹ Legend:

- ↕ set or cleared, '1' always set, '0' always cleared, — unchanged
 - ↓ may be cleared but never set (sticky), ↑ may be set but never cleared (sticky)
- Note:** SA and/or SB only modified if corresponding saturation bit is enabled, otherwise unchanged.

Table 6-1. Instruction Set Summary Table (continued)

Assembly Mnemonic ¹	Description	Words	Cycles	C	N	OV	Z	OA	OB	SA	SB(1)	OAB	SAB(1)
CP0	Compare f with 0x0000	1	1	1	↕	0	↕	—	—	—	—	—	—
	Compare Ws with 0x0000	1	1	↕	↕	↕	↕	—	—	—	—	—	—
CPB	Compare f with Ws, with borrow	1	1	↕	↕	↕	↓	—	—	—	—	—	—
	Compare Wb with lit13, with borrow(literal zero-extended)	1	1	↕	↕	↕	↓	—	—	—	—	—	—
	Compare Wb with lit16, with borrow(literal zero-extended)	1	1	↕	↕	↕	↓	—	—	—	—	—	—
	Compare Borrow Wb with Ws	0.5/1	1	↕	↕	↕	↓	—	—	—	—	—	—

¹ Legend:

- ↕ set or cleared, '1' always set, '0' always cleared, — unchanged
 - ↓ may be cleared but never set (sticky), ↑ may be set but never cleared (sticky)
- Note:** SA and/or SB only modified if corresponding saturation bit is enabled, otherwise unchanged.

Table 6-1. Instruction Set Summary Table (continued)

Assembly Mnemonic ¹	Description	Words	Cycles	C	N	OV	Z	OA	OB	SA	SB(1)	OAB	SAB(1)
CBRA	Floating Point Branch if Equal	1	1(2/3)	—	—	—	—	—	—	—	—	—	—
	Floating Point Branch if Not Equal	1	1(2/3)	—	—	—	—	—	—	—	—	—	—
	Floating Point Branch if Greater Than	1	1(2/3)	—	—	—	—	—	—	—	—	—	—
	Floating Point Branch if Greater Than or Equal	1	1(2/3)	—	—	—	—	—	—	—	—	—	—
	Floating Point Branch if Less Than	1	1(2/3)	—	—	—	—	—	—	—	—	—	—
	Floating Point Branch if Less Than or Equal	1	1(2/3)	—	—	—	—	—	—	—	—	—	—
	Floating Point Branch if Ordered	1	1(2/3)	—	—	—	—	—	—	—	—	—	—
	Floating Point Branch if Unordered or Not Equal	1	1(2/3)	—	—	—	—	—	—	—	—	—	—
	Floating Point Branch if Unordered or Equal	1	1(2/3)	—	—	—	—	—	—	—	—	—	—
	Floating Point Branch if Unordered or Less Than or Equal	1	1(2/3)	—	—	—	—	—	—	—	—	—	—
	Floating Point Branch if Unordered or Less Than	1	1(2/3)	—	—	—	—	—	—	—	—	—	—
	Floating Point Branch if Unordered or Greater Than or Equal	1	1(2/3)	—	—	—	—	—	—	—	—	—	—
	Floating Point Branch if Unordered or Greater Than	1	1(2/3)	—	—	—	—	—	—	—	—	—	—
	Floating Point Branch if Unordered	1	1(2/3)	—	—	—	—	—	—	—	—	—	—
CTXTSWP	Swap to CPU register context defined in lit3	0.5	2	—	—	—	—	—	—	—	—	—	—
	Swap to CPU register context defined in Wn[2:0]	1	2	—	—	—	—	—	—	—	—	—	—
DTB	Decrement Wn, then branch if not zero	1	1(2/3)	—	—	—	—	—	—	—	—	—	—

¹ Legend:

- \uparrow set or cleared, '1' always set, '0' always cleared, — unchanged
 - \downarrow may be cleared but never set (sticky), \uparrow may be set but never cleared (sticky)
- Note:** SA and/or SB only modified if corresponding saturation bit is enabled, otherwise unchanged.

Table 6-1. Instruction Set Summary Table (continued)

Assembly Mnemonic ¹	Description	Words	Cycles	C	N	OV	Z	OA	OB	SA	SB(1)	OAB	SAB(1)
DEC	f = f - 1 or Wnd = f - 1	1	1	↕	↕	↕	↕	—	—	—	—	—	—
	Wd = Ws - 1 (substitute with SUB Ws,#1,Wd)	1	1	↕	↕	↕	↕	—	—	—	—	—	—
DEC2	f = f - 2 or Wnd = f - 2	1	1	↕	↕	↕	↕	—	—	—	—	—	—
	Wd = Ws - 2 (substitute with SUB Ws,#2,Wd)	1	1	↕	↕	↕	↕	—	—	—	—	—	—
DISICTL	Disable interrupts at IPL <= lit3 Optionally save prior IPL threshold to Wd	1	1	—	—	—	—	—	—	—	—	—	—
	Disable interrupts at IPL <= Wns[2:0] Optionally save prior IPL threshold to Wd	1	1	—	—	—	—	—	—	—	—	—	—
DIVF	Interruptible Signed 16/16 or 32/16 Fractional Divide	1	1	↕	↕	↕	↕	—	—	—	—	—	—
DIVFL	Interruptible Signed 32/32 Fractional Divide	1	1	↕	↕	↕	↕	—	—	—	—	—	—
DIVS	Interruptible Signed 16/16-bit Integer Divide	1	1	↕	↕	↕	↕	—	—	—	—	—	—
	Interruptible Signed 32/16-bit Integer Divide	1	1	↕	↕	↕	↕	—	—	—	—	—	—
DIVSL	Interruptible Signed 32/32 Integer Divide	1	1	↕	↕	↕	↕	—	—	—	—	—	—
DIVU	Interruptible Unsigned 16/16-bit Integer Divide	1	1	↕	0	0	↕	—	—	—	—	—	—
	Interruptible Unsigned 32/16-bit Integer Divide	1	1	↕	0	↕	↕	—	—	—	—	—	—
DIVUL	Interruptible Unsigned 32/32 Integer Divide	1	1	↕	0	0	↕	—	—	—	—	—	—
ED	Euclidean Distance	1	2	—	—	—	—	↕	↕	↑	↑	↕	↑
EDAC	Euclidean Distance Accumulate	1	2	—	—	—	—	↕	↕	↑	↑	↕	↑
EXCH	Swap Wns with Wnd	1	2	—	—	—	—	—	—	—	—	—	—
FBCL	Find Bit Change from Left (MSb) Side	1	1	↕	—	—	—	—	—	—	—	—	—
FF1L	Find First One from Left (MSb) Side	1	1	↕	—	—	—	—	—	—	—	—	—

¹ Legend:

- ↕ set or cleared, '1' always set, '0' always cleared, — unchanged
 - ↓ may be cleared but never set (sticky), ↑ may be set but never cleared (sticky)
- Note:** SA and/or SB only modified if corresponding saturation bit is enabled, otherwise unchanged.

Table 6-1. Instruction Set Summary Table (continued)

Assembly Mnemonic ¹	Description	Words	Cycles	C	N	OV	Z	OA	OB	SA	SB(1)	OAB	SAB(1)
FF1R	Find First One from Right (LSb) Side	1	1	↕	—	—	—	—	—	—	—	—	—
FLIM	Force Data (Upper and Lower) Range Limit without Limit Excess Result	1	1	—	↕	0	↕	—	—	—	—	—	—
	Force Data (Upper and Lower) Range Limit with Limit Excess Flag (Wd = -1)	1	2	—	↕	0	↕	—	—	—	—	—	—
	Force Data (Upper and Lower) Range Limit with Limit Excess Result	1	2	—	↕	0	↕	—	—	—	—	—	—
GOTO	Go to address (address < ~ 16MB)	1	1	—	—	—	—	—	—	—	—	—	—
	Go to address (address > ~ 16MB)	2	2	—	—	—	—	—	—	—	—	—	—
	Go to indirect address at [W11]	1	2	—	—	—	—	—	—	—	—	—	—
INC	f = f + 1 or Wnd = f + 1	1	1	↕	↕	↕	↕	—	—	—	—	—	—
	Wd = Ws + 1 (substitute with ADD Ws,#1,Wd)	1	1	↕	↕	↕	↕	—	—	—	—	—	—
INC2	f = f + 2 or Wnd = f + 2	1	1	↕	↕	↕	↕	—	—	—	—	—	—
	Wd = Ws + 2 (substitute with ADD Ws,#2,Wd)	1	1	↕	↕	↕	↕	—	—	—	—	—	—
IOR	f = f .IOR. Wn or Wn = f .IOR. Wn	1	1	—	↕	—	↕	—	—	—	—	—	—
	Wn = Wn .IOR. lit16	1	1	—	↕	—	↕	—	—	—	—	—	—
	Wd = Wb .IOR. Ws	0.5/1	1	—	↕	—	↕	—	—	—	—	—	—
	Wd = Wb .IOR. lit7	1	1	—	↕	—	↕	—	—	—	—	—	—
LAC	Load Accumulator (16/32-bit), literal shift	1	1	—	—	—	—	↕	↕	↑	↑	↕	↑
LLAC	Load Lower (LS-word of) Accumulator (32-bit), literal shift	1	1	—	—	—	—	↕	↕	↑	↑	↕	↑
LUAC	Load Upper (LS-byte) of Accumulator (32-bit), literal shift	1	1	—	—	—	—	↕	↕	↑	↑	↕	↑

¹ Legend:

- ↕ set or cleared, '1' always set, '0' always cleared, — unchanged
- ↓ may be cleared but never set (sticky), ↑ may be set but never cleared (sticky)

Note: SA and/or SB only modified if corresponding saturation bit is enabled, otherwise unchanged.

Table 6-1. Instruction Set Summary Table (continued)

Assembly Mnemonic ¹	Description	Words	Cycles	C	N	OV	Z	OA	OB	SA	SB(1)	OAB	SAB(1)
LNK	Link frame pointer	1	1	—	—	—	—	—	—	—	—	—	—
	Link frame pointer (literal < 128)	0.5	1	—	—	—	—	—	—	—	—	—	—
LSR	f = Logical Right Shift f by 1 or Wd = Logical Right Shift f by 1	1	1	⇕	0	—	⇕	—	—	—	—	—	—
	Wd = Logical Right Shift Ws by 1	0.5/1	1	⇕	0	—	⇕	—	—	—	—	—	—
	Wnd = Logical Right Shift Ws by Wns	0.5/1	1	⇕	0	—	⇕	—	—	—	—	—	—
	Wnd = Logical Right Shift Ws by lit5	0.5/1	1	⇕	0	—	⇕	—	—	—	—	—	—
LSRM	Wnd = Logical Right Shift Ws by lit5, then logically OR with next LS-word	1	2	⇕	0	—	⇕	—	—	—	—	—	—
	Wnd = Logical Right Shift Ws by Wb, then logically OR with next LS-word	1	2	⇕	0	—	⇕	—	—	—	—	—	—
MAC	Multiply and Accumulate	1	1	—	—	—	—	⇕	⇕	↑	↑	⇕	↑
MAX	Force Data Maximum Range Limit	1	1	—	0	0	⇕	—	—	—	—	—	—
	Force Data Maximum Range Limit	0.5	1	—	0	0	⇕	—	—	—	—	—	—
	Force Data Maximum Range Limit with Result	1	2	—	0	0	⇕	—	—	—	—	—	—
MIN	Force Data Minimum Range Limit	1	1	—	⇕	0	⇕	—	—	—	—	—	—
	Force Data Minimum Range Limit	0.5	1	—	⇕	0	⇕	—	—	—	—	—	—
	Force Data Minimum Range Limit with Result	1	2	—	⇕	0	⇕	—	—	—	—	—	—

¹ Legend:

- ⇕ set or cleared, '1' always set, '0' always cleared, — unchanged
 - ↓ may be cleared but never set (sticky), ↑ may be set but never cleared (sticky)
- Note:** SA and/or SB only modified if corresponding saturation bit is enabled, otherwise unchanged.

Table 6-1. Instruction Set Summary Table (continued)

Assembly Mnemonic ¹	Description	Words	Cycles	C	N	OV	Z	OA	OB	SA	SB(1)	OAB	SAB(1)
MOV	Move Ws to Wd	0.5/1	1	—	—	—	—	—	—	—	—	—	—
	Move coprocessor register to Wd	0.5/1	1	—	—	—	—	—	—	—	—	—	—
	Move Ws to coprocessor register	0.5/1	1	—	—	—	—	—	—	—	—	—	—
	Move 32-bit unsigned literal to Wnd	2	2	—	—	—	—	—	—	—	—	—	—
	Move 8/16/24-bit unsigned literal to Wnd; 0 extend to 32-bits	1	1	—	—	—	—	—	—	—	—	—	—
	Move 32-bit unsigned literal to co-processor register	2	2	—	—	—	—	—	—	—	—	—	—
	Move from system stack with literal offset to Wnd using SP or FP	0.5	1	—	—	—	—	—	—	—	—	—	—
	Move from Wns to system stack with literal offset using SP or FP	0.5	1	—	—	—	—	—	—	—	—	—	—
	Move f to Wnd (Word or Long Word only) (f < ~1MB)	1	1	—	—	—	—	—	—	—	—	—	—
	Move f to Wnd (f > ~1MB)	2	2	—	—	—	—	—	—	—	—	—	—
	Move f to Wnd (Byte)	1	1	—	—	—	—	—	—	—	—	—	—
	Move Wns to f (Word or Long Word only) (f < ~1MB)	1	1	—	—	—	—	—	—	—	—	—	—
	Move Wns to f (f > ~1MB)	2	2	—	—	—	—	—	—	—	—	—	—
	Move Wns to f (Byte)	1	1	—	—	—	—	—	—	—	—	—	—
	Move [Wns+Slit12/13/14] to Wnd (Slitxx size varies with data width)	1	1	—	—	—	—	—	—	—	—	—	—
	Move [Wns+Slit14] to Fd	1	1	—	—	—	—	—	—	—	—	—	—
	Move Wns to [Wnd+Slit12/13/14] (Slitxx size varies with data width)	1	1	—	—	—	—	—	—	—	—	—	—
Move Fs to [Wnd+Slit14]	1	1	—	—	—	—	—	—	—	—	—	—	

¹ Legend:

- \updownarrow set or cleared, '1' always set, '0' always cleared, — unchanged
 - \downarrow may be cleared but never set (sticky), \uparrow may be set but never cleared (sticky)
- Note:** SA and/or SB only modified if corresponding saturation bit is enabled, otherwise unchanged.

Table 6-1. Instruction Set Summary Table (continued)

Assembly Mnemonic ¹	Description	Words	Cycles	C	N	OV	Z	OA	OB	SA	SB(1)	OAB	SAB(1)
MOVIF	If SR.Z = 1 Move Wb to Wd Else Move Wns to Wd	1	1	—	—	—	—	—	—	—	—	—	—
MOVR	Move Ws to Wd with destination Bit Reversed addressing	1	1	—	—	—	—	—	—	—	—	—	—
MOVS.l	Move signed extended 16-bit literal to Wd	1	1	—	—	—	—	—	—	—	—	—	—
MOVS.w	Move 16-bit literal to Wd; sign extend to 32-bits if register direct mode.	1	1	—	—	—	—	—	—	—	—	—	—
MOVS.b	Move 8-bit literal to Wd; no extension.	1	1	—	—	—	—	—	—	—	—	—	—
MPY	Multiply Wm by Wn to Accumulator	1	1	—	—	—	—	⇕	⇕	↑	↑	⇕	↑
MPYN	-(Multiply Wm by Wn) to Accumulator	1	1	—	—	—	—	⇕	⇕	↑	↑	⇕	↑
MSC	Multiply and Subtract from Accumulator	1	1	—	—	—	—	⇕	⇕	↑	↑	⇕	↑
MUL	$W2 = f * Wn$	1	1	—	—	—	—	—	—	—	—	—	—
MULFSS	Fractional: $Acc(A \text{ or } B) = signed(Wb) * signed(Ws)$	1	1	—	—	—	—	—	—	—	—	—	—
MULFSU	Fractional: $Acc(A \text{ or } B) = signed(Wb) * unsigned(Ws)$	1	1	—	—	—	—	—	—	—	—	—	—
MULFUS	Fractional: $Acc(A \text{ or } B) = unsigned(Wb) * signed(Ws)$	1	1	—	—	—	—	—	—	—	—	—	—
MULFUU	Fractional: $Acc(A \text{ or } B) = unsigned(Wb) * unsigned(Ws)$	1	1	—	—	—	—	—	—	—	—	—	—
MULISS	Integer: $Acc(A \text{ or } B) = signed(Wb) * signed(Ws)$	1	1	—	—	—	—	—	—	—	—	—	—
	Integer: $Acc(A \text{ or } B) = signed(Wb) * signed(slit8)$	1	1	—	—	—	—	—	—	—	—	—	—
MULISU	Integer: $Acc(A \text{ or } B) = signed(Wb) * unsigned(Ws)$	1	1	—	—	—	—	—	—	—	—	—	—
	Integer: $Acc(A \text{ or } B) = signed(Wb) * unsigned(lit8)$	1	1	—	—	—	—	—	—	—	—	—	—

¹ Legend:

- ⇕ set or cleared, '1' always set, '0' always cleared, — unchanged
 - ⇓ may be cleared but never set (sticky), ⇑ may be set but never cleared (sticky)
- Note:** SA and/or SB only modified if corresponding saturation bit is enabled, otherwise unchanged.

Table 6-1. Instruction Set Summary Table (continued)

Assembly Mnemonic ¹	Description	Words	Cycles	C	N	OV	Z	OA	OB	SA	SB(1)	OAB	SAB(1)
MULIUS	Integer: Acc(A or B) = unsigned(Wb) * signed(Ws)	1	1	—	—	—	—	—	—	—	—	—	—
	Integer: Acc(A or B) = unsigned(Wb) * signed(slit8)	1	1	—	—	—	—	—	—	—	—	—	—
MULIUU	Integer: Acc(A or B) = unsigned(Wb) * unsigned(Ws)	1	1	—	—	—	—	—	—	—	—	—	—
	Integer: Acc(A or B) = unsigned(Wb) * unsigned(lit8)	1	1	—	—	—	—	—	—	—	—	—	—
MULSS	{Wd}=signed(Wb) * signed(Ws)	0.5/1	1	—	—	—	—	—	—	—	—	—	—
	{Wd}=signed(Wb) * signed(slit8)	1	1	—	—	—	—	—	—	—	—	—	—
MULSU	{Wd}=signed(Wb) * unsigned(Ws)	0.5/1	1	—	—	—	—	—	—	—	—	—	—
	{Wd}=signed(Wb) * unsigned(lit8)	1	1	—	—	—	—	—	—	—	—	—	—
MULUS	{Wd}=unsigned(Wb) * signed(Ws)	0.5/1	1	—	—	—	—	—	—	—	—	—	—
	{Wd}=unsigned(Wb) * signed(slit8)	1	1	—	—	—	—	—	—	—	—	—	—
MULUU	{Wd}=unsigned(Wb) * unsigned(Ws)	0.5/1	1	—	—	—	—	—	—	—	—	—	—
	{Wd}=unsigned(Wb) * unsigned(lit8)	1	1	—	—	—	—	—	—	—	—	—	—
NEG	Negate Accumulator	0.5	1	—	—	—	—	↕	↕	↑	↑	↕	↑
	$f = \bar{f} + 1$ or $Wd = \bar{Wd} + 1$	1	1	↕	0	↕	↕	—	—	—	—	—	—
	$Wd = \bar{Wd} + 1$	0.5/1	1	↕	0	↕	↕	—	—	—	—	—	—
NEOP	None executable NOP (16-bit instruction pad)	0.5	0	—	—	—	—	—	—	—	—	—	—
NOP	No Operation	1	1	—	—	—	—	—	—	—	—	—	—
	No Operation	1	1	—	—	—	—	—	—	—	—	—	—
NORM	Normalize Accumulator	1	1	—	↕	—	↕	0	0	—	—	—	—
POP	Pop f from top of stack (TOS)	1	1	—	—	—	—	—	—	—	—	—	—
	Pop Wnd Register from system stack.	0.5	1	—	—	—	—	—	—	—	—	—	—
	Pop Fd Register from system stack.	0.5	1	—	—	—	—	—	—	—	—	—	—

¹ Legend:

- ↕ set or cleared, '1' always set, '0' always cleared, — unchanged
 - ↓ may be cleared but never set (sticky), ↑ may be set but never cleared (sticky)
- Note:** SA and/or SB only modified if corresponding saturation bit is enabled, otherwise unchanged.

Table 6-1. Instruction Set Summary Table (continued)

Assembly Mnemonic ¹	Description	Words	Cycles	C	N	OV	Z	OA	OB	SA	SB(1)	OAB	SAB(1)
PUSH	Push f to top of stack (TOS)	1	1	—	—	—	—	—	—	—	—	—	—
	Push Wns Register to system stack	0.5	1	—	—	—	—	—	—	—	—	—	—
	Push Fs Register to system stack	0.5	1	—	—	—	—	—	—	—	—	—	—
PWRSVAV	Go into standby mode	0.5	2	—	—	—	—	—	—	—	—	—	—
RCALL	Relative Call	1	1	—	—	—	—	—	—	—	—	—	—
	Computed Call	1	2	—	—	—	—	—	—	—	—	—	—
REPEAT	Repeat Next Instruction lit15+1 times	1	1	—	—	—	—	—	—	—	—	—	—
	Repeat Next Instruction lit5+1 times	0.5	1	—	—	—	—	—	—	—	—	—	—
	Repeat Next Instruction (Wn)+1 times	1	1	—	—	—	—	—	—	—	—	—	—
RESET	Software device RESET	1	1	—	—	—	—	—	—	—	—	—	—
RETFIE	Return from interrupt enable	0.5	4	↕	↕	↕	↕	—	—	—	—	—	—
RETLW	Return from Subroutine with literal in Wn	1	3	—	—	—	—	—	—	—	—	—	—
RETURN	Return from Subroutine	0.5	3	—	—	—	—	—	—	—	—	—	—
RLC	f = Rotate Left through Carry f or Wd = Rotate Left through Carry f	1	1	↕	↕	—	↕	—	—	—	—	—	—
	Wd = Rotate Left through Carry Ws	0.5/1	1	↕	↕	—	↕	—	—	—	—	—	—
RLNC	f = Rotate Left (No Carry) f or Wd = Rotate Left (No Carry) f	1	1	—	↕	—	↕	—	—	—	—	—	—
	Wd = Rotate Left (No Carry) Ws	0.5/1	1	—	↕	—	↕	—	—	—	—	—	—
RRC	f = Rotate Right through Carry f or Wd = Rotate Right through Carry f	1	1	↕	↕	—	↕	—	—	—	—	—	—
	Wd = Rotate Right through Carry Ws	0.5/1	1	↕	↕	—	↕	—	—	—	—	—	—

¹ Legend:

- ↕ set or cleared, '1' always set, '0' always cleared, — unchanged
 - ↓ may be cleared but never set (sticky), ↑ may be set but never cleared (sticky)
- Note:** SA and/or SB only modified if corresponding saturation bit is enabled, otherwise unchanged.

Table 6-1. Instruction Set Summary Table (continued)

Assembly Mnemonic ¹	Description	Words	Cycles	C	N	OV	Z	OA	OB	SA	SB(1)	OAB	SAB(1)
RRNC	f = Rotate Right (No Carry) f or Wd = Rotate Right (No Carry) f	1	1	—	↕	—	↕	—	—	—	—	—	—
	Wd = Rotate Right (No Carry) Ws	0.5/1	1	—	↕	—	↕	—	—	—	—	—	—
SAC	Store Accumulator (16/32-bit)	1	1	—	—	—	—	—	—	—	—	—	—
SACR	Store Rounded Accumulator (16/32-bit), literal shift	1	1	—	—	—	—	—	—	—	—	—	—
	Store Rounded Accumulator (16/32-bit), Wb shift	1	1	—	—	—	—	—	—	—	—	—	—
SLAC	Store Lower (LS-Word of) Accumulator (32-bit), literal shift	1	1	—	—	—	—	—	—	—	—	—	—
SUAC	Store sign extended Upper (MS-Byte of) Accumulator (32-bit), literal shift	1	1	—	—	—	—	—	—	—	—	—	—
SE	Wd = sign-extended Ws	0.5/1	1	↕	↕	—	↕	—	—	—	—	—	—
SETM	f = 0xFFFF	1	1	—	—	—	—	—	—	—	—	—	—
	Wd = 0xFFFF (substitute with MOVS #0xFFFF, Wd)	1	1	—	—	—	—	—	—	—	—	—	—
SFTAC	Arithmetic Shift Accumulator by (Wn)	1	1	—	—	—	—	↕	↕	↑	↑	↕	↑
	Arithmetic Shift Accumulator by Slit7	1	1	—	—	—	—	↕	↕	↑	↑	↕	↑
SL	f = Left Shift f by 1 or Wd = Left Shift f by 1	1	1	↕	↕	—	↕	—	—	—	—	—	—
	Wd = Left Shift Ws by 1	0.5/1	1	↕	↕	—	↕	—	—	—	—	—	—
	Wnd = Left Shift Wb by Wns	0.5/1	1	↕	↕	—	↕	—	—	—	—	—	—
	Wnd = Left Shift Ws by lit5	0.5/1	1	↕	↕	—	↕	—	—	—	—	—	—

¹ Legend:

- ↕ set or cleared, '1' always set, '0' always cleared, — unchanged
 - ↓ may be cleared but never set (sticky), ↑ may be set but never cleared (sticky)
- Note:** SA and/or SB only modified if corresponding saturation bit is enabled, otherwise unchanged.

Table 6-1. Instruction Set Summary Table (continued)

Assembly Mnemonic ¹	Description	Words	Cycles	C	N	OV	Z	OA	OB	SA	SB(1)	OAB	SAB(1)
SLM	Wnd = Left Shift Wb by lit5, then logically OR with next MS-word	1	2	—	—	—	↓	—	—	—	—	—	—
	Wnd = Left Shift Wb by Wb, then logically OR with next MS-word	1	2	—	—	—	↓	—	—	—	—	—	—
SQR	Square to Accumulator	1	1	—	—	—	—	↕	↕	↑	↑	↕	↑
SQRAC	Square and Accumulate	1	1	—	—	—	—	↕	↕	↑	↑	↕	↑
SQRN	Negated Square to Accumulator	1	1	—	—	—	—	↕	↕	↑	↑	↕	↑
SQRSC	Square and Subtract from Accumulator	1	1	—	—	—	—	↕	↕	↑	↑	↕	↑
SSTEP	Single step	1	5	—	—	—	—	—	—	—	—	—	—
SUB	Subtract Accumulators	0.5	1	↕	↕	↕	↕	—	—	—	—	—	—
	$f = f - Wn$ or $Wn = f - Wn$	1	1	↕	↕	↕	↕	—	—	—	—	—	—
	$Wn = Wn - lit5$	0.5	1	↕	↕	↕	↕	—	—	—	—	—	—
	$Wn = Wn - lit16$	1	1	↕	↕	↕	↕	—	—	—	—	—	—
	$Wd = Wb - Ws$	0.5/1	1	↕	↕	↕	↕	—	—	—	—	—	—
	$Wd = Ws - lit7$ (literal zero-extended)	1	1	↕	↕	↕	↕	—	—	—	—	—	—
16-bit Signed Subtract from Accumulator	1	1	↕	↕	↕	↕	—	—	—	—	—	—	
SUBB	$f = f - Wn - (C)$ or $Wn = f - Wn - (C)$	1	1	↕	↕	↕	↓	—	—	—	—	—	—
	$Wn = Wn - lit16 - (C)$	1	1	↕	↕	↕	↓	—	—	—	—	—	—
	$Wd = Wb - Ws - (C)$	0.5/1	1	↕	↕	↕	↓	—	—	—	—	—	—
	$Wd = Ws - lit7 - (C)$ (literal zero-extended)	1	1	↕	↕	↕	↓	—	—	—	—	—	—
SUBR	$f = Wn - f$ or $Wn = Wn - f$	1	1	↕	↕	↕	↕	—	—	—	—	—	—
	$Wd = Ws - Wb$	0.5/1	1	↕	↕	↕	↕	—	—	—	—	—	—
	$Wd = lit7 - Ws$ (literal zero-extended)	0.5/1	1	↕	↕	↕	↕	—	—	—	—	—	—

¹ Legend:

- ↕ set or cleared, '1' always set, '0' always cleared, — unchanged
 - ↓ may be cleared but never set (sticky), ↑ may be set but never cleared (sticky)
- Note:** SA and/or SB only modified if corresponding saturation bit is enabled, otherwise unchanged.

Table 6-1. Instruction Set Summary Table (continued)

Assembly Mnemonic ¹	Description	Words	Cycles	C	N	OV	Z	OA	OB	SA	SB(1)	OAB	SAB(1)
SUBBR	$f = Wn - f - (C)$ or $Wn = Wn - f - (C)$	1	1	↕	↕	↕	↓	—	—	—	—	—	—
	$Wd = Ws - Wb - (C)$	0.5/1	1	↕	↕	↕	↓	—	—	—	—	—	—
	$Wd = \text{lit7} - Ws - (C)$ (literal zero-extended)	1	1	↕	↕	↕	↓	—	—	—	—	—	—
SWAP	$Wn = \text{Word or byte swap } Wn$	1	1	—	—	—	—	—	—	—	—	—	—
TST	Test f	1	1	—	↕	—	↕	—	—	—	—	—	—
	Test f and move f to Wnd	1	1	—	↕	—	↕	—	—	—	—	—	—
UFEX	Execute op(s) in FEX2:FEX in Mission	1	5	—	—	—	—	—	—	—	—	—	—
ULNK	Unlink frame pointer	0.5	1	—	—	—	—	—	—	—	—	—	—
URUN	Switch from debug PC to user PC	1	3	—	—	—	—	—	—	—	—	—	—
XOR	$f = f .XOR. Wn$ or $Wn = f .XOR. Wn$	1	1	—	↕	—	↕	—	—	—	—	—	—
	$Wn = Wn .XOR. \text{lit16}$	1	1	—	↕	—	↕	—	—	—	—	—	—
	$Wd = Wb .XOR. Ws$	0.5/1	1	—	↕	—	↕	—	—	—	—	—	—
	$Wd = Wb .XOR. \text{lit7}$ (literal zero-extended)	1	1	—	↕	—	↕	—	—	—	—	—	—
ZE	$Wd = \text{Zero-extend } Ws$	0.5/1	1	1	0	—	↕	—	—	—	—	—	—

¹ Legend:

- ↕ set or cleared, '1' always set, '0' always cleared, — unchanged
 - ↓ may be cleared but never set (sticky), ↑ may be set but never cleared (sticky)
- Note:** SA and/or SB only modified if corresponding saturation bit is enabled, otherwise unchanged.

Table 6-2. FPU Instruction Set Summary

Instruction ² : Description	Cycle Count	FPU Status Register (FSR)														
		FSR[28:24]					FSR[19:16]				FSR[6:0]					
		SUB	INF	FN	FZ	FNA N	GT	LT	EQ	UN	SUBO	HUGI	INX	UDF	OVF	DIV0
Move instructions																
MOV: Move (Wns+offset) to Fd	1	—	—	—	—	—	—	—	—	—	—	—	—	—	—	—
MOV: Move Fs to (Wnd+offset)	1	—	—	—	—	—	—	—	—	—	—	—	—	—	—	—
MOV: Move (Ws) to Fd or FSR or FCR or FEAR	1	—	—	—	—	—	—	—	—	—	—	—	—	—	—	—
MOV: Move Fs or FSR or FCR or FEAR to (Wd)	1	—	—	—	—	—	—	—	—	—	—	—	—	—	—	—
MOV: Move 32-bit literal value into Fd or FSR or FCR	1	—	—	—	—	—	—	—	—	—	—	—	—	—	—	—
PUSH: Push Fs or FSR or FCR or FSRH to system stack	1	—	—	—	—	—	—	—	—	—	—	—	—	—	—	—
POP: Pop Fd or FSR or FCR from system stack	1	—	—	—	—	—	—	—	—	—	—	—	—	—	—	—
MOV{s, .d}: Move Fs to Fd	1	—	—	—	—	—	—	—	—	—	—	—	—	—	—	—
MOVC{s, .d}: Load constant value into Fd	1	—	—	—	—	—	—	—	—	—	—	—	—	—	—	—
Status Bit Set/Clear/Update Instructions																
AND: Clear bit(s) in active FP special reg, bits specified by literal value.	1	—	—	—	—	—	—	—	—	—	↓	↓	↓	↓	↓	↓
IOR: Set bit(s) in active FP special reg, bits specified by literal value.	1	—	—	—	—	—	—	—	—	—	↑	↑	↑	↑	↑	↑
TST{s, .d}: Test (inspect) Fs and update FSR accordingly.	1	↕	↕	↕	↕	↕	—	—	—	—	—	—	—	—	—	—
Conversion Instructions																
LI2F{s, .d}: Convert 32-bit Integer Fs to FP in Fd	1	—	—	—	—	—	—	—	—	—	0	0	↕	0	0	0
DI2F{s, .d}: Convert 64-bit Integer Fs to FP in Fd	1	—	—	—	—	—	—	—	—	—	0	0	↕	0	0	0
F2LI{s, .d}: Convert FP Fs to 32-bit Integer in Fd	1 for SP 2 for DP	—	—	—	—	—	—	—	—	—	↕	↕	↕	0	0	0
F2DI{s, .d}: Convert FP Fs to 64-bit Integer in Fd	1 for SP 2 for DP	—	—	—	—	—	—	—	—	—	↕	↕	↕	0	0	0
Comparison Instructions																
CPS{s, .d}: FP Compare (Fb - Fs) with signaling exceptions	1	—	—	—	—	—	↕	↕	↕	↕	↕	0	0	0	0	0
CPQ{s, .d}: FP Compare (Fb - Fs) with quiet signaling exceptions	1	—	—	—	—	—	↕	↕	↕	↕	↕	0	0	0	0	0
FLIM{s, .d}: Clamp Fd to limits specified by Fb and Fs	1	—	—	—	—	—	—	—	—	—	↕	0	0	0	0	0

² Legend:

- ↕ set or cleared, '1' always set, '0' always cleared, — unchanged
 - ↓ may be cleared but never set (sticky), ↑ may be set but never cleared (sticky)
- Note:** SA and/or SB only modified if corresponding saturation bit is enabled, otherwise unchanged.

Table 6-2. FPU Instruction Set Summary (continued)

Instruction ² : Description	Cycle Count	FPU Status Register (FSR)															
		FSR[28:24]					FSR[19:16]				FSR[6:0]						
		SUB	INF	FN	FZ	FNA N	GT	LT	EQ	UN	SUBO	HUGI	INX	UDF	OVF	DIV0	INVAL
MAX{.s, .d}: Maximum of Fb or Fs moved to Fd: IEEE 754-2019 maximumNumber(x,y)	1	—	—	—	—	—	—	—	—	—	⇕	0	0	0	0	0	⇕
MAXNUM{.s, .d}: Maximum of Fb or Fs moved to Fd: IEEE 754-2019 maximum(x,y)	1	—	—	—	—	—	—	—	—	—	⇕	0	0	0	0	0	⇕
MIN{.s, .d}: Minimum of Fb or Fs moved to Fd: IEEE 754-2019 minimumNumber(x,y)	1	—	—	—	—	—	—	—	—	—	⇕	0	0	0	0	0	⇕
MINNUM{.s, .d}: Minimum of Fb or Fs moved to Fd: IEEE 754-2019 minimum(x,y)	1	—	—	—	—	—	—	—	—	—	⇕	0	0	0	0	0	⇕
Math Instructions																	
ADD{.s, .d}: Add: Fb + Fs,	2	—	—	—	—	—	—	—	—	—	⇕	0	⇕	⇕	⇕	0	⇕
SUB{.s, .d}: Subtract: Fb - Fs,	2	—	—	—	—	—	—	—	—	—	⇕	0	⇕	⇕	⇕	0	⇕
NEG{.s, .d}: Negate: -1 x Fs,	1	—	—	—	—	—	—	—	—	—	⇕	—	—	—	—	—	—
ABS{.s, .d}: Absolute value of Fs,	1	—	—	—	—	—	—	—	—	—	⇕	—	—	—	—	—	—
MUL{.s, .d}: Multiply: Fb x Fs	3	—	—	—	—	—	—	—	—	—	⇕	0	⇕	⇕	⇕	0	⇕
MAC{.s, .d}: Multiply and Accumulate: Fd = Fd + Fb x Fs	3 for SP 4 for DP	—	—	—	—	—	—	—	—	—	⇕	0	⇕	⇕	⇕	0	⇕
DIV{.s, .d}: Divide: Fb ÷ Fs,	11 for SP 32 for DP	—	—	—	—	—	—	—	—	—	⇕	0	⇕	⇕	⇕	⇕	⇕
SQRT{.s, .d}: Square Root of Fs,	10 for SP 13 for DP	—	—	—	—	—	—	—	—	—	⇕	0	⇕	0	0	0	⇕
SIN{.s}: Calculate Sine of Fs (radians),	4	—	—	—	—	—	—	—	—	—	⇕	0	⇕	⇕	0	0	⇕
COS{.s}: Calculate Cosine of Fs (radians), result in Fd	4	—	—	—	—	—	—	—	—	—	⇕	0	⇕	⇕	0	0	⇕
Branch Instructions																	
FBRA cc: PC branch based on FPU compare status bits.	1 for backward branch (2 or 3) for forward branch	—	—	—	—	—	—	—	—	—	—	—	—	—	—	—	—

² Legend:

- ⇕ set or cleared, '1' always set, '0' always cleared, — unchanged
 - ↓ may be cleared but never set (sticky), ↑ may be set but never cleared (sticky)
- Note:** SA and/or SB only modified if corresponding saturation bit is enabled, otherwise unchanged.

7. Revision History

The revision history describes the changes that were implemented in the document. The changes are listed by revision, starting with the most current publication.

Revision	Date	Description
C	May 2025	The following is the summary of changes in the revision C of the document: <ul style="list-style-type: none">• The document has been split into two distinct documents, one for dsPIC33A and one for PIC32A, to provide more focused and accessible information for each product line.
B	February 2025	The following is the summary of changes in the revision B of the document: <ul style="list-style-type: none">• Added example code for instructions in the Instruction Descriptions section• Updated Figure 6-1• Updated Table 6-1 and Table 6-2
A	October 2023	This is the initial release of this document.

Microchip Information

Trademarks

The “Microchip” name and logo, the “M” logo, and other names, logos, and brands are registered and unregistered trademarks of Microchip Technology Incorporated or its affiliates and/or subsidiaries in the United States and/or other countries (“Microchip Trademarks”). Information regarding Microchip Trademarks can be found at <https://www.microchip.com/en-us/about/legal-information/microchip-trademarks>.

ISBN: 979-8-3371-1252-7

Legal Notice

This publication and the information herein may be used only with Microchip products, including to design, test, and integrate Microchip products with your application. Use of this information in any other manner violates these terms. Information regarding device applications is provided only for your convenience and may be superseded by updates. It is your responsibility to ensure that your application meets with your specifications. Contact your local Microchip sales office for additional support or, obtain additional support at www.microchip.com/en-us/support/design-help/client-support-services.

THIS INFORMATION IS PROVIDED BY MICROCHIP “AS IS”. MICROCHIP MAKES NO REPRESENTATIONS OR WARRANTIES OF ANY KIND WHETHER EXPRESS OR IMPLIED, WRITTEN OR ORAL, STATUTORY OR OTHERWISE, RELATED TO THE INFORMATION INCLUDING BUT NOT LIMITED TO ANY IMPLIED WARRANTIES OF NON-INFRINGEMENT, MERCHANTABILITY, AND FITNESS FOR A PARTICULAR PURPOSE, OR WARRANTIES RELATED TO ITS CONDITION, QUALITY, OR PERFORMANCE.

IN NO EVENT WILL MICROCHIP BE LIABLE FOR ANY INDIRECT, SPECIAL, PUNITIVE, INCIDENTAL, OR CONSEQUENTIAL LOSS, DAMAGE, COST, OR EXPENSE OF ANY KIND WHATSOEVER RELATED TO THE INFORMATION OR ITS USE, HOWEVER CAUSED, EVEN IF MICROCHIP HAS BEEN ADVISED OF THE POSSIBILITY OR THE DAMAGES ARE FORESEEABLE. TO THE FULLEST EXTENT ALLOWED BY LAW, MICROCHIP’S TOTAL LIABILITY ON ALL CLAIMS IN ANY WAY RELATED TO THE INFORMATION OR ITS USE WILL NOT EXCEED THE AMOUNT OF FEES, IF ANY, THAT YOU HAVE PAID DIRECTLY TO MICROCHIP FOR THE INFORMATION.

Use of Microchip devices in life support and/or safety applications is entirely at the buyer’s risk, and the buyer agrees to defend, indemnify and hold harmless Microchip from any and all damages, claims, suits, or expenses resulting from such use. No licenses are conveyed, implicitly or otherwise, under any Microchip intellectual property rights unless otherwise stated.

Microchip Devices Code Protection Feature

Note the following details of the code protection feature on Microchip products:

- Microchip products meet the specifications contained in their particular Microchip Data Sheet.
- Microchip believes that its family of products is secure when used in the intended manner, within operating specifications, and under normal conditions.
- Microchip values and aggressively protects its intellectual property rights. Attempts to breach the code protection features of Microchip products are strictly prohibited and may violate the Digital Millennium Copyright Act.
- Neither Microchip nor any other semiconductor manufacturer can guarantee the security of its code. Code protection does not mean that we are guaranteeing the product is “unbreakable”. Code protection is constantly evolving. Microchip is committed to continuously improving the code protection features of our products.